

Search for a Heavy Photon

Bogdan Wojtsekhowski, Jefferson Lab

- Motivation
 - Possible new forces
 - Dark matter observations/indications
 - A theory of DM (one of them)
 - Heavy photon
- Axion-like/Heavy photon searches
- Experiments under preparation
- Proposal for the storage ring VEPP-3

Where is new physics

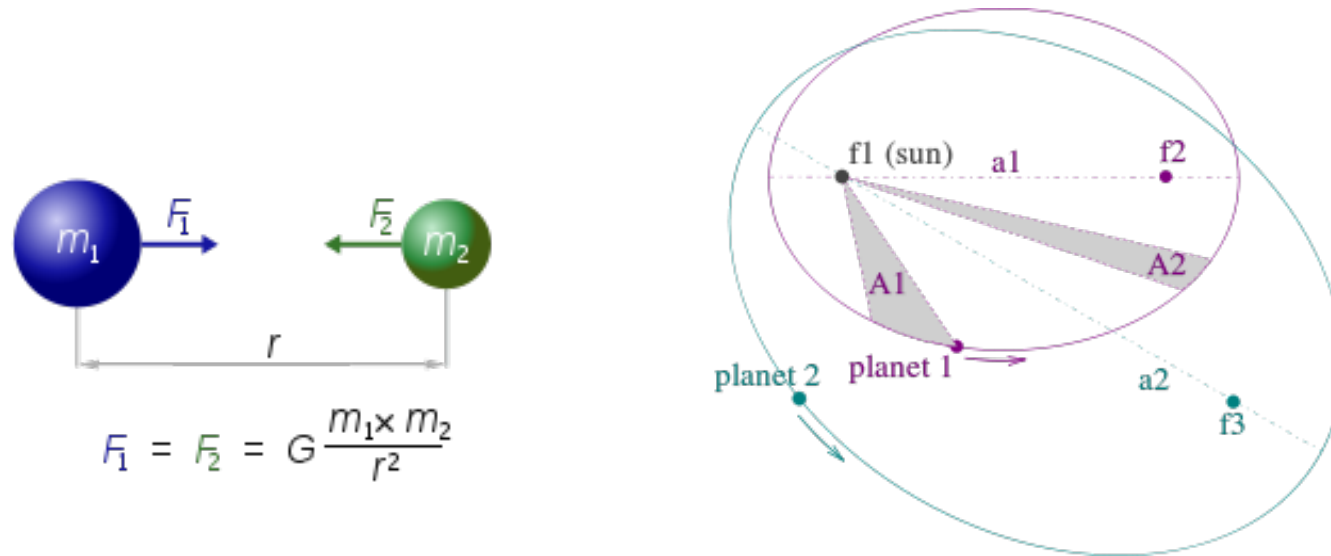

In the middle of the 18th century:

Clairaut suggested that the strength of gravity was proportional not to $\frac{1}{r^2}$, but the more complicated

$$\frac{1}{r^2} + \frac{c}{r^4}$$

for some constant c . Over large distances, the c/r^4 term would effectively disappear, accounting for the utility of the inverse square law over large distances. He then began

Where is new physics



H. Cavendish

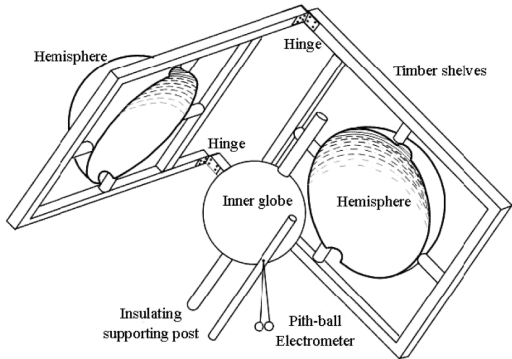
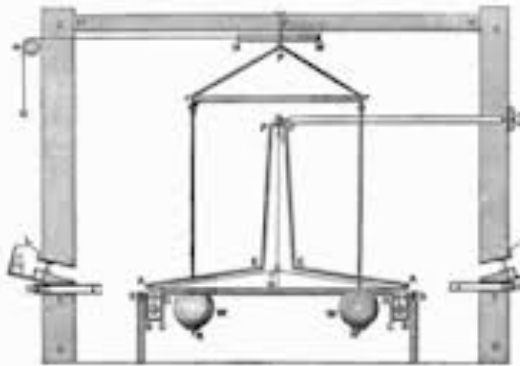

Table I. Results of various tests of Coulomb's law and tests for a nonzero photon rest mass.

	Coulomb's Law violation of form r^{2+q}	$\mu^2 = \left(\frac{m_0 c}{h}\right)^2$	Photon rest mass m_0
Cavendish (1773)	2×10^{-2}		
Coulomb (1785)	4×10^{-2}		
Maxwell (1873)	4.9×10^{-5}		
Plimpton and Lawton (1936)	2.0×10^{-9}	$1.0 \times 10^{-12} \text{ cm}^{-2}$	$\leq 3.4 \times 10^{-44} \text{ g}$
Cochran and Franken (1967)	9.2×10^{-12}	$7.3 \times 10^{-15} \text{ cm}^{-2}$	$\leq 3 \times 10^{-45} \text{ g}$
Bartlett, Goldhagen, Phillips (1970)	1.3×10^{-13}	$1 \times 10^{-16} \text{ cm}^{-2}$	$\leq 3 \times 10^{-46} \text{ g}$
Williams, Faller, Hill	$(2.7 \pm 3.1) \times 10^{-16}$	$(1.04 \pm 1.2) \times 10^{-19} \text{ cm}^{-2}$	$\leq 1.6 \times 10^{-47} \text{ g}$
Schroedinger (1943)	} Test of Ampere's Law from Geo- magnetic Data	$3 \times 10^{-19} \text{ cm}^{-2}$	$\sim 2 \times 10^{-47} \text{ g}$
Gintsburg (1963)		$5 \times 10^{-20} \text{ cm}^{-2}$	$\leq 8 \times 10^{-48} \text{ g}$
Nieto and Goldhaber (1968)		$1.3 \times 10^{-20} \text{ cm}^{-2}$	$\leq 4 \times 10^{-48} \text{ g}$
Feinberg (1969) ^a		Dispersion of light	$8 \times 10^{-14} \text{ cm}^{-2}$

SM tests, constraints on new physics (per PDG)

column denoted Pull gives the standard deviations for the principal fit with M_H free, while the column denoted Dev. (Deviation) is for $M_H = 124.5$ GeV [215] fixed.

Quantity	Value	Standard Model	Pull	Dev.
m_t [GeV]	173.4 ± 1.0	173.5 ± 1.0	-0.1	-0.3
M_W [GeV]	80.420 ± 0.031	80.381 ± 0.014	1.2	1.6
	80.376 ± 0.033		-0.2	0.2
$g_V^{\nu e}$	-0.040 ± 0.015	-0.0398 ± 0.0003	0.0	0.0
$g_A^{\nu e}$	-0.507 ± 0.014	-0.5064 ± 0.0001	0.0	0.0
$Q_W(e)$	-0.0403 ± 0.0053	-0.0474 ± 0.0005	1.3	1.3
$Q_W(\text{Cs})$	-73.20 ± 0.35	-73.23 ± 0.02	0.1	0.1
$Q_W(\text{Tl})$	-116.4 ± 3.6	-116.88 ± 0.03	0.1	0.1
τ_τ [fs]	291.13 ± 0.43	290.75 ± 2.51	0.1	0.1
$\frac{1}{2}(g_\mu - 2 - \frac{\alpha}{\pi})$	$(4511.07 \pm 0.77) \times 10^{-9}$	$(4508.70 \pm 0.09) \times 10^{-9}$	3.0	3.0

SM tests, constraints on new physics (per PDG)

$g - 2$ for the muon

Largest contribution : $a_\mu = \frac{\alpha}{2\pi} \approx \frac{1}{800}$

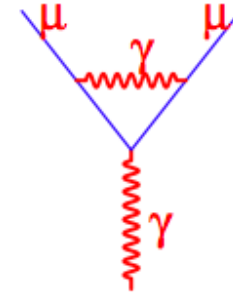

Other standard model contributions :

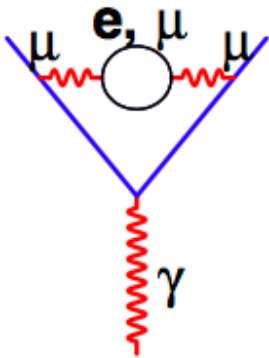

QED

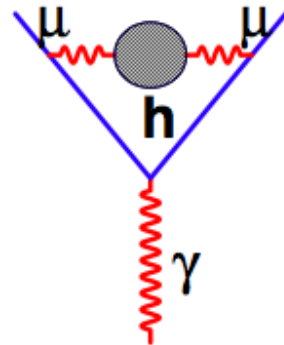

hadronic

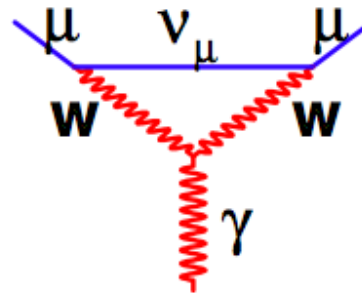

weak

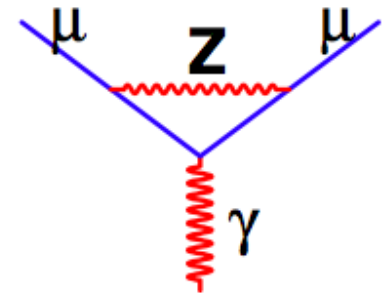

from STORY05, Y. Semertzidis

The motivation is the nature of dark matter

1985ApJ...295..422C

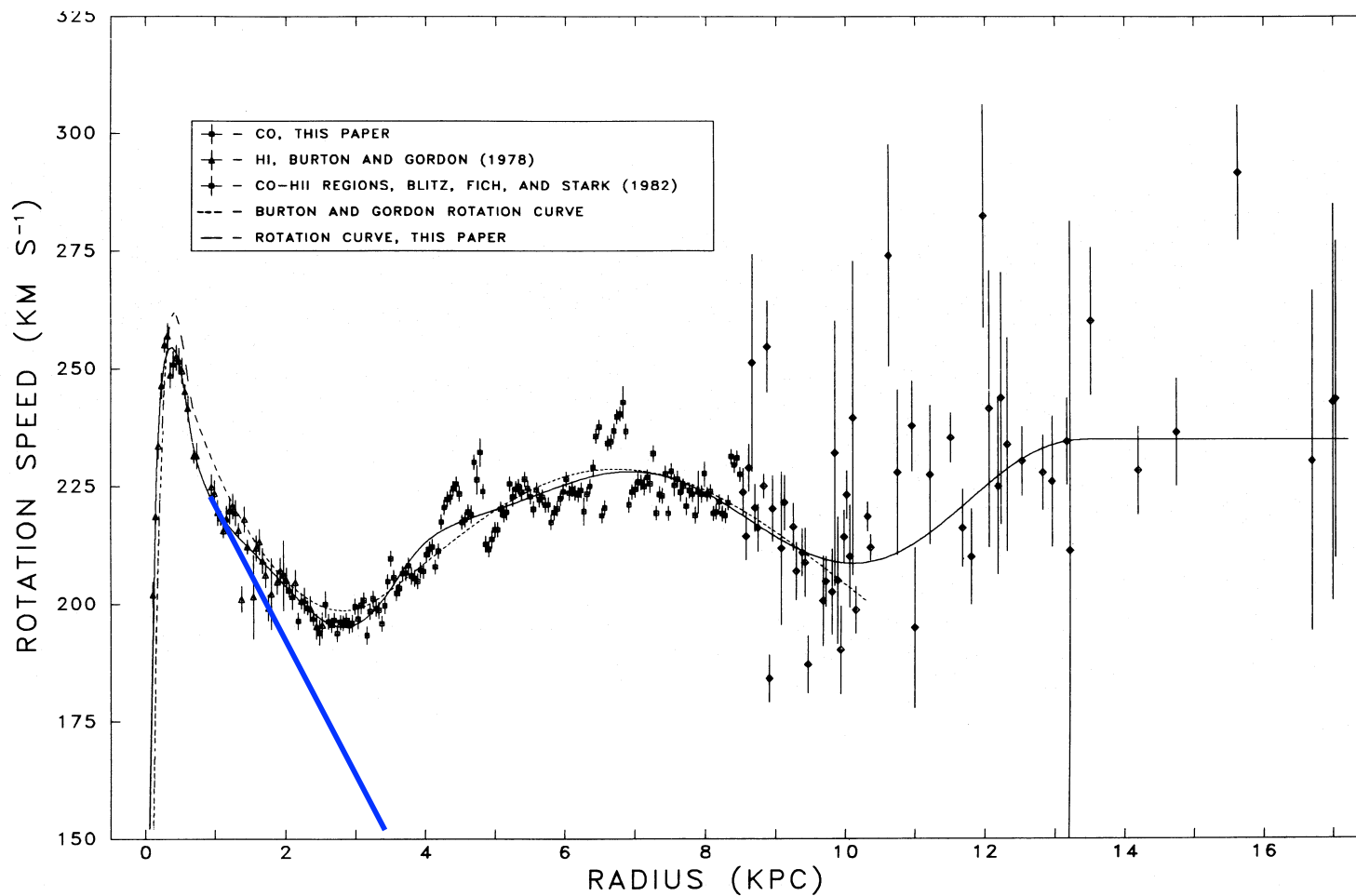

FIG. 3.—Plots of the rotation speed versus galactocentric radius. The solid lines correspond to the polynomials, and the dashed lines are the BG rotation curve. (upper panel) $(R_0, \theta_0) = (10 \text{ kpc}, 220 \text{ km s}^{-1})$; (lower panel) $(8.5 \text{ kpc}, 220 \text{ km s}^{-1})$.

© American Astronomical Society • Provided by the NASA Astrophysics Data System

Dark Matter: In 1933 by F. Zwicky. This plot from D. Clemens, 1985

The motivation is the nature of dark matter

The principle

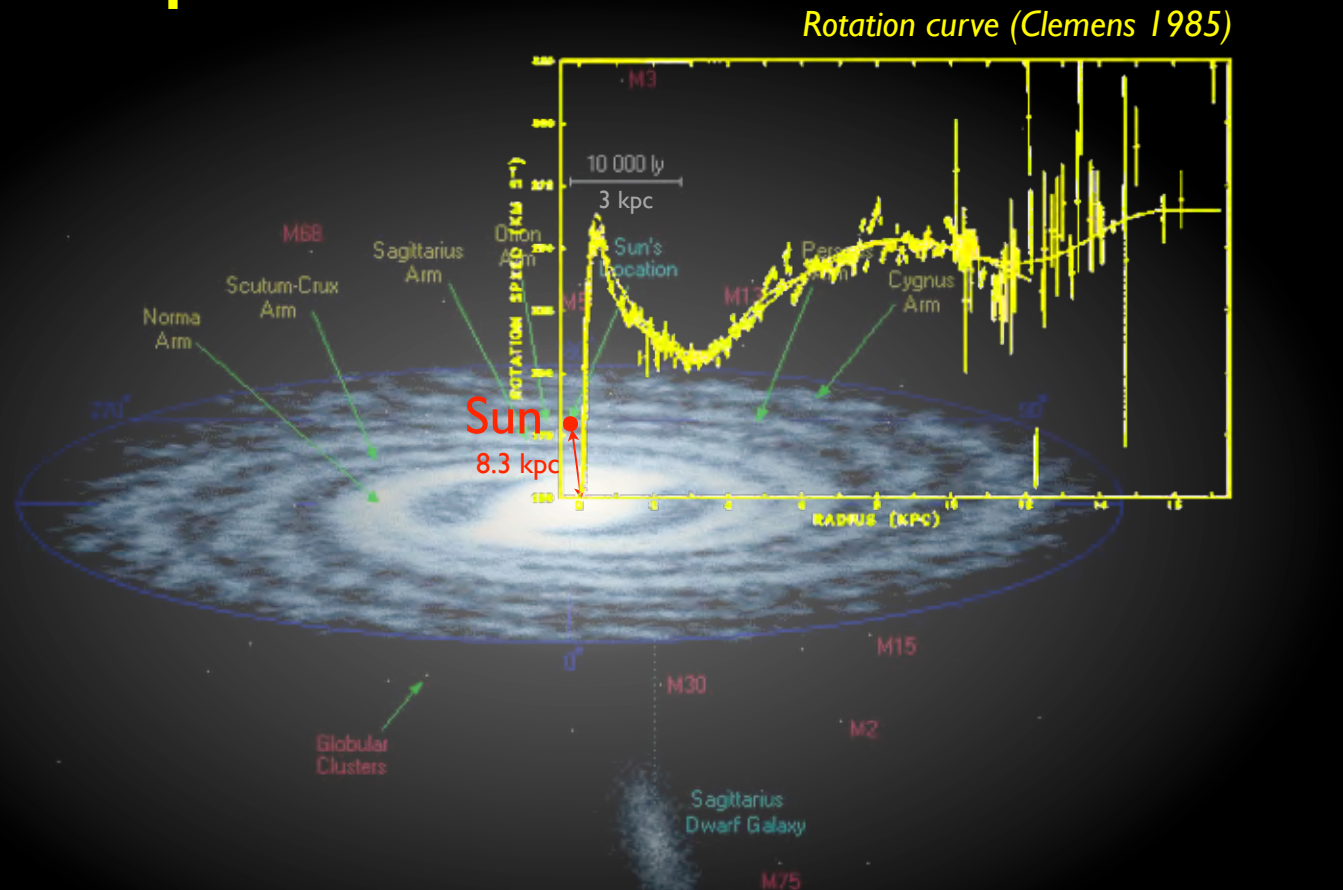

Our galaxy is inside a halo of dark matter particles

Image by R. Powell using DSS data

The motivation is the nature of dark matter

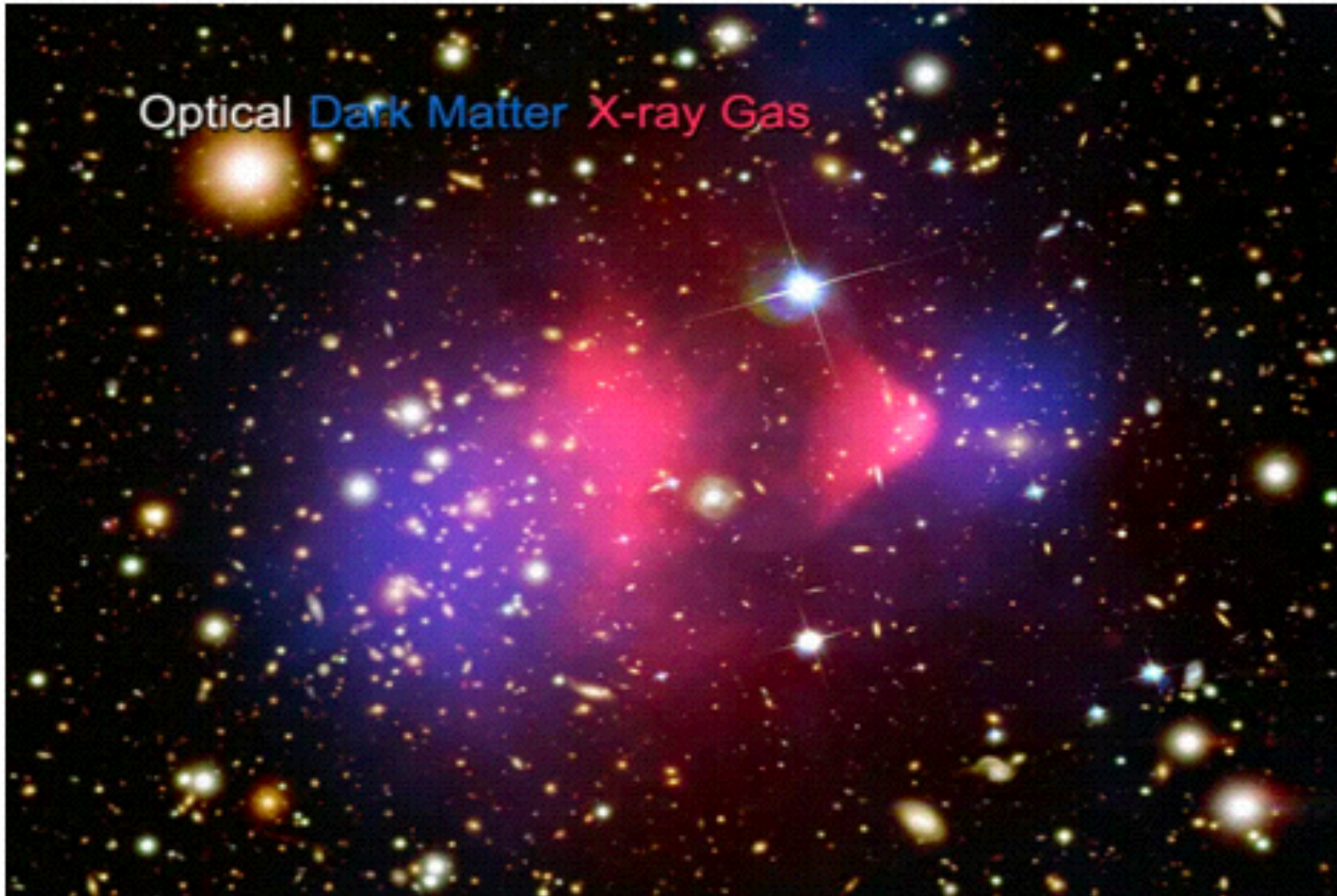

D. Clowe et al., "A direct empirical proof of the existence of dark matter",
Astrophys. J., Vol.648, L109 (2006). doi:10.1086/508162

The DAMA/LIBRA experiment

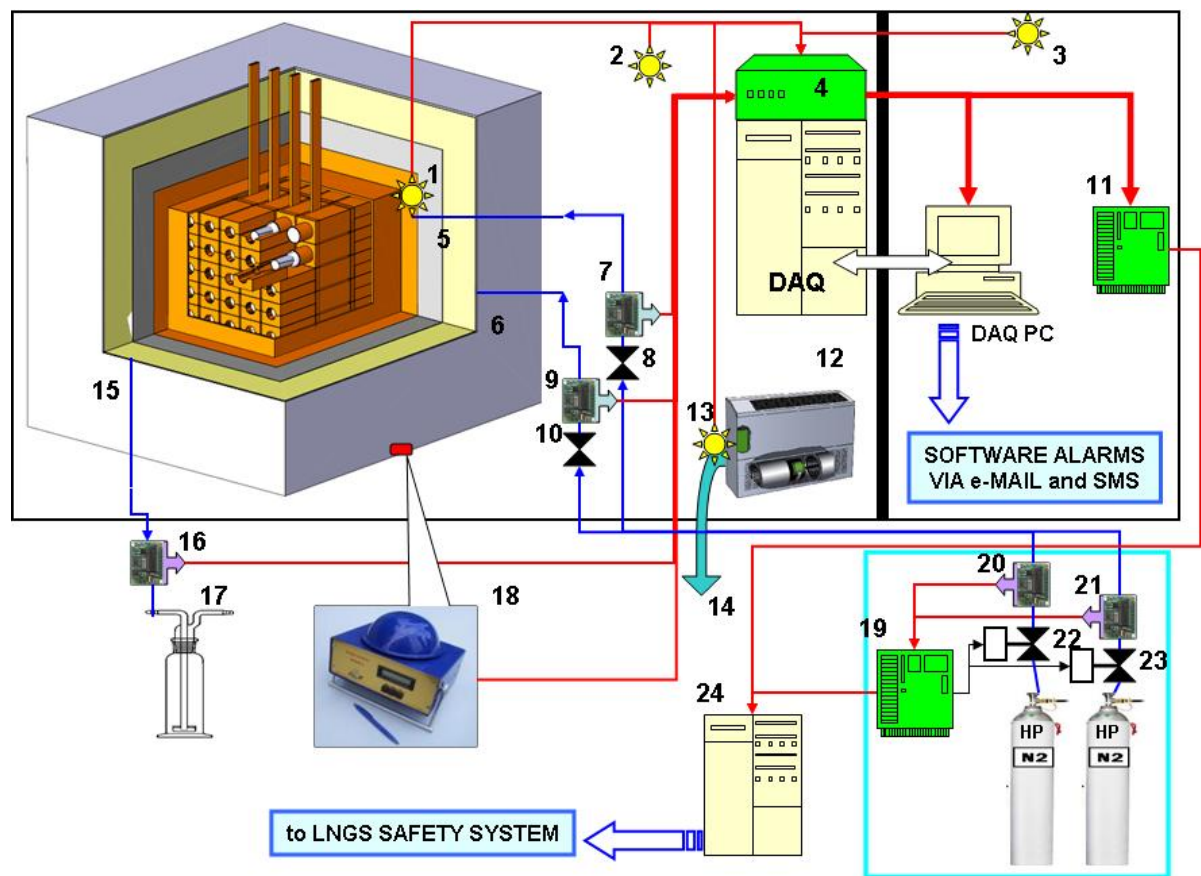

Bernabei et al.
 250 kg radiopure NaI(Tl)
 the Gran Sasso

NIM A592:297-315,2008

The DAMA/LIBRA experiment

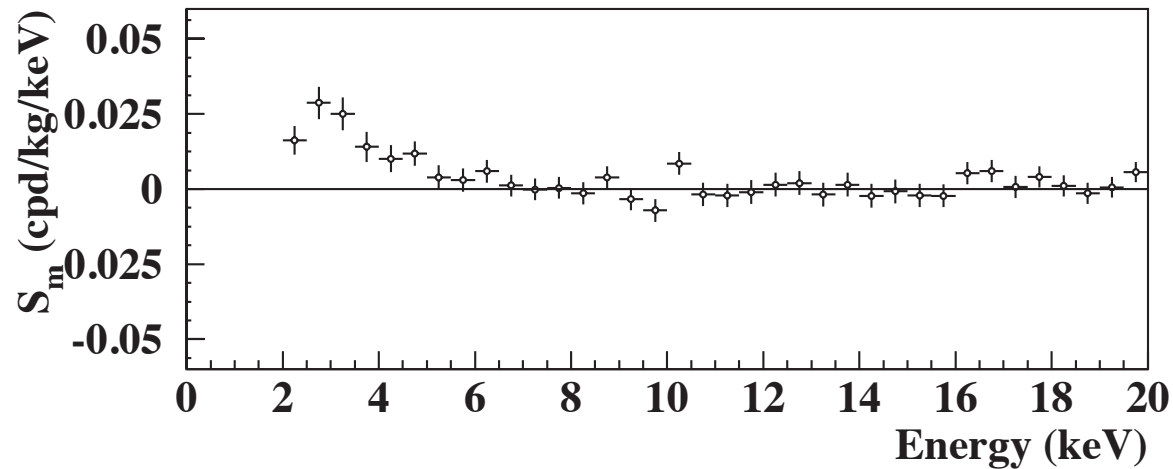

2-6 keV

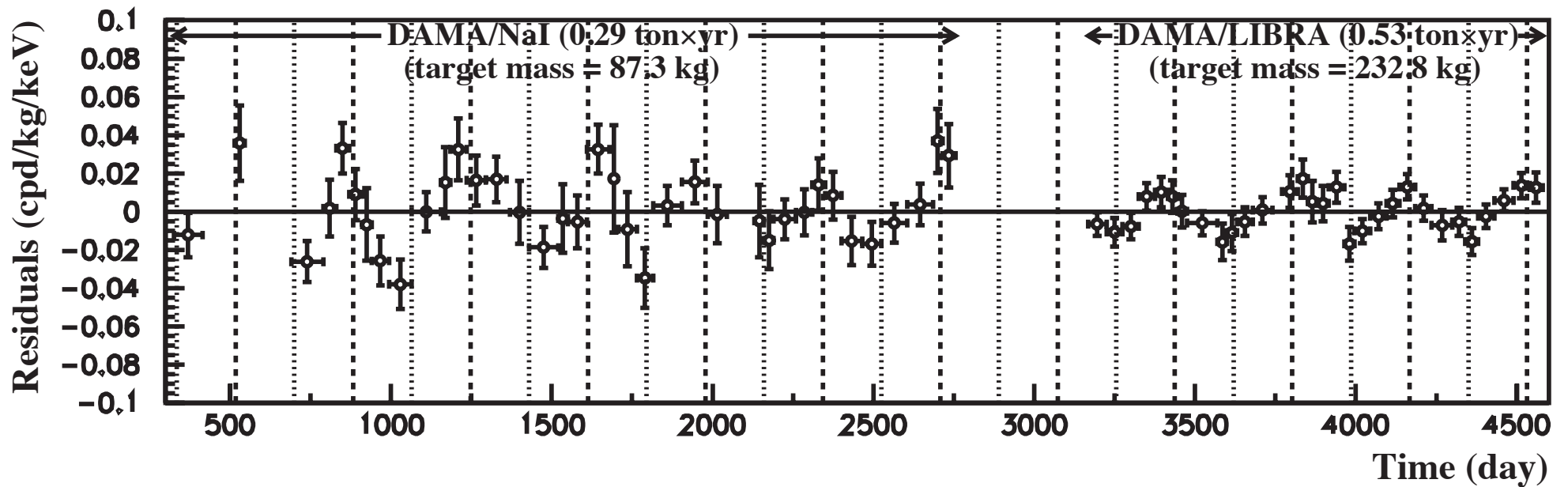

DAMA collab., arXiv:0884.2741

The DAMA/LIBRA experiment

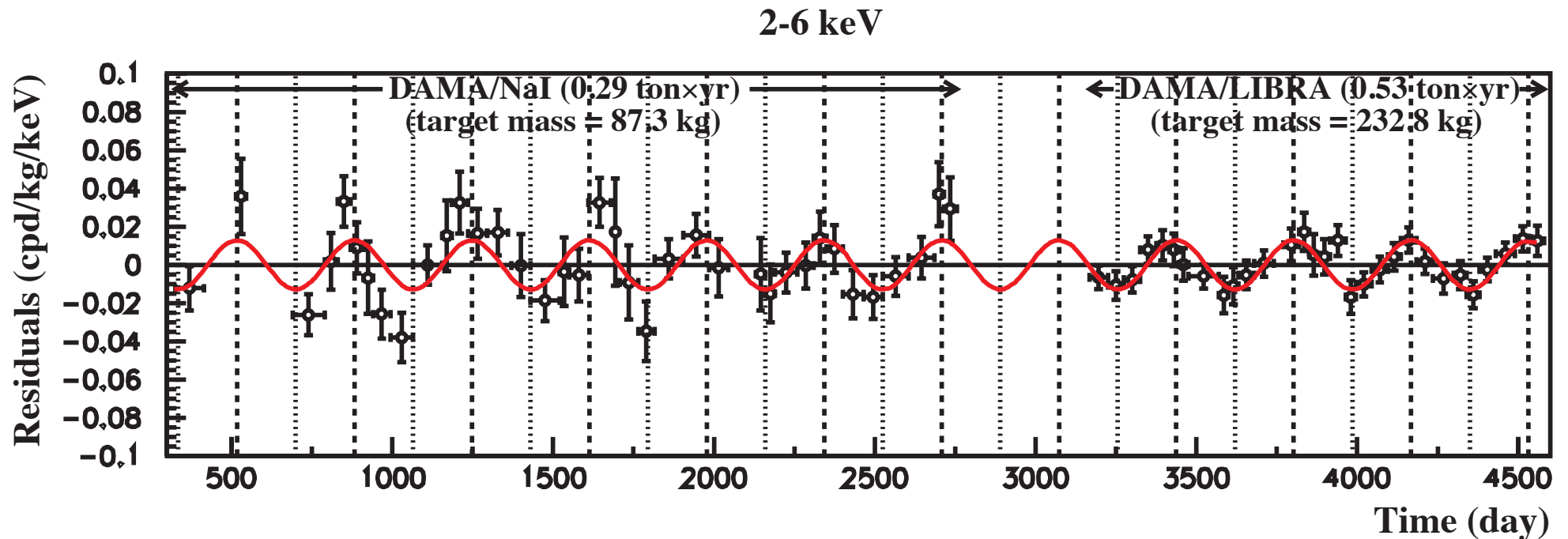

DAMA collab., arXiv:0884.2741

Recoil detection of the massive particle.

Where is the gauge boson?

The theory of DM

Arkani-Hamed, Finkbeiner, Slatyer, Weiner
Pospelov & Ritz

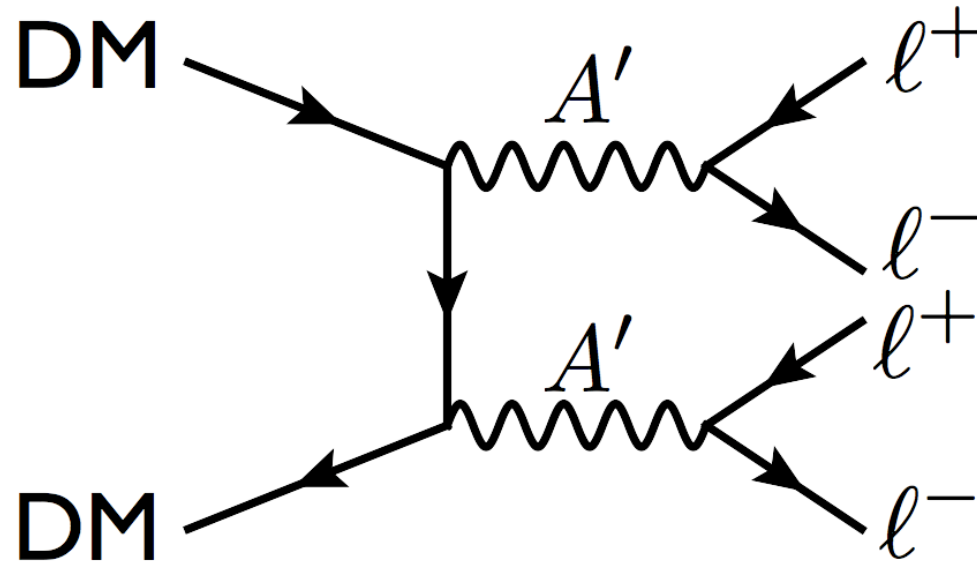

$m_{\text{DM}} \sim \text{TeV}$

$m_{A'} \sim \text{GeV}$

no anti-protons

also: A' generates long-range force
(Sommerfeld enhancement)

$$\langle \sigma v \rangle \propto \frac{1}{v}$$

Motivation for light dark photon

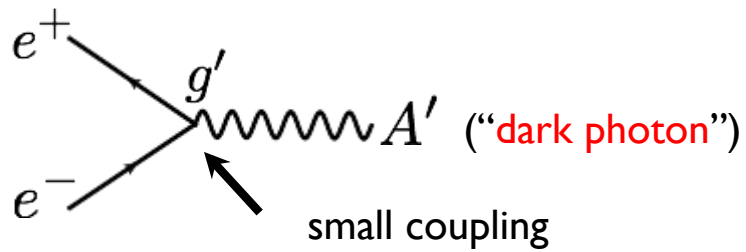

$$\alpha' \equiv \frac{g'^2}{4\pi}$$

- Large interest in A' search
- Number of considerations

naturally give A' mass $\sim 1 - 100\text{s MeV}$

DM annihilation

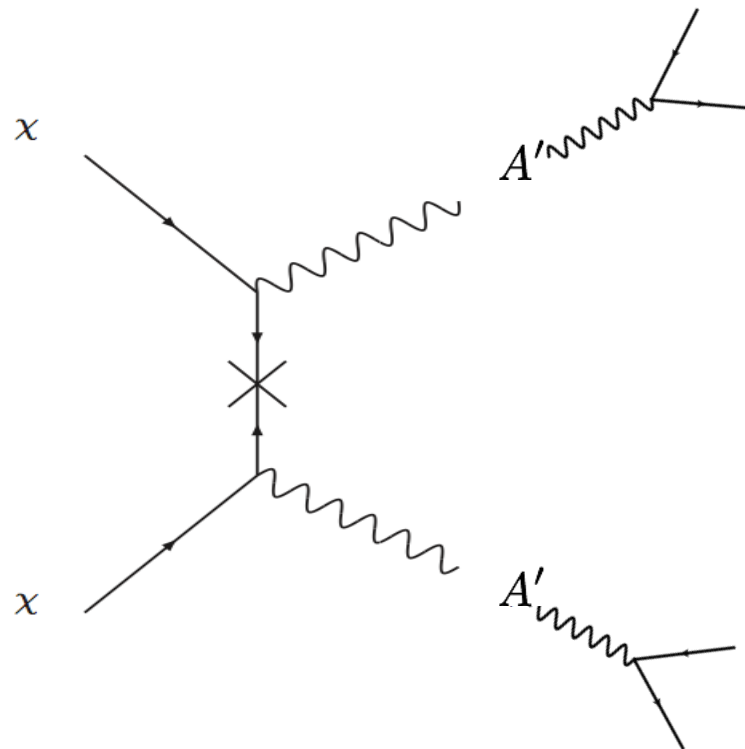

Motivation for light dark photon

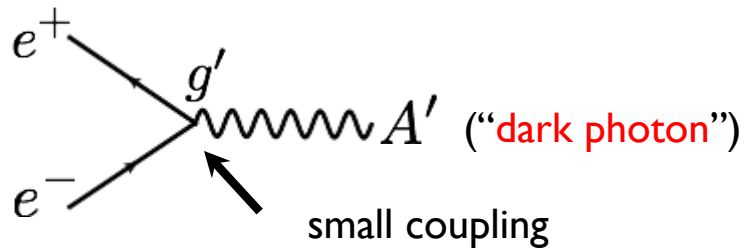

$$\alpha' \equiv \frac{g'^2}{4\pi}$$

- Large interest in A' search
- Number of considerations

naturally give A' mass $\sim 1 - 100\text{s MeV}$

Positron/electron
intensity ratio

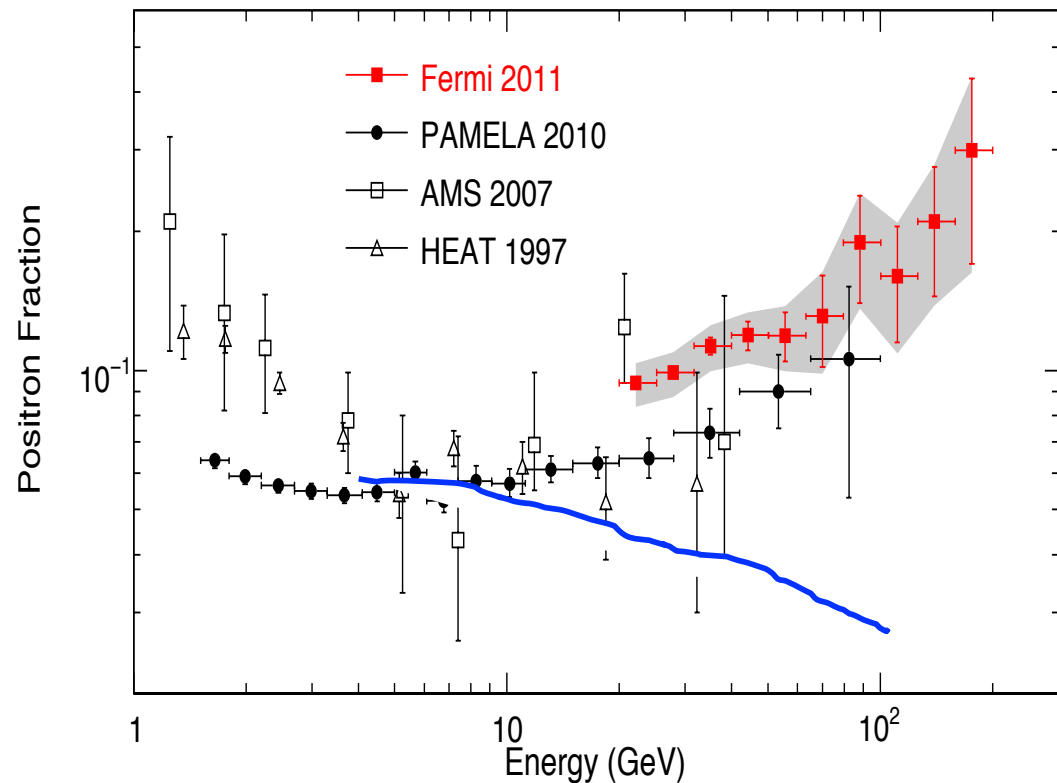

Motivation for light dark photon

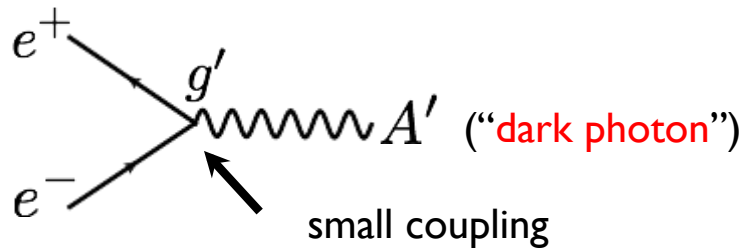

$$\alpha' \equiv \frac{g'^2}{4\pi}$$

- Large interest in A' search
- Number of considerations

naturally give A' mass $\sim 1 - 100$ s MeV

Antiproton/proton
intensity ratio

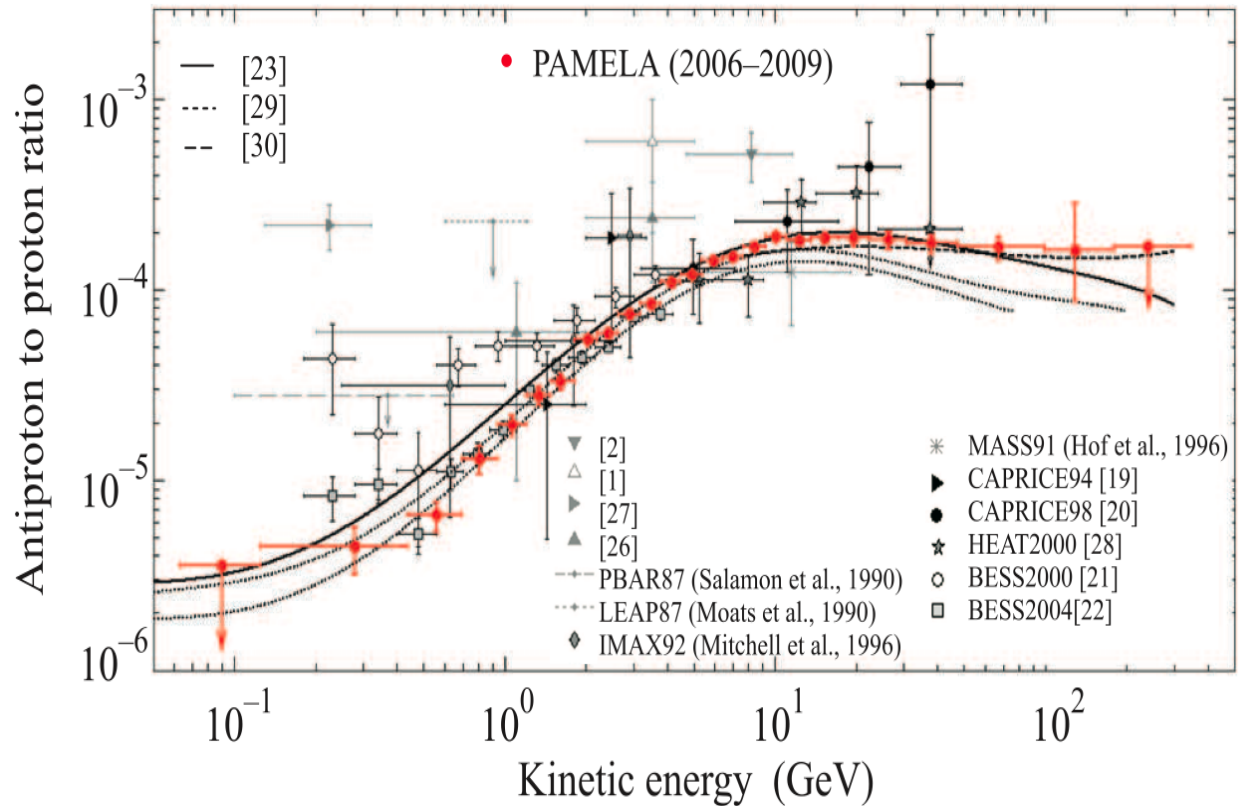

Motivation for light dark photon

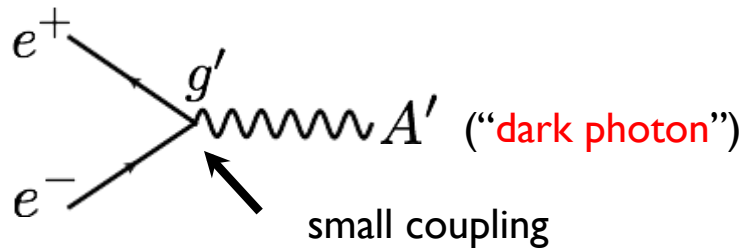

$$\alpha' \equiv \frac{g'^2}{4\pi}$$

- Large interest in A' search
- Number of considerations

naturally give A' mass $\sim 1 - 100\text{s MeV}$

DM annihilation

Positron/electron

Antiproton/proton

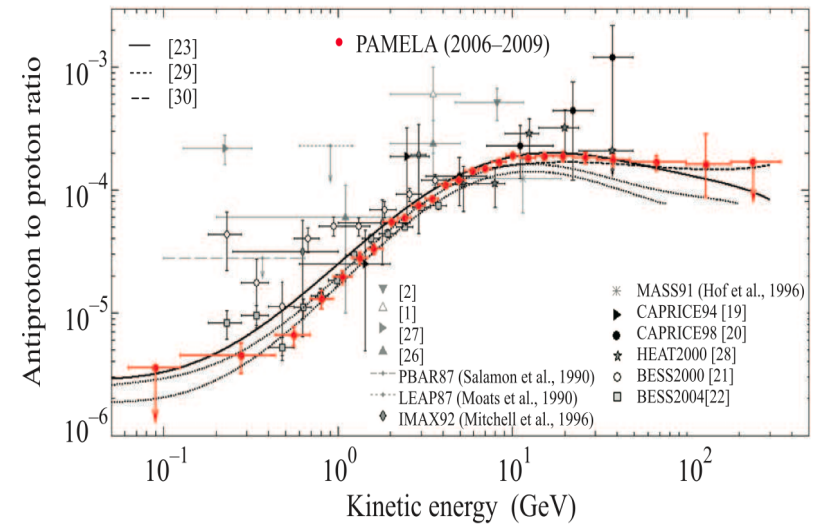
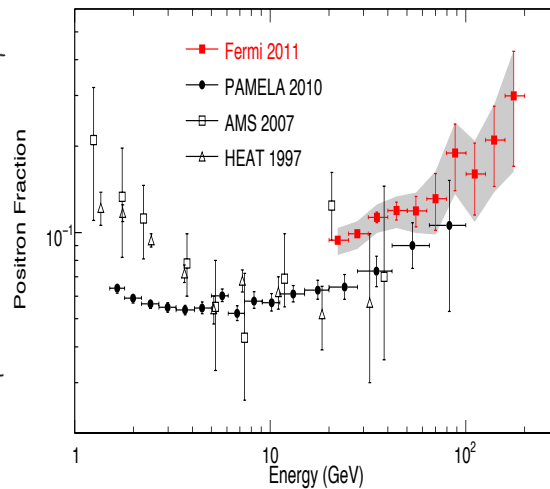
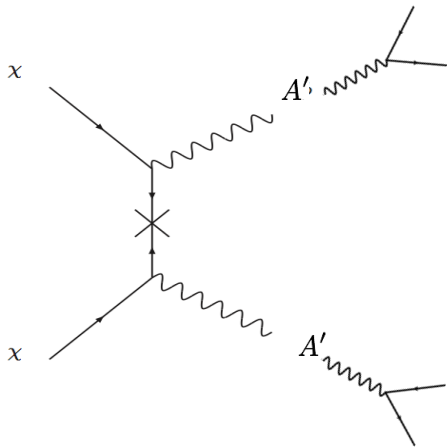

Motivation for light dark photon

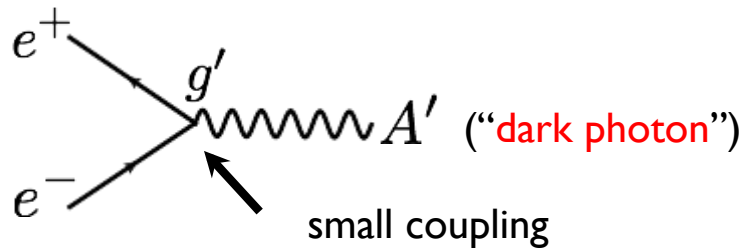

$$\alpha' \equiv \frac{g'^2}{4\pi}$$

- Large interest in A' search
- Number of considerations

naturally give A' mass $\sim 1 - 100$ s MeV

DM annihilation Positron/electron

Antiproton/proton

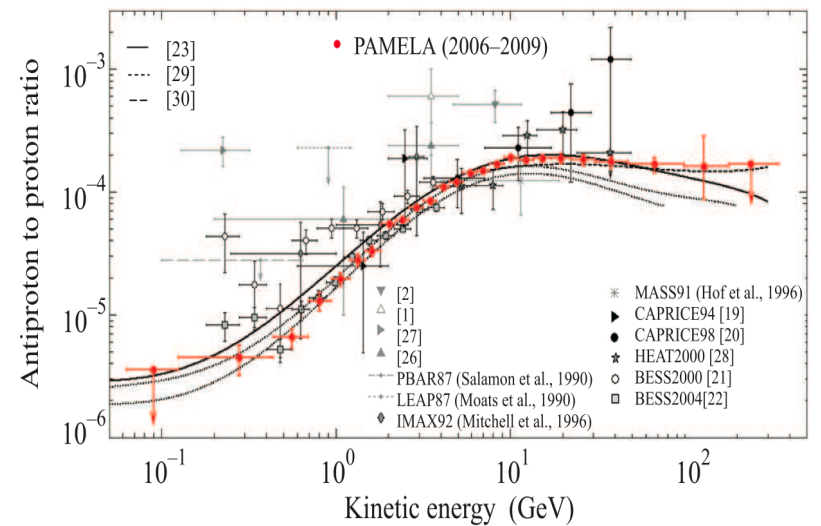
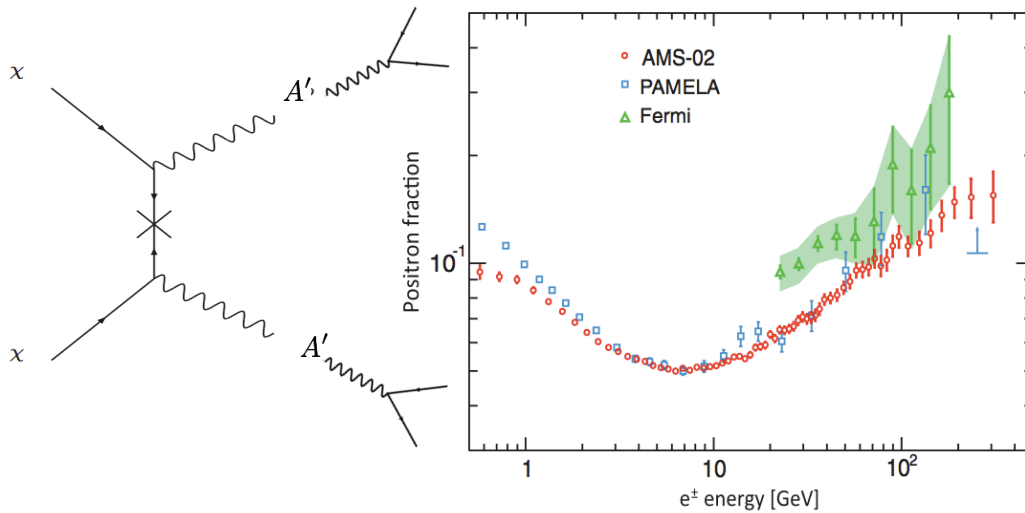

How to search for new physics

The photon and A' can mix !

Holdom
Galison, Manohar

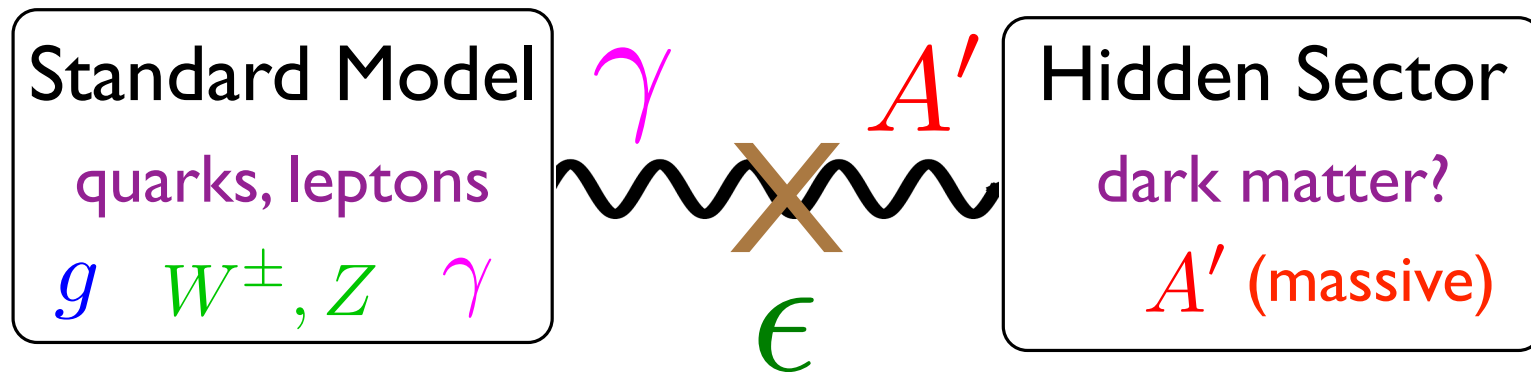

mixing induces coupling between
ordinary matter and hidden sector matter

How to search for new physics



ϵ = mixing strength

Generated by heavy particles
X interacting with γ and A'

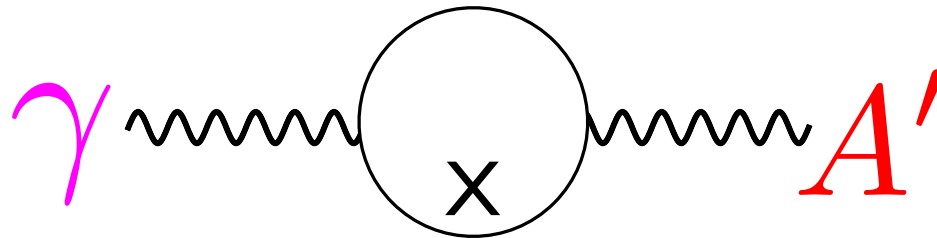

$$\Delta\mathcal{L} = \frac{\epsilon}{2} F^{Y,\mu\nu} F'_{\mu\nu} \quad \text{“Kinetic Mixing”}$$

ϵ could even be $O(1)$ (theoretically)

How to search for new physics



ϵ = mixing strength

Generated by heavy particles
X interacting with γ and A'

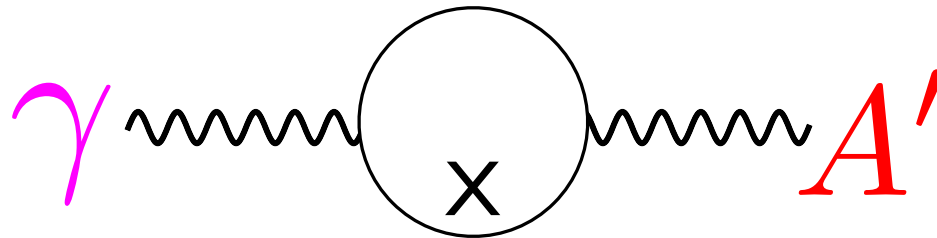

$$\epsilon \sim 10^{-8} - 10^{-2}$$

natural from quantum
fluctuations of heavy
particles

Where to search for new physics

Report of the Workshop held December 2011 in Rockville, MD

arXiv:1205.2671v1 [hep-ex] 11 May 2012

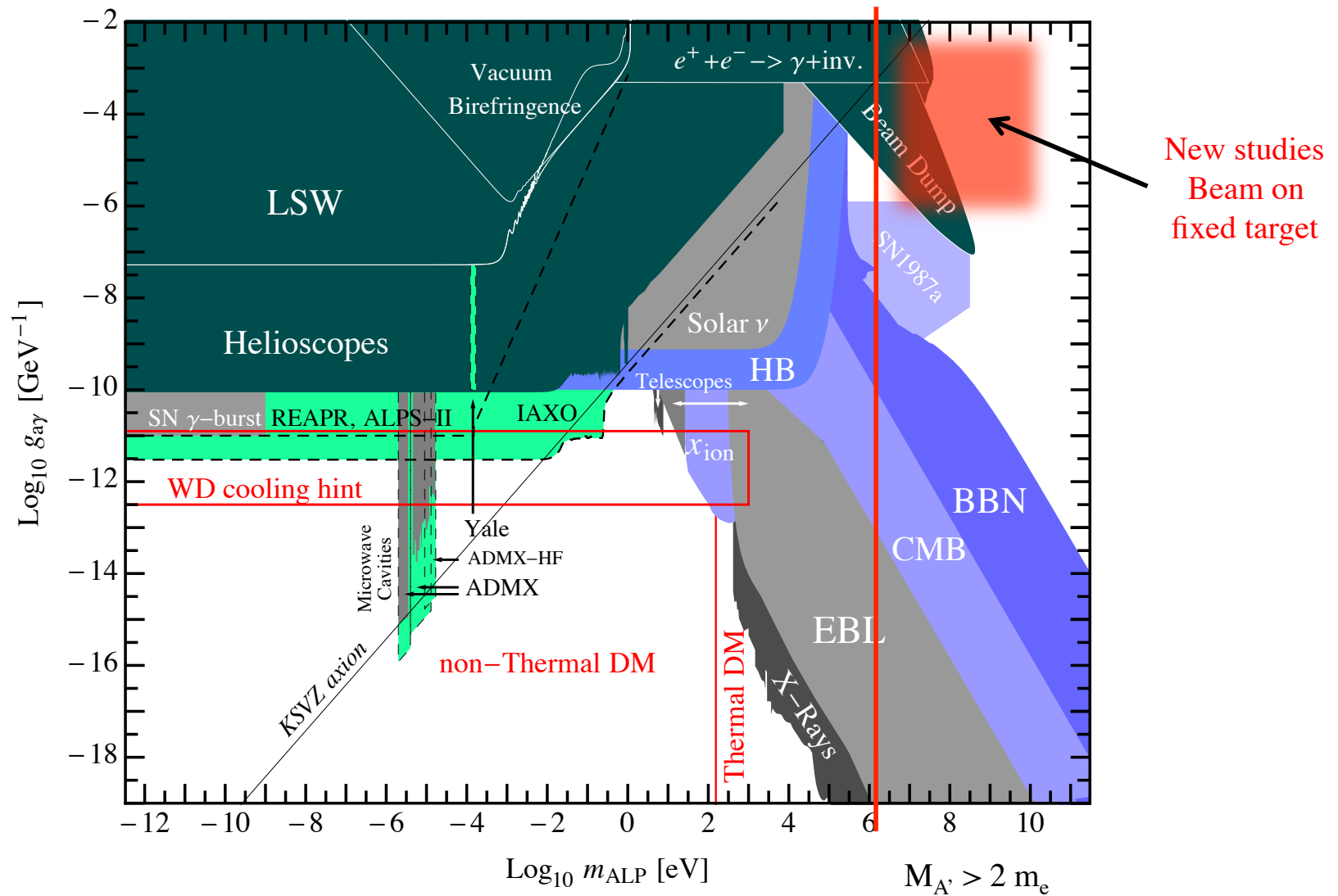

Recent summary of the searches

- g-2 of muon and electron
- Missing particle in e+e- to ..
- Decay to SM (e+/e-) -
Beam Dump
Mass reconstruction

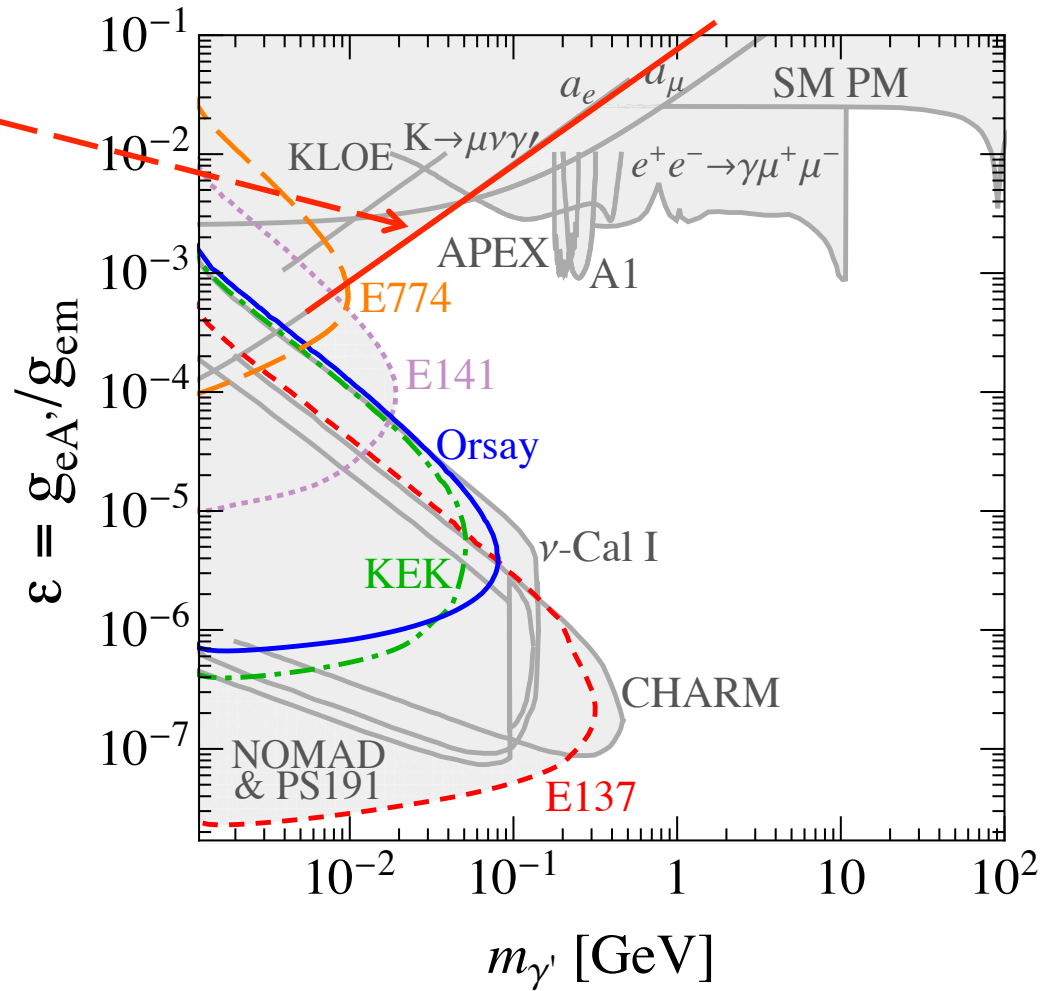

S. Andreas, C. Niebuhr, A. Ringwald, arXiv:1209.6083

Recent summary of the searches

g-2 of muon and electron

Missing particle in e^+e^- to $\gamma A'$

Decay to SM (e^+/e^-) -
Beam Dump
Mass reconstruction

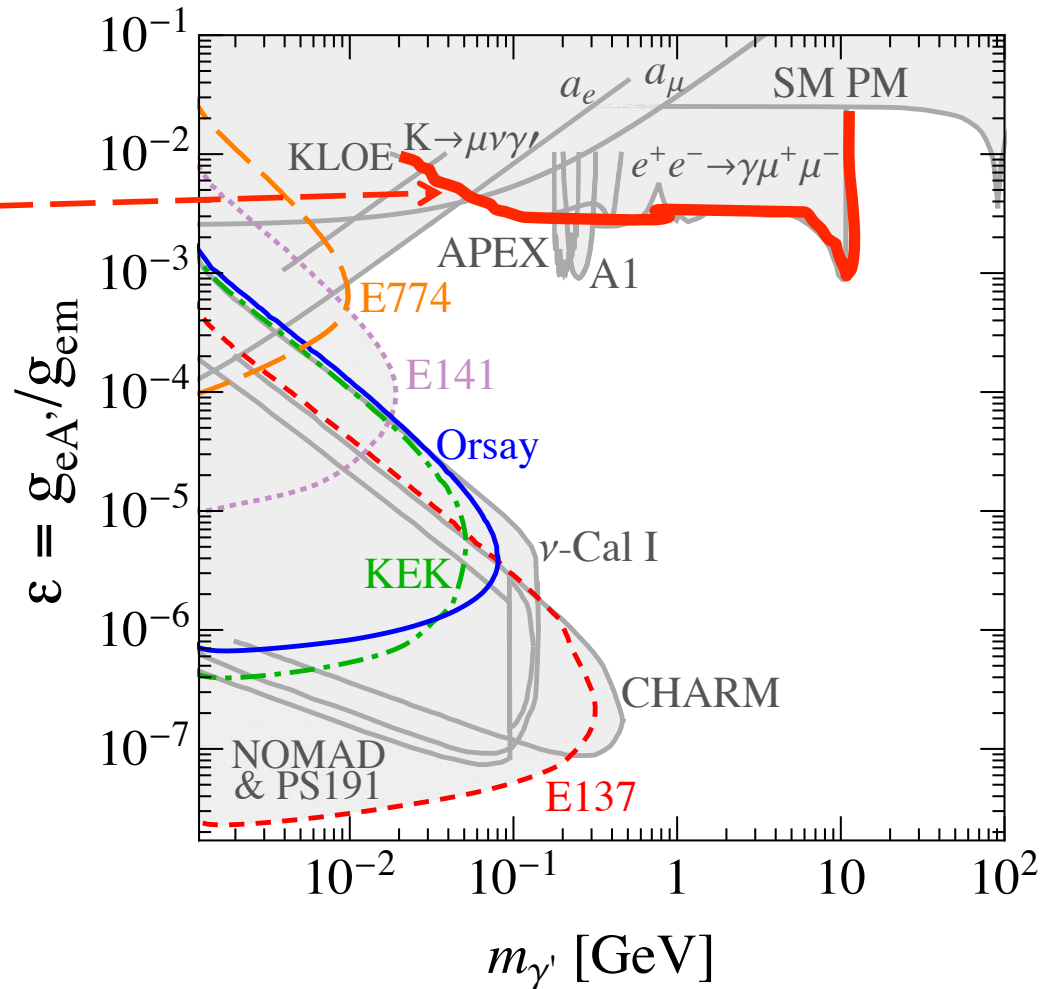

S. Andreas, C. Niebuhr, A. Ringwald, arXiv:1209.6083

Recent summary of the searches

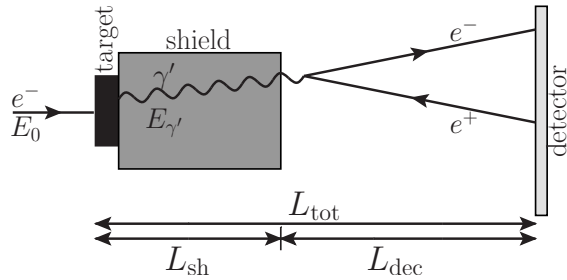

No mass reconstruction

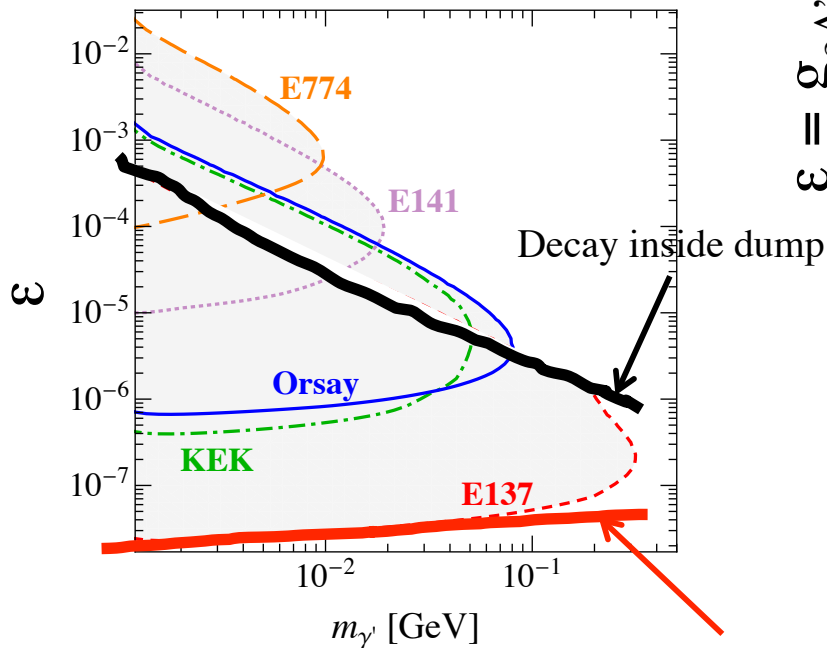

Statistics limitation

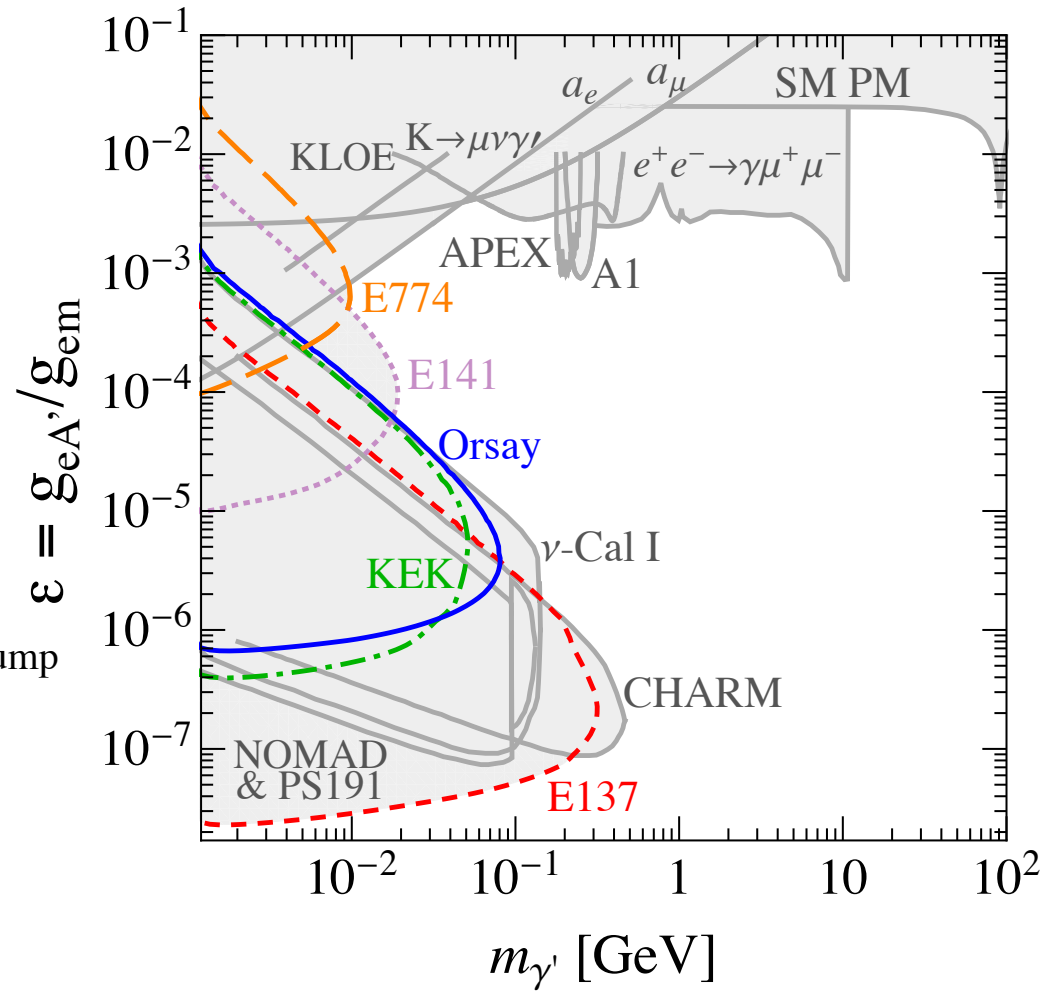

S. Andreas, C. Niebuhr, A. Ringwald, arXiv:1209.6083

Recent summary of the searches

g-2 of muon and electron

Missing particle in e+e- to ..

Decay to SM (e+/e-) -

Beam Dump

Mass reconstruction

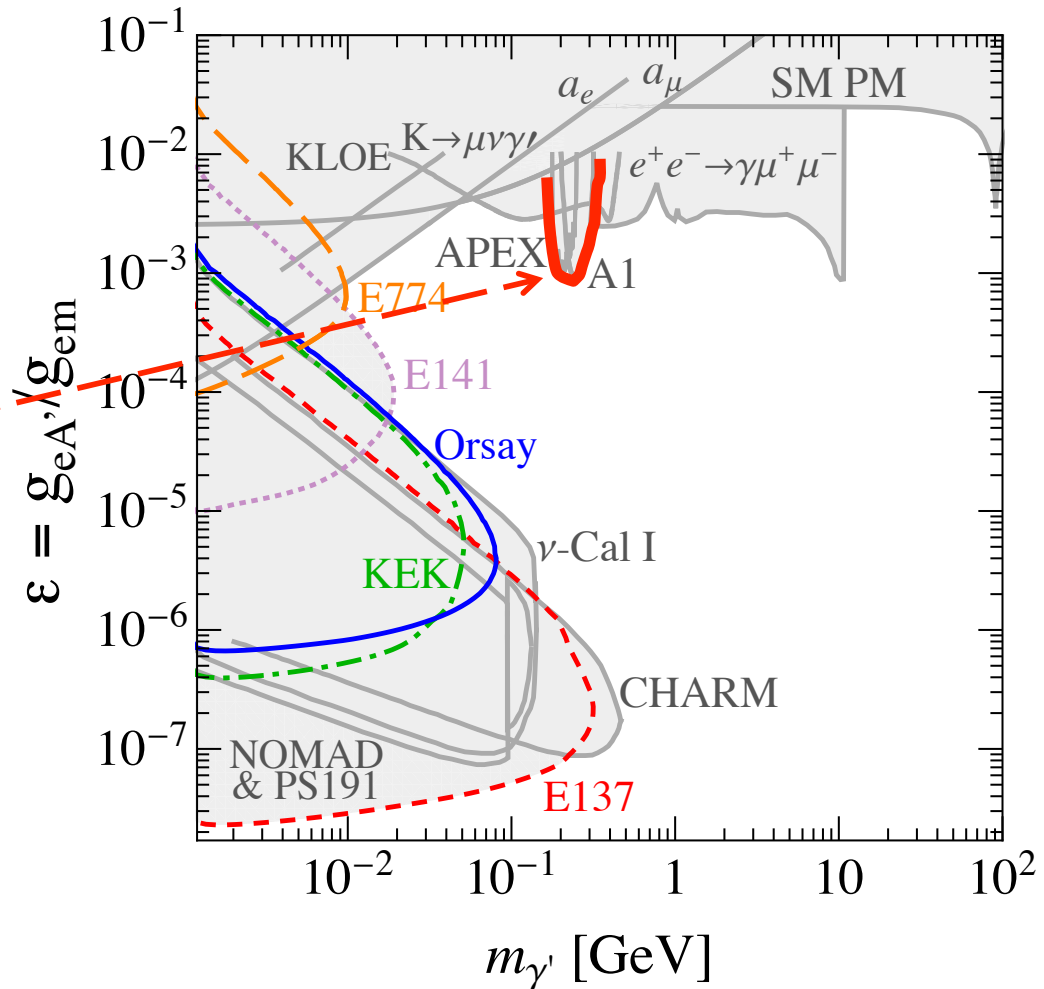

S. Andreas, C. Niebuhr, A. Ringwald, arXiv:1209.6083

Ways to search for a new particle

$$e^+e^- \leftrightarrow \gamma^* \text{ and } e^+e^- \leftrightarrow A'$$

- Search for a bump in the mass spectra
- As it was done - Vector Mesons, Z, H
- Required beam: energy, intensity, duty factor
- How small is the e^+e^- decay branching fraction?

Ways to search for a new particle

$$e^+e^- \leftrightarrow \gamma^* \text{ and } e^+e^- \leftrightarrow A'$$

- Maximize production rate of virtual photons, γ^*
- Optimization of the mass resolution, $\sigma_{m_{\gamma^*}}$
- Optimization of the detector acceptance

How look for A' with MeV-GeV mass?

e^+e^- colliders

RE, Schuster, Toro
Batell, Pospelov, Ritz
Reece, Wang
Borodatchenkova et.al.
Fayet

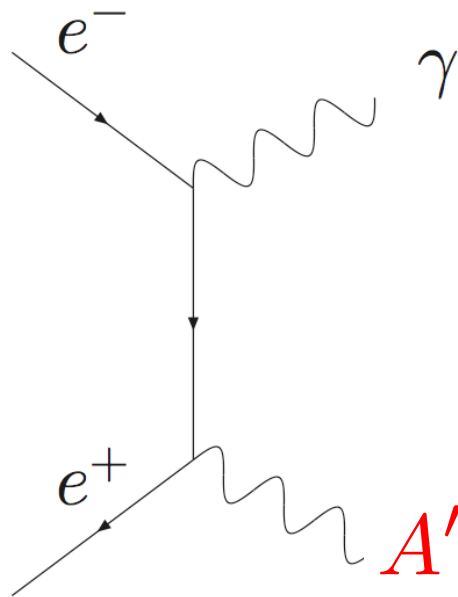

Rare meson decays

$$\phi \rightarrow \eta A'$$

$$\pi^0 \rightarrow \gamma A'$$

slide from R.Essig lecture at PATRAS2012

How look for A' with MeV-GeV mass?

New e^- fixed target experiments

Bjorken, RE, Schuster, Toro
Freytsis, Ovanesyan, Thaler
Reece & Wang

Detect both e^+ and e^- : mass reconstruction

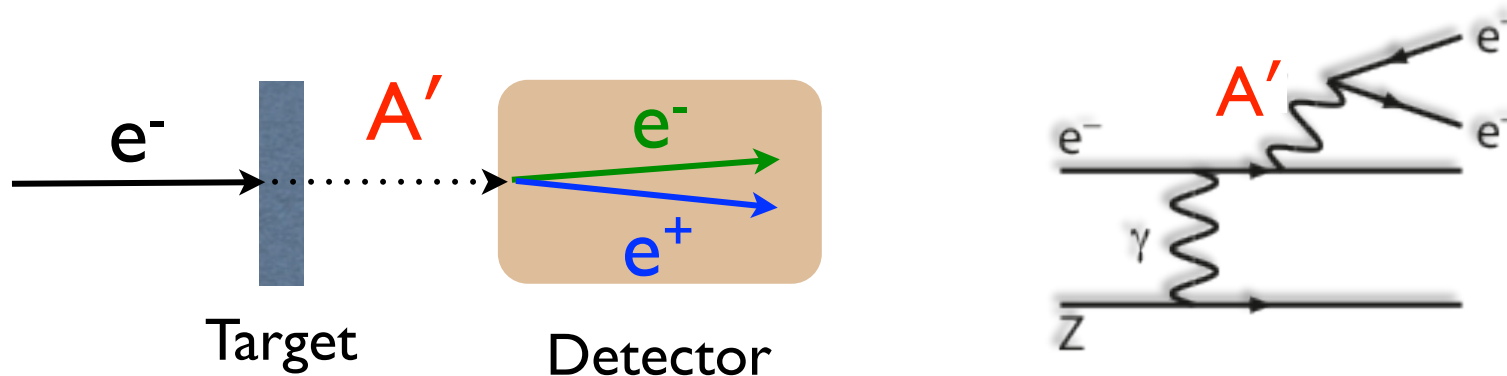

Experiments done/planned at

- Jefferson Lab (APEX, HPS, DarkLight)

slide from R.Essig lecture at PATRAS2012

Searches for a gauge boson A' at JLab

Jefferson Lab site

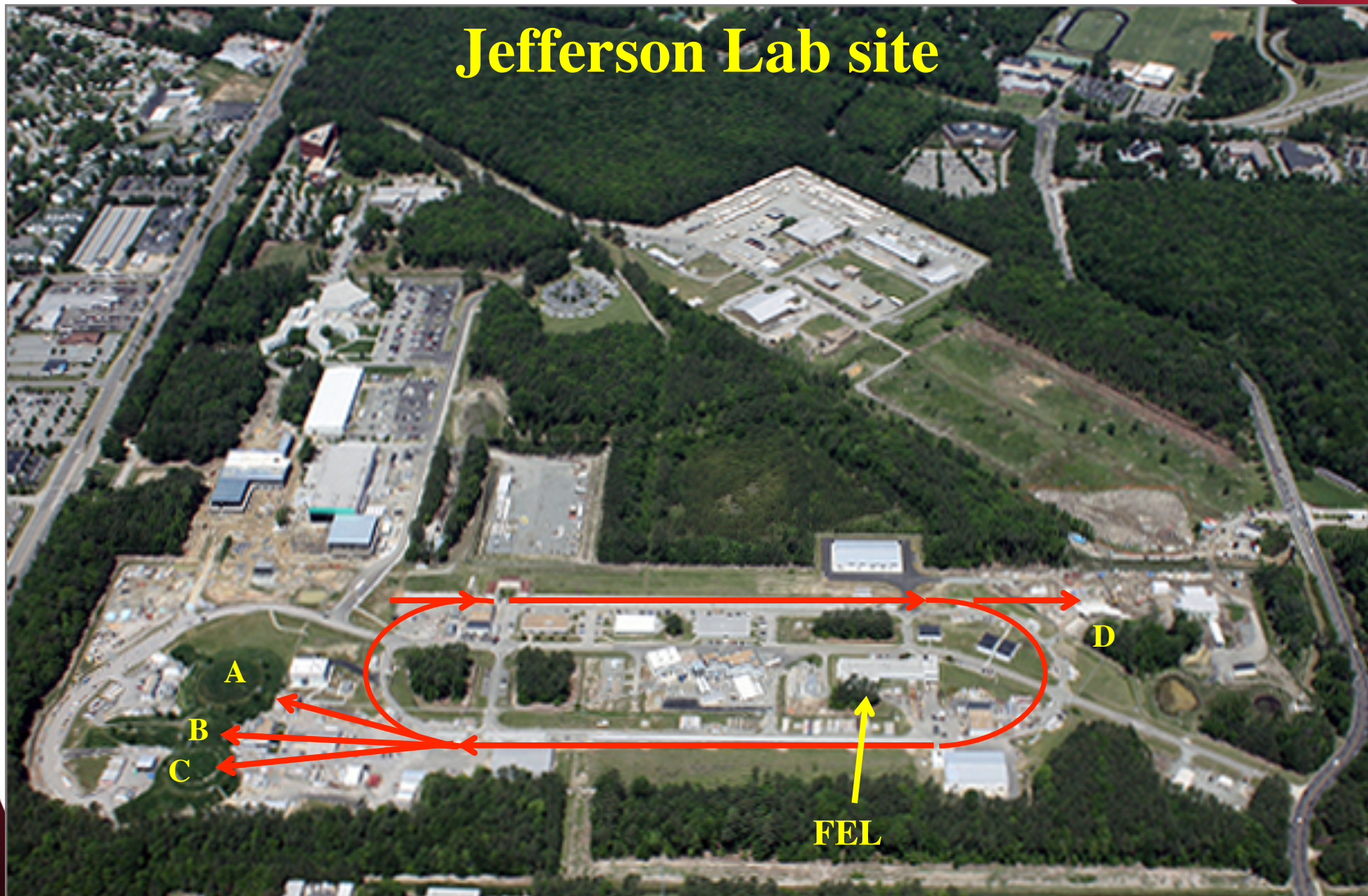

Searches for a gauge boson A' at JLab

APEX

Direct production at JLab

- ▶ Produce low mass hidden gauge bosons with weak coupling to SM via high energy electron beam incident on fixed high-Z (Ta) target
- ▶ A' decays to e^+e^- pair with opening angle $\sim m_{A'}/E_b$

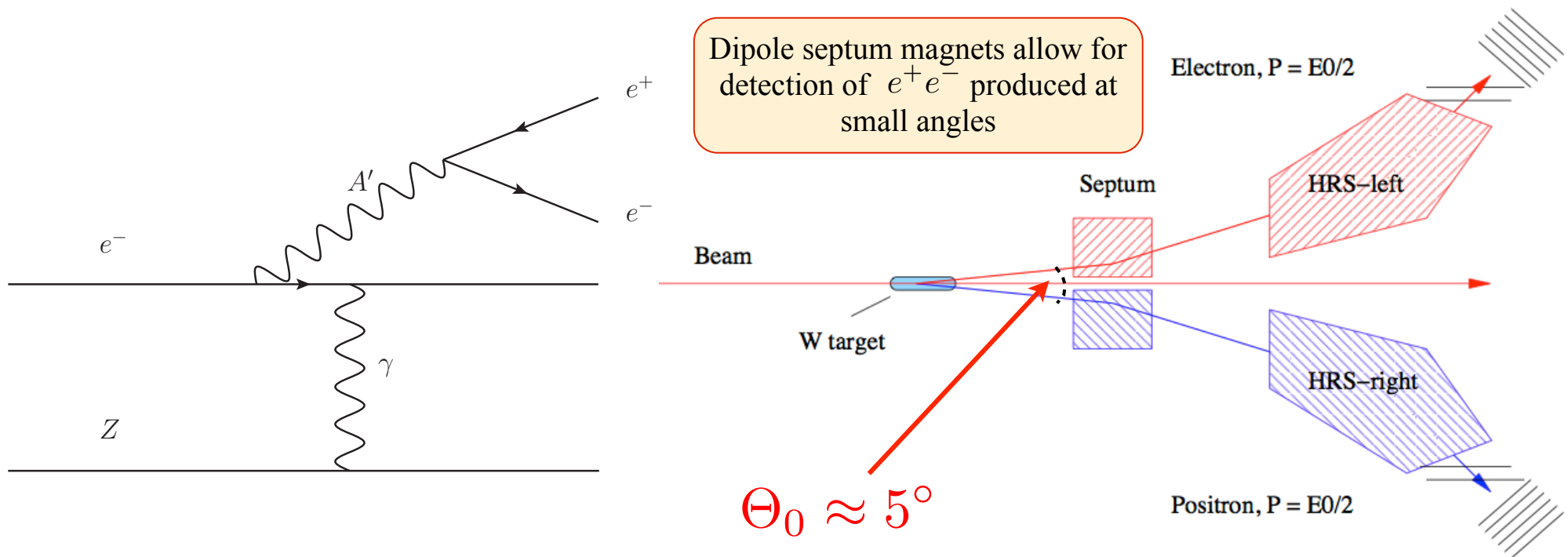

Searches for a gauge boson A' at JLab

APEX

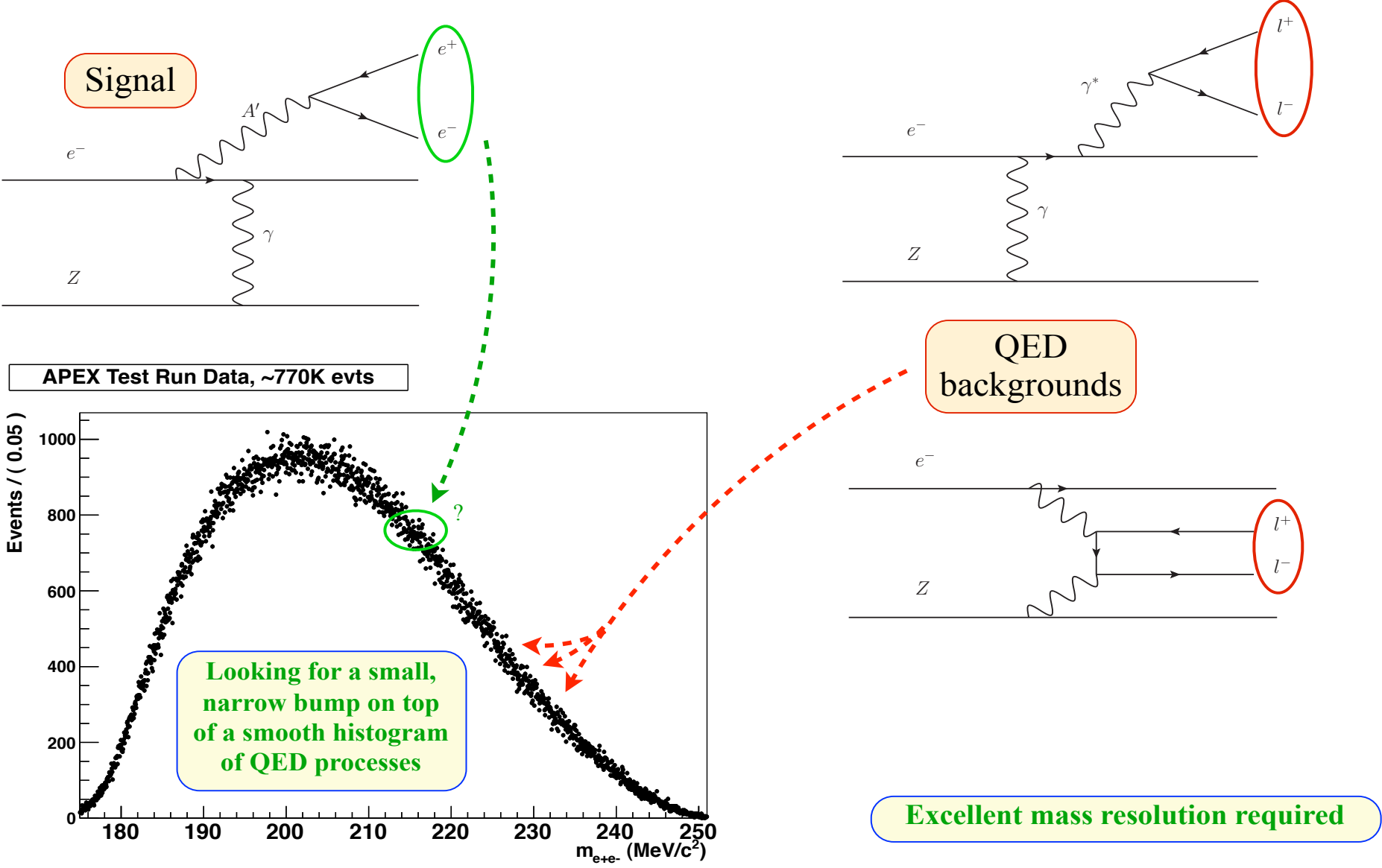

Searches for a gauge boson A' at JLab

APEX

Bump hunt / resonance search

Final invariant mass spectrum QED radiative trident / Bethe-Heitler events

- Bump hunt for small, narrow resonance

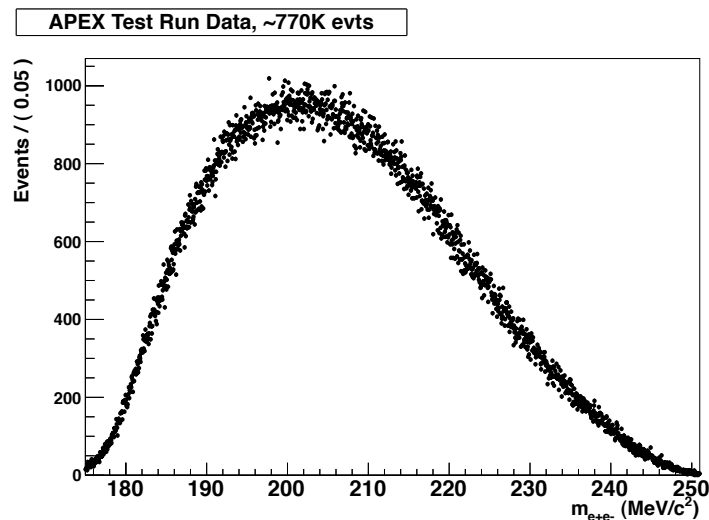

Test run mass resolution: $\sigma \sim 0.85 - 1.11$ MeV

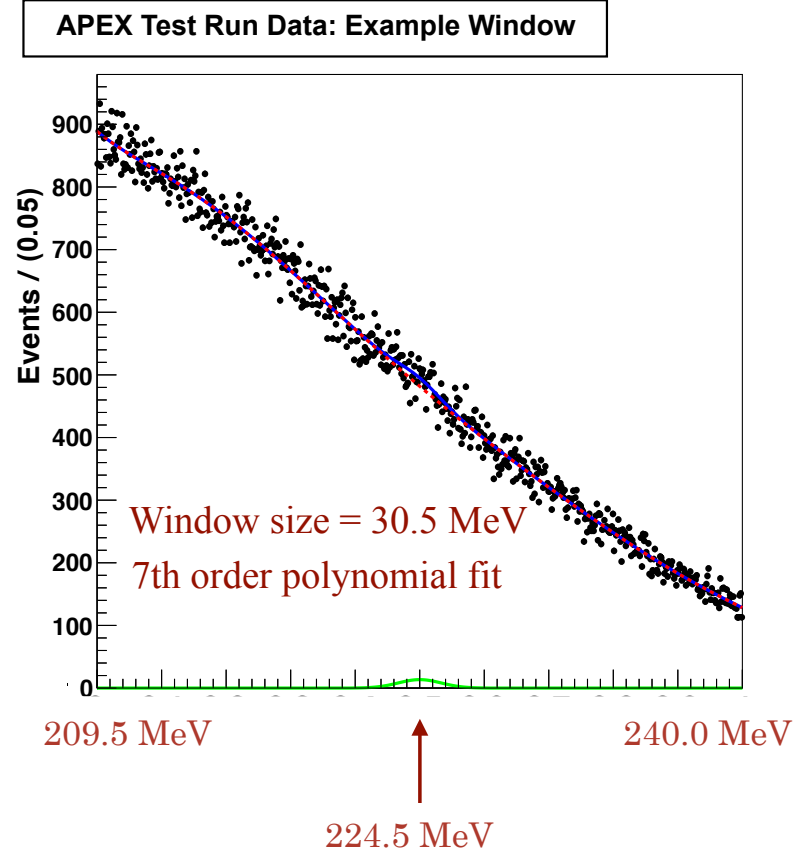

Searches for a gauge boson A' at JLab

Heavy Photon Search

- Compact large forward acceptance spectrometer
- Silicon tracker/vertexer, inside magnet close (10cm!) to target

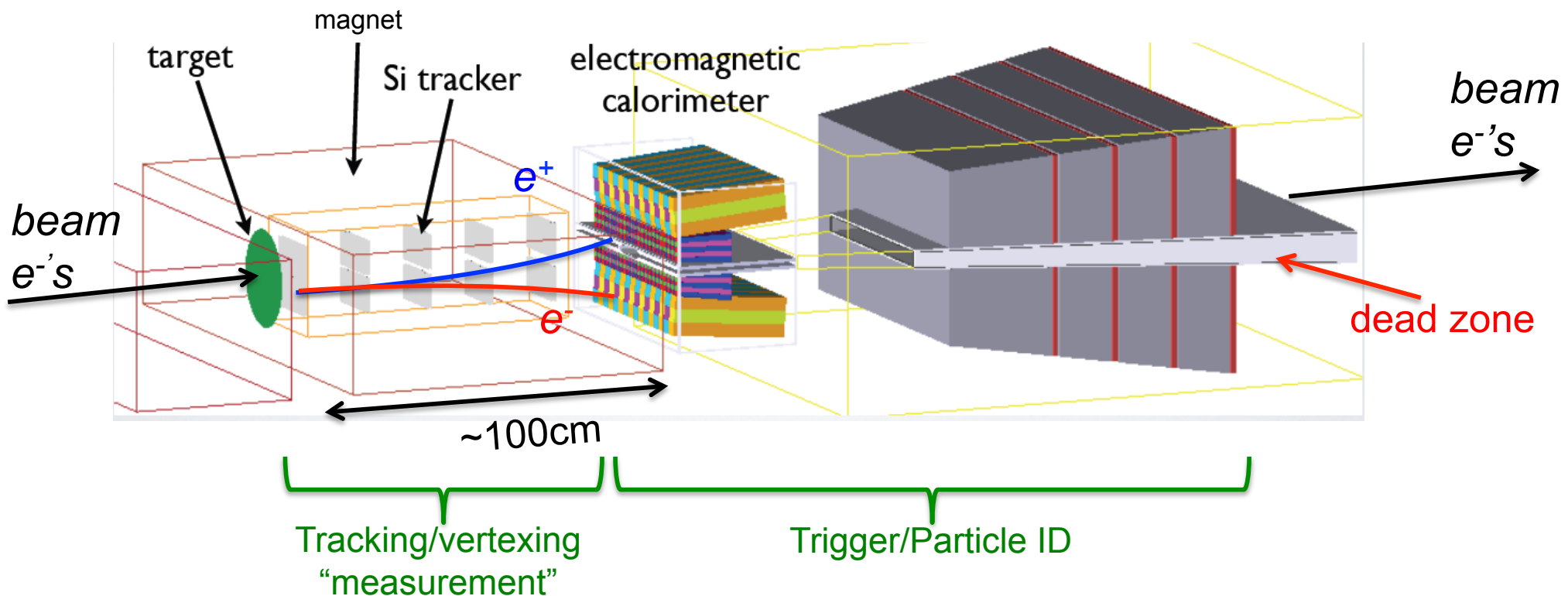

- All detectors split vertically to avoid "sheet of flame"
 - Primary beam, degraded electrons, bremsstrahlung photons, etc.

Searches for a gauge boson A'

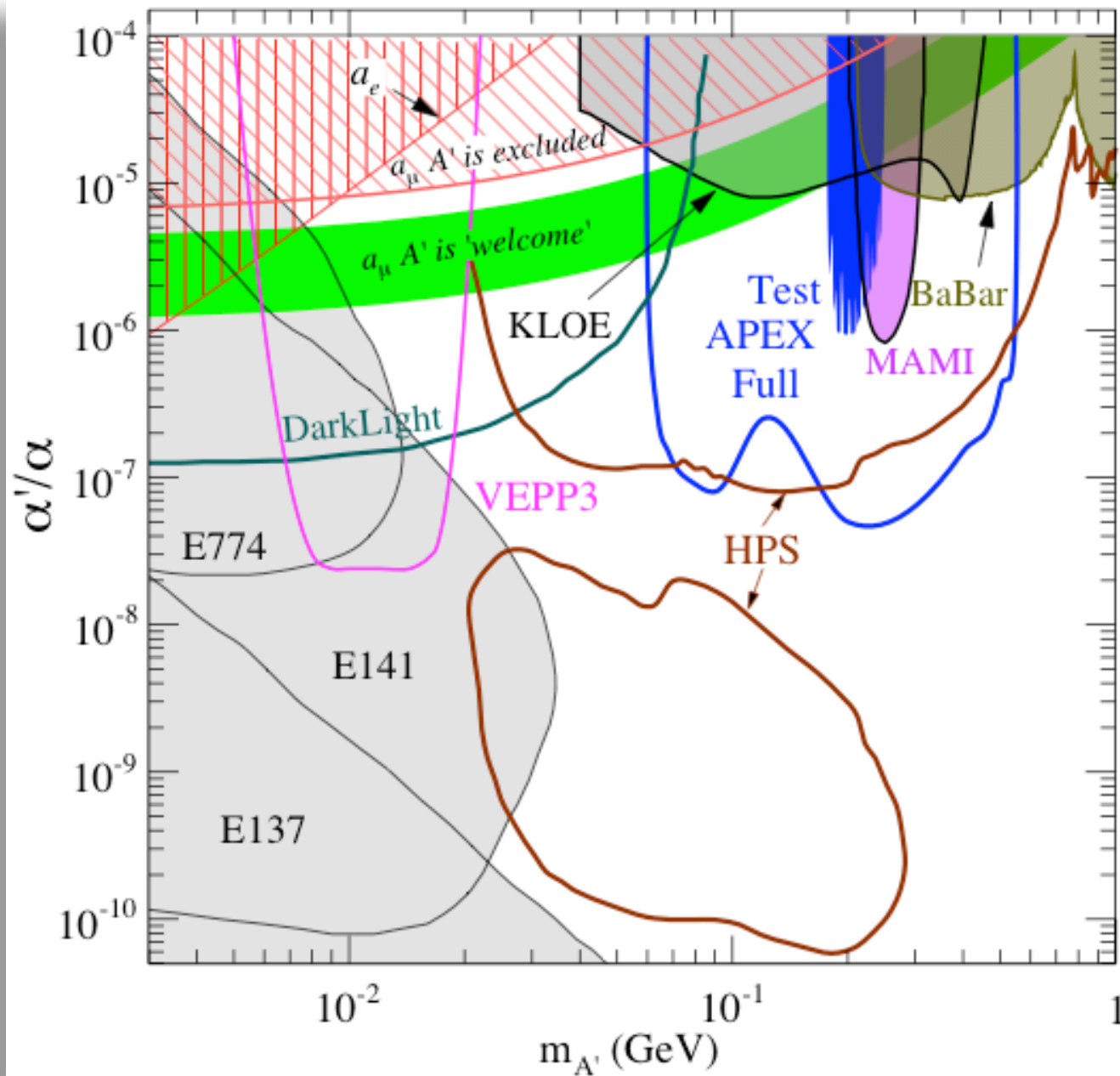

only $g-2 = a_e, a_\mu$,
 VEPP-3 and
 a portion
 of DarkLight
 are sensitive
 to “invisible”
 A' decay modes

Searches for a gauge boson A'

The recent meeting

Dark Forces at Accelerators

16th - 19th, October 2012
Laboratori Nazionali di Frascati, INFN
Frascati (Rome), Italy

The workshop will focus on experimental searches of new gauge bosons with masses in the MeV to GeV range. The connection of these studies to the search for dark matter will also be addressed.

International Advisory Committee

Franco Bedeschi (Pisa)
Achim Dengler (Mainz)
Manuel Drees (Bonn)
Robert Essig (Stony Brook)
Pierre Fayet (ENS)
Gino Isidori (INFN)
Jung Jaeckel (Durham)
Andrzej Kupsc (Uppsala)
Antonio Maierio (Padova)
Dimitri Ntirogiannis (Pavia)
Maxim Pospelov (Perimeter and Victoria)
Andreas Ringwald (DESY)
Natalia Toro (Perimeter)
LianTao Wang (Chicago)
Yangsheng Zheng (UCAS)

Local Organizing Committee

Fabio Bossi (INFN)
Maria Cristina D'Amato (secretary)
Antonio De Santis (Roma1)
Simone Giovannella (INFN)
Enrico Grazzani (Roma3)
Paolo Santangelo (INFN)
Barbara Sciaccia (INFN)

Contact: dark2012_loc@lists.infn.it

The part of Snowmass 2013
<http://www.snowmass2013.org/tiki-index.php?page=Intensity+Frontier>

The Intensity Frontier Workshop
at Argonne on 4/25-4/27, 2013

<http://www.lnf.infn.it/conference/dark>

Options for an e^+e^- experiment at low s

A “very” low energy, $s^{1/2} \sim 10\text{-}30$ MeV

- a) 5 MeV x 5 MeV head-head collider of $e^+e^- \Rightarrow \mathcal{L} \sim 10^{24}$
- b) Sliding beams of e^+e^- (250 MeV x 250 MeV) \Rightarrow
Project needs a specialized accelerator with two rings
- c) Our approach is a positron beam + atomic electrons

Luminosity of the colliders

from W. Panovsky's article in BEAM LINE

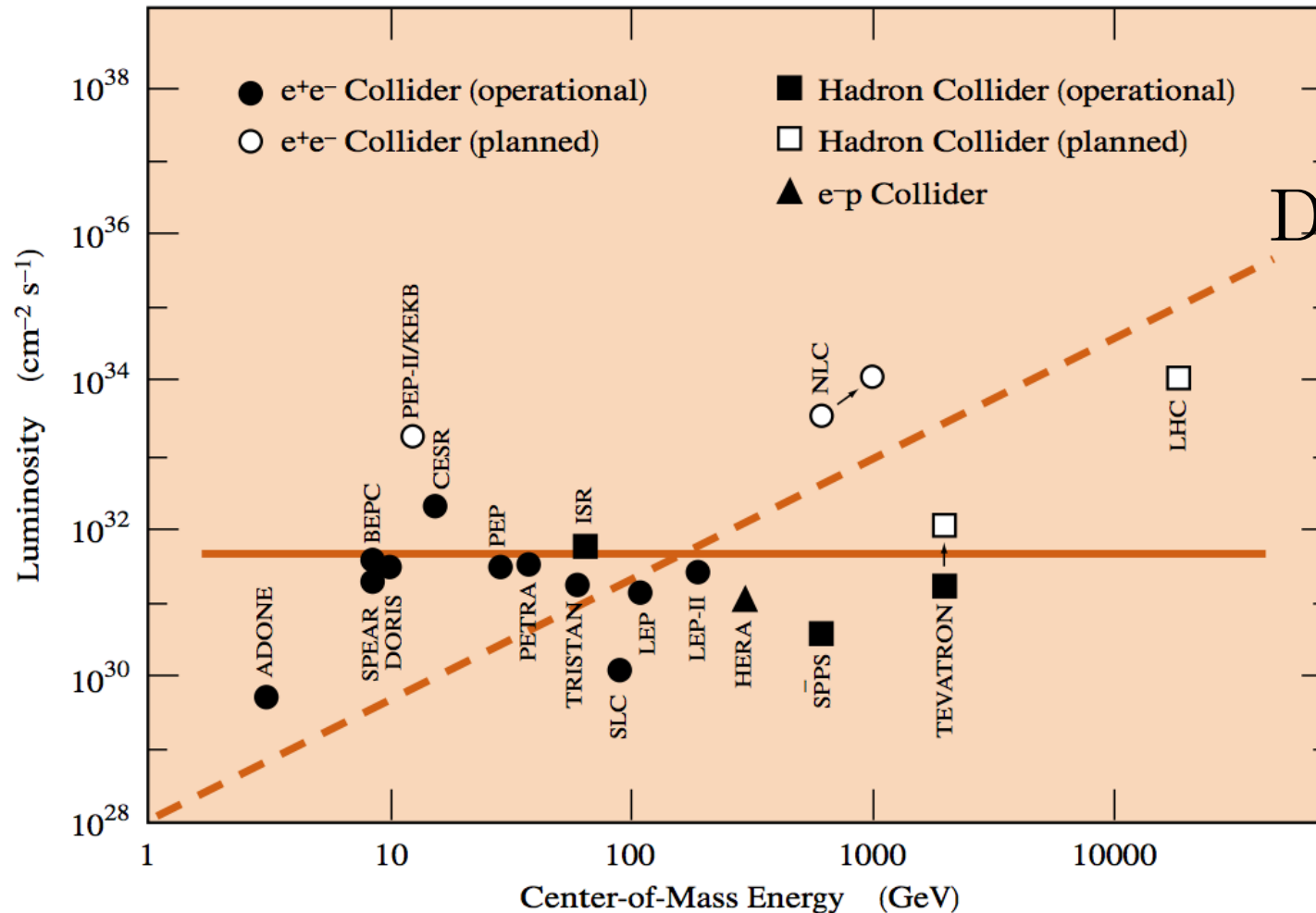

Dashed line is
 $\mathcal{L} \propto E_{cm}^2$

For $E_{cm} = 100$ MeV

$$\mathcal{L} \sim 10^{26} - 10^{29} \text{ cm}^{-2} / \text{s}$$

Luminosity using initial state radiation

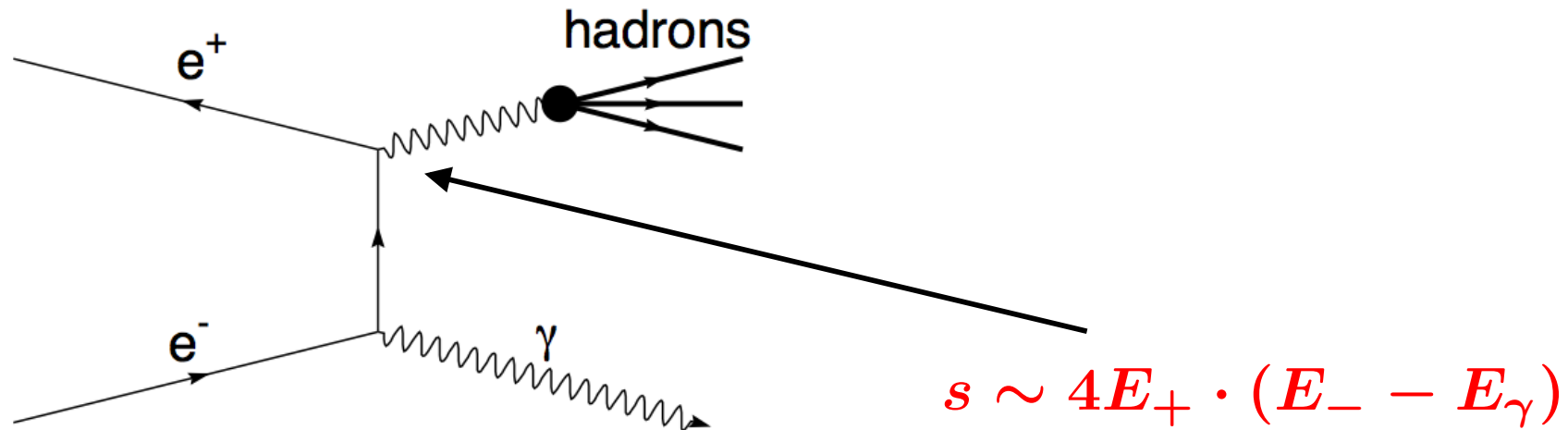

FIG. 2 The lowest-order Feynman diagram describing the initial state radiation process $e^+e^- \rightarrow \gamma + \text{hadrons}$.

$$\Delta \mathcal{L} \propto \mathcal{L} \times \frac{\Delta s}{s_{\max}}$$

when $s_{\max} = 10 \text{ GeV}$ and $\Delta s \sim 100 \text{ MeV}$ (APEX)

$$\Delta \mathcal{L} \sim 10^{-4} \mathcal{L}$$

BABAR search using initial state radiation

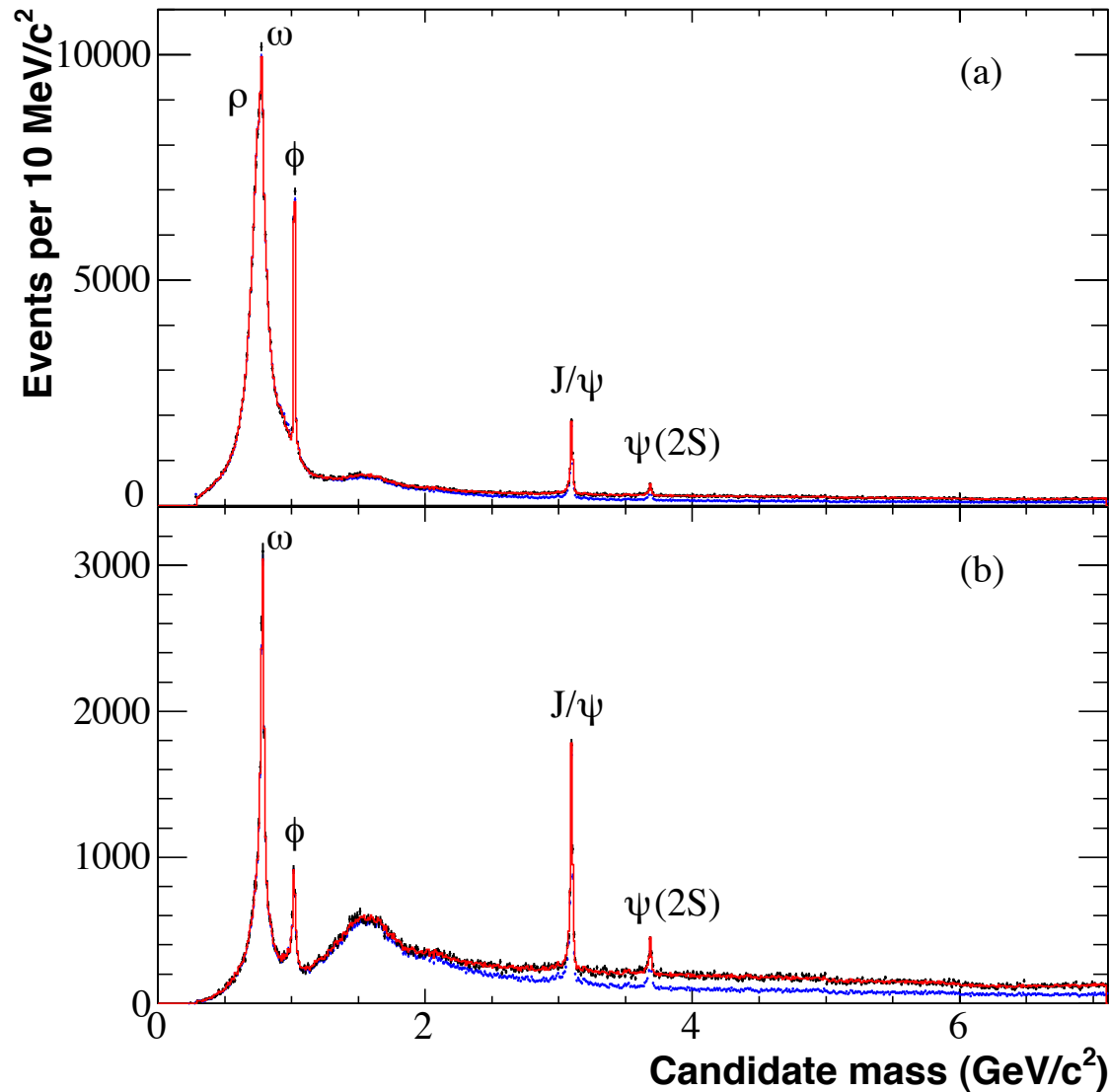

PRL 107, 221803 (2011)
Search for Hadronic
Decays of a
Light Higgs Boson
in the Radiative Decay

BABAR search using initial state radiation

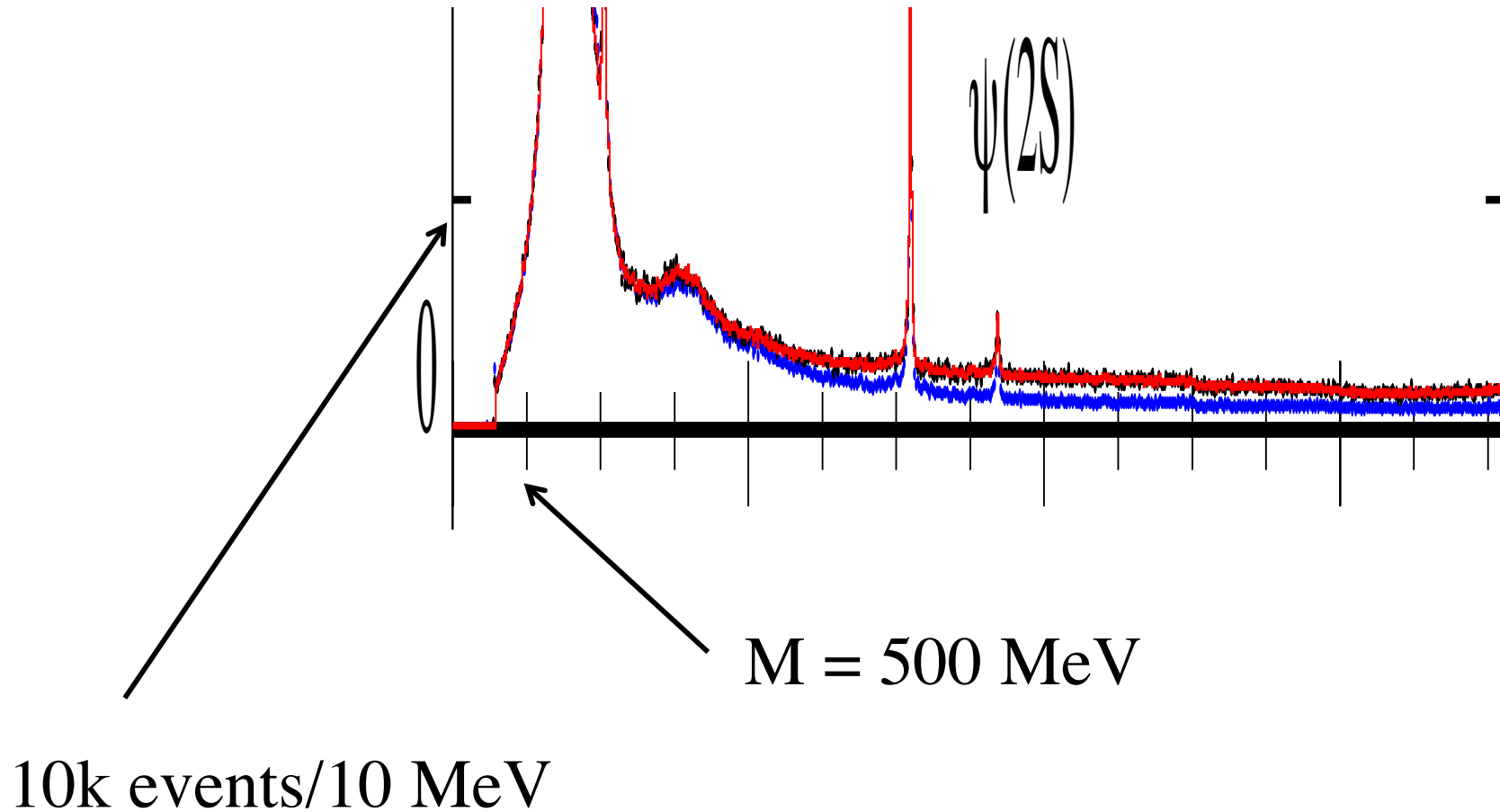

Where to find a positron beam?

- A beam of 25 nA 400 MeV was produced at Saclay in 1980s
- Beam of 1 μA was used for SLC (120 Hz)
- SLAC positron damping ring up to 1.2 GeV, 200 mA
- DORIS
- VEPP-3 energy of 0.5-2 GeV, 50 mA

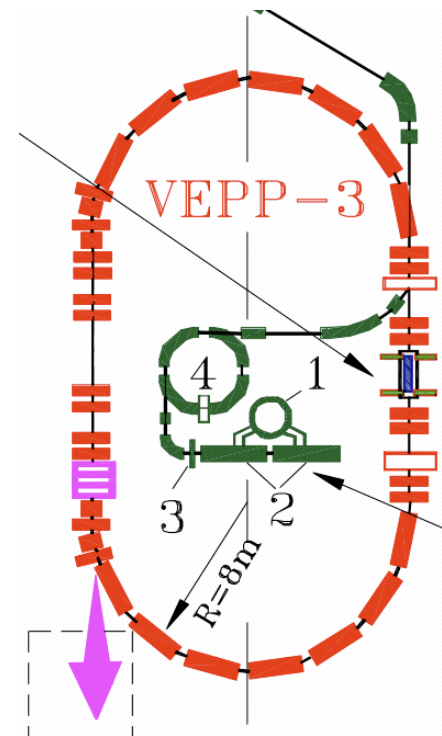
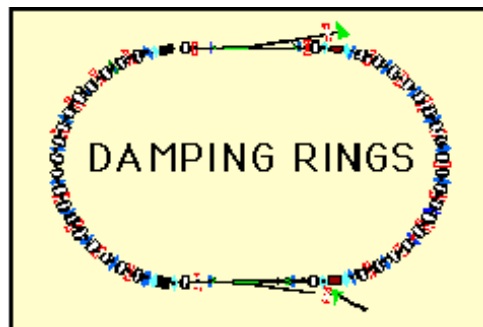

A few pictures of VEPP-3

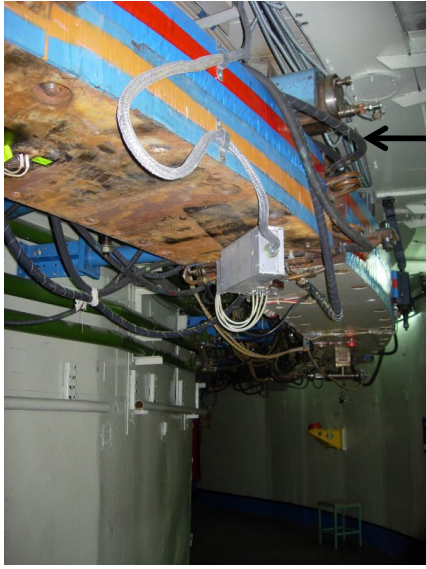

← Bend magnets
RF cavity
Injector
Fix target expt.

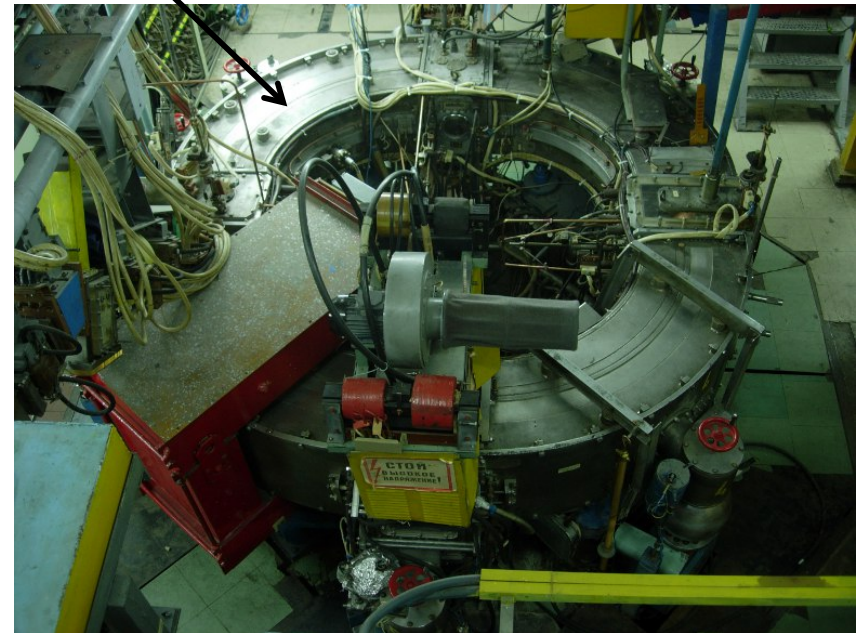
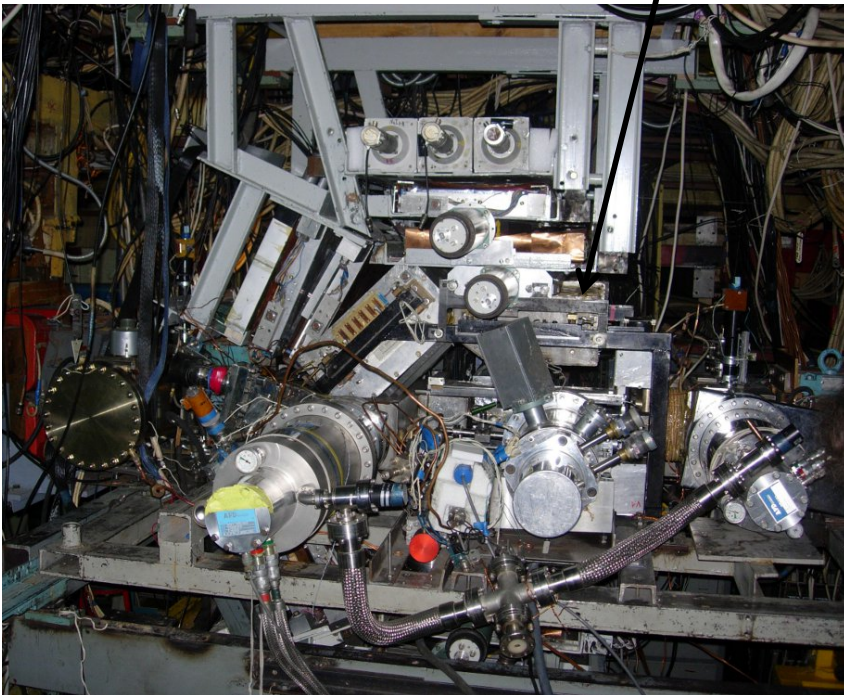
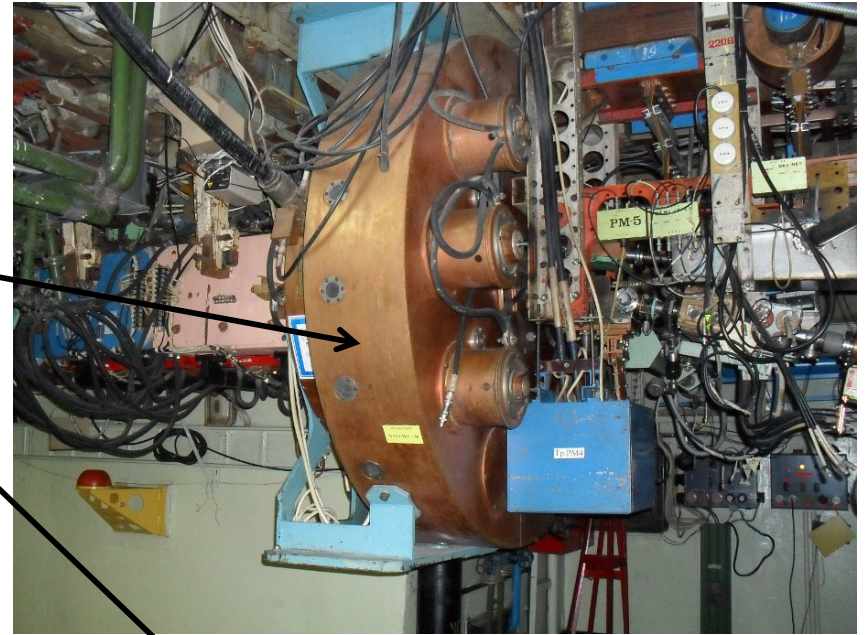

The photo-production processes

Basic QED: $e^+e^- \rightarrow \gamma\gamma$ (mono-energetic)
 Search for : $e^+e^- \rightarrow \gamma U$ (*peak below main*)
 Basic QED: $e^+Z \rightarrow \gamma$ (smooth brems.)

- Detect γ at fixed angle with the beam:
reconstruct the mass
- Variation with the angle:
control systematic
- Target Z
Hydrogen vs. ^{12}C

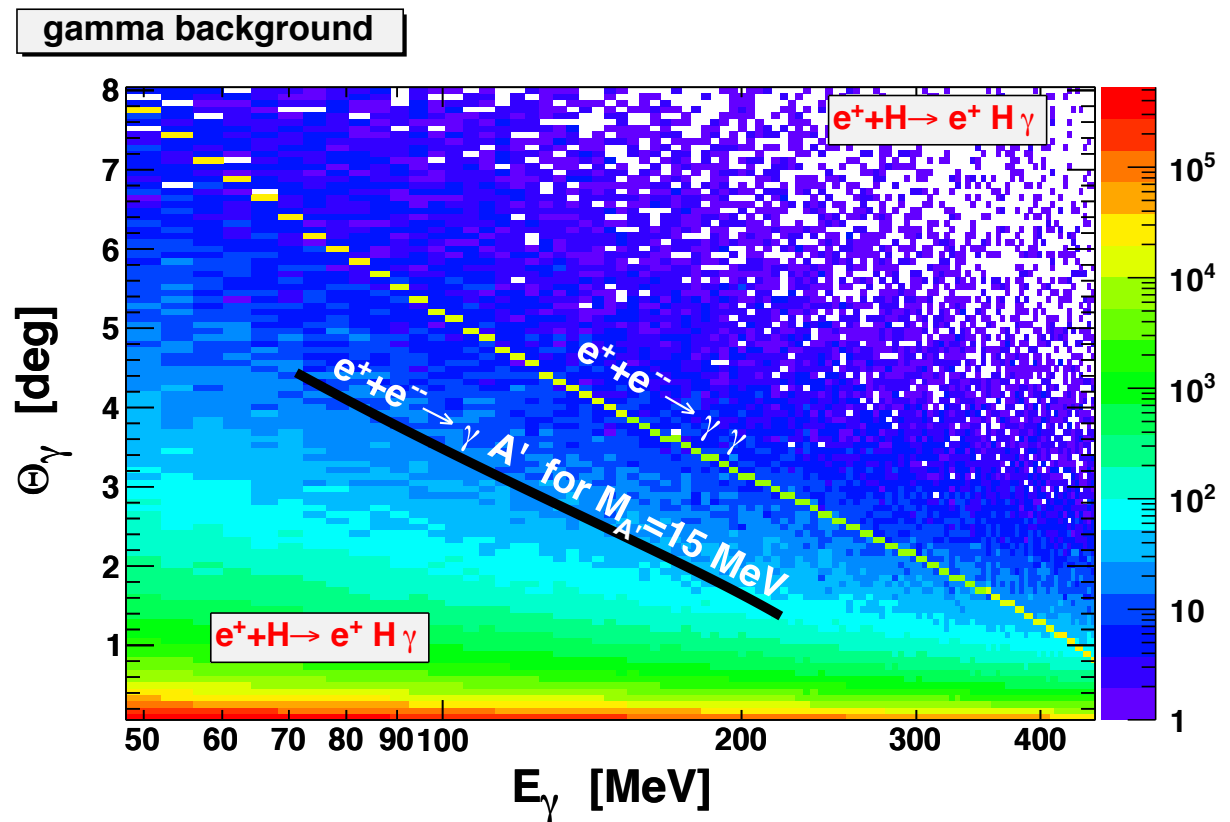

Concept of an experiment with a positron beam

Kinematics

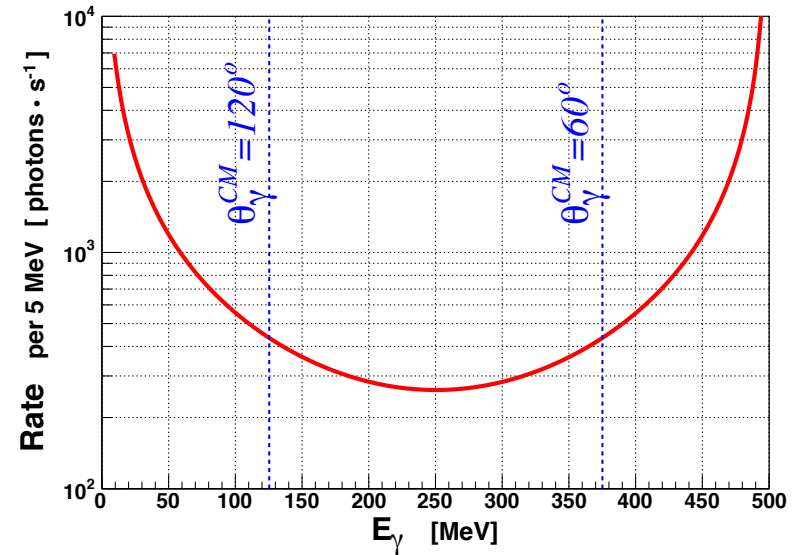
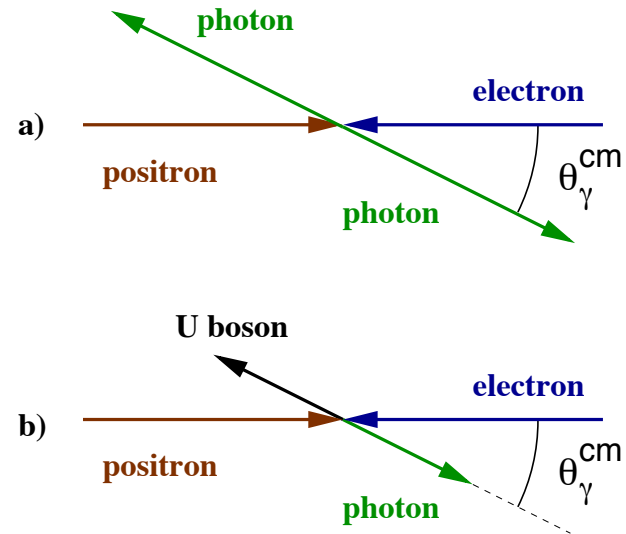
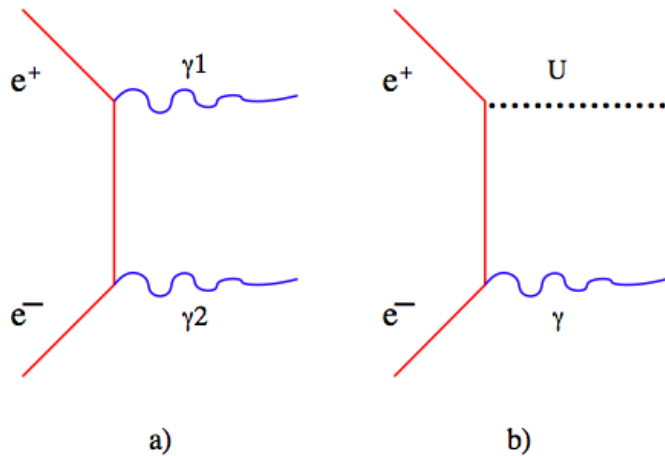

Concept of an experiment with a positron beam

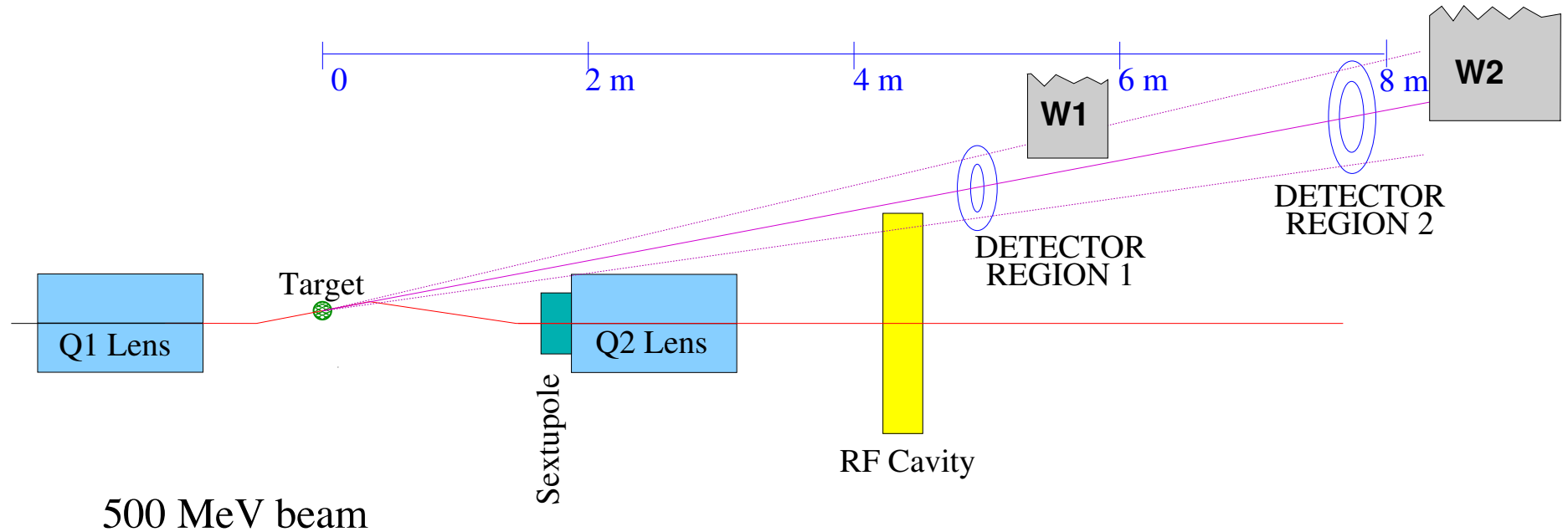

Proposal of an experiment at VEPP-3:
BW, Nikolenko, Rachek, arXiv:1207.5089

Experimental layout

$$\mathcal{L}_{e+e^-} \sim 10^{32}$$

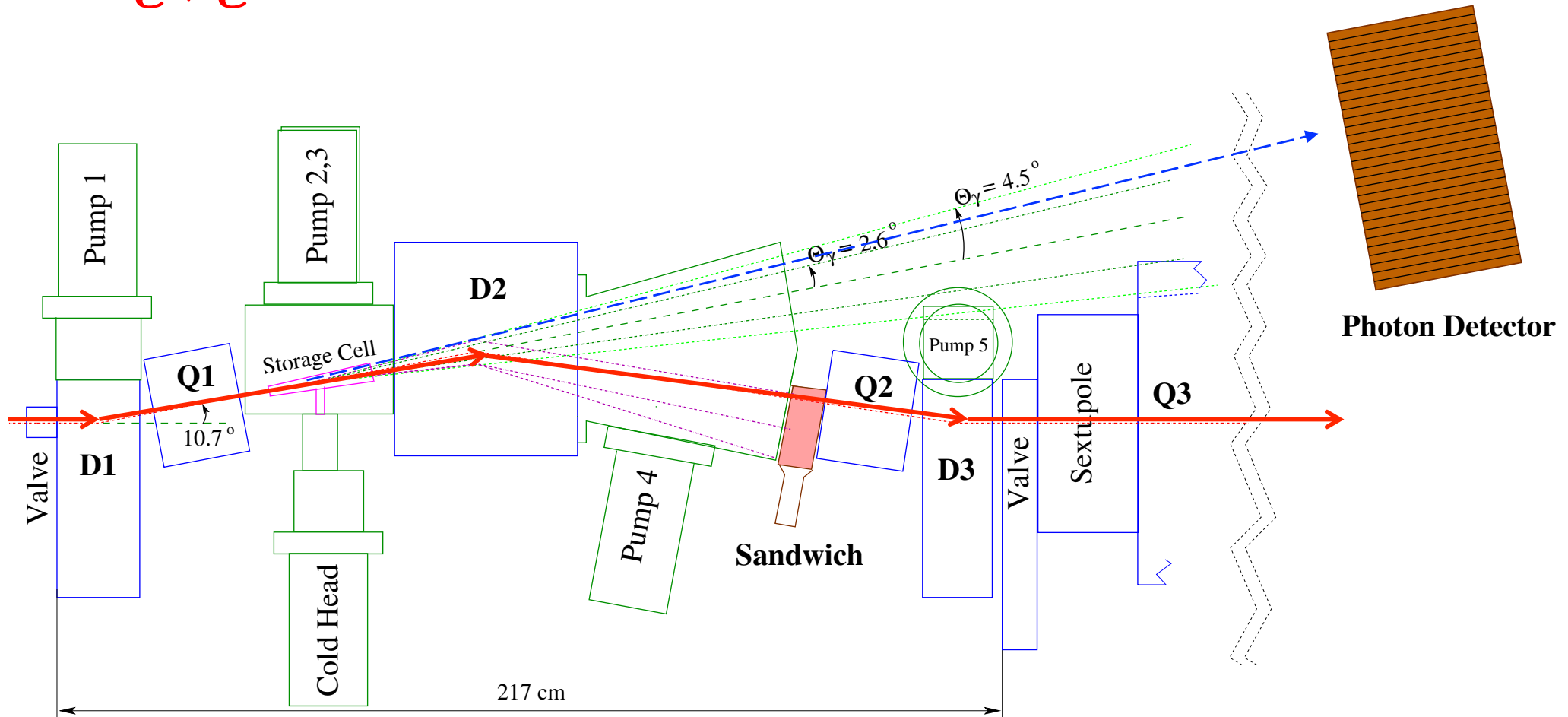

Positron beam on internal Hydrogen target

Physics background is the bremsstrahlung radiation

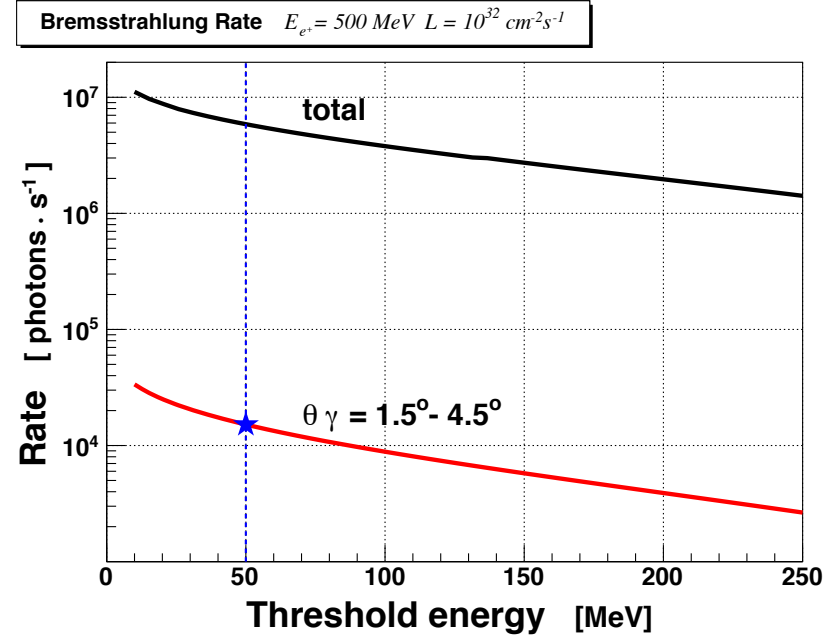

Anti-coincidence with the positron counters reduce QED background

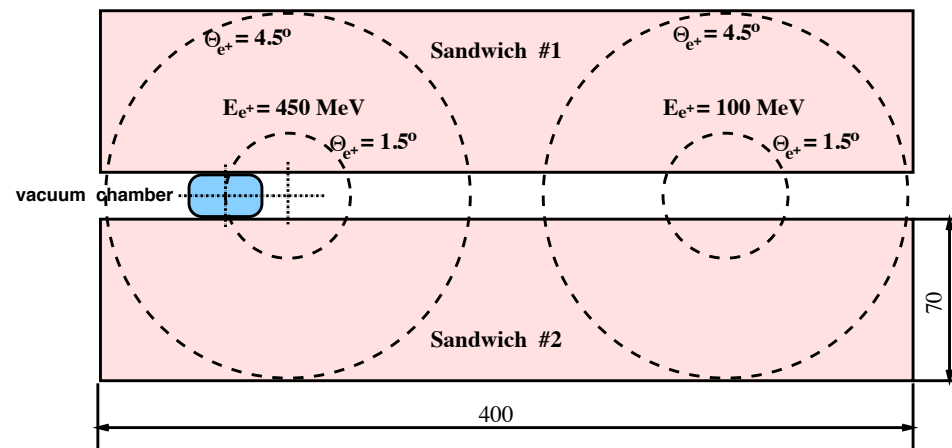

Positron beam on internal Hydrogen target

Projected event rate

A bump is $e^+e^- \rightarrow 2\gamma$

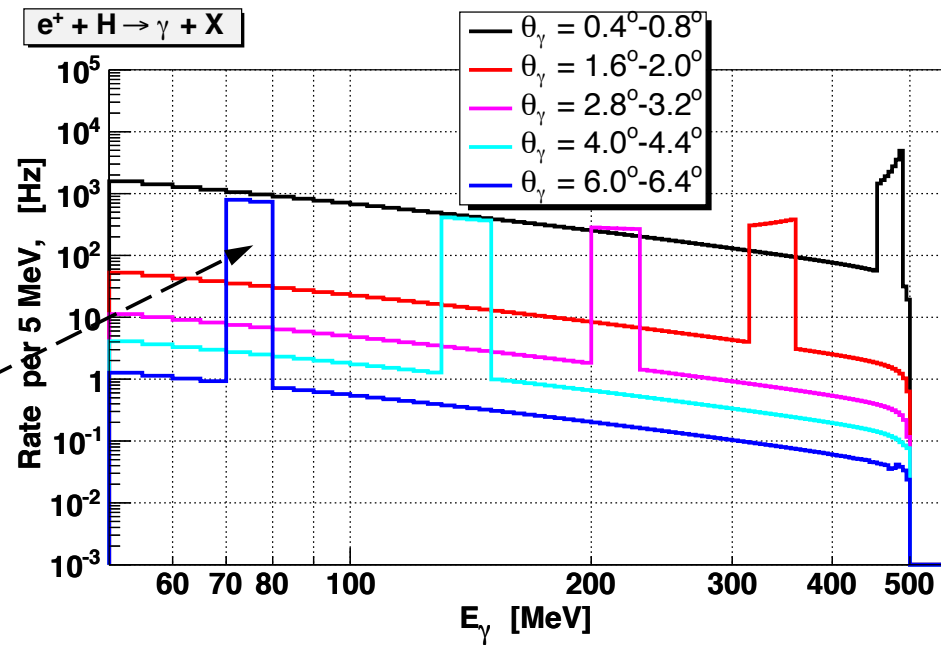

Projected for an electron beam for systematic check

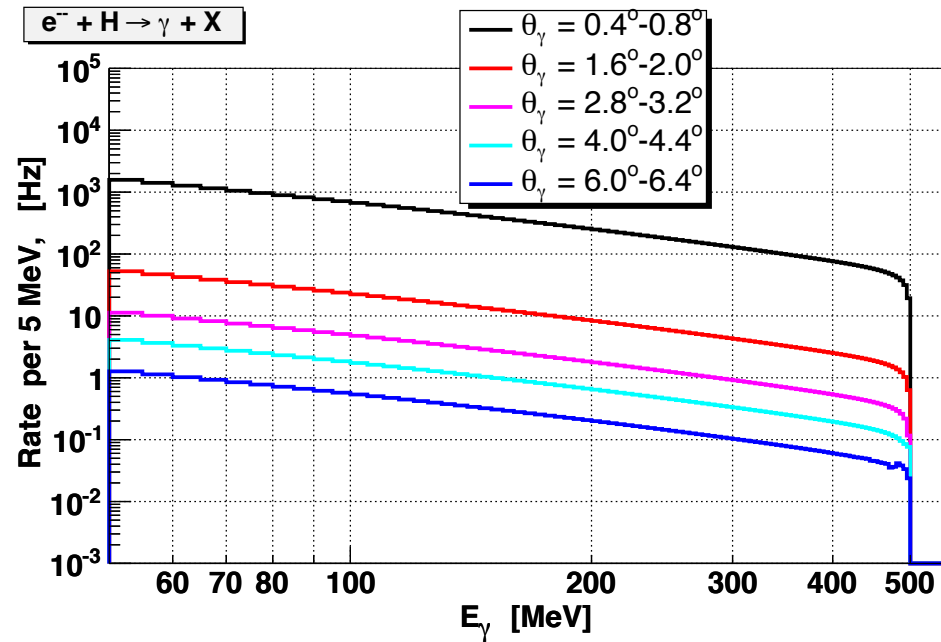

VEPP-3 operation during Two-Photon Exchange experiment

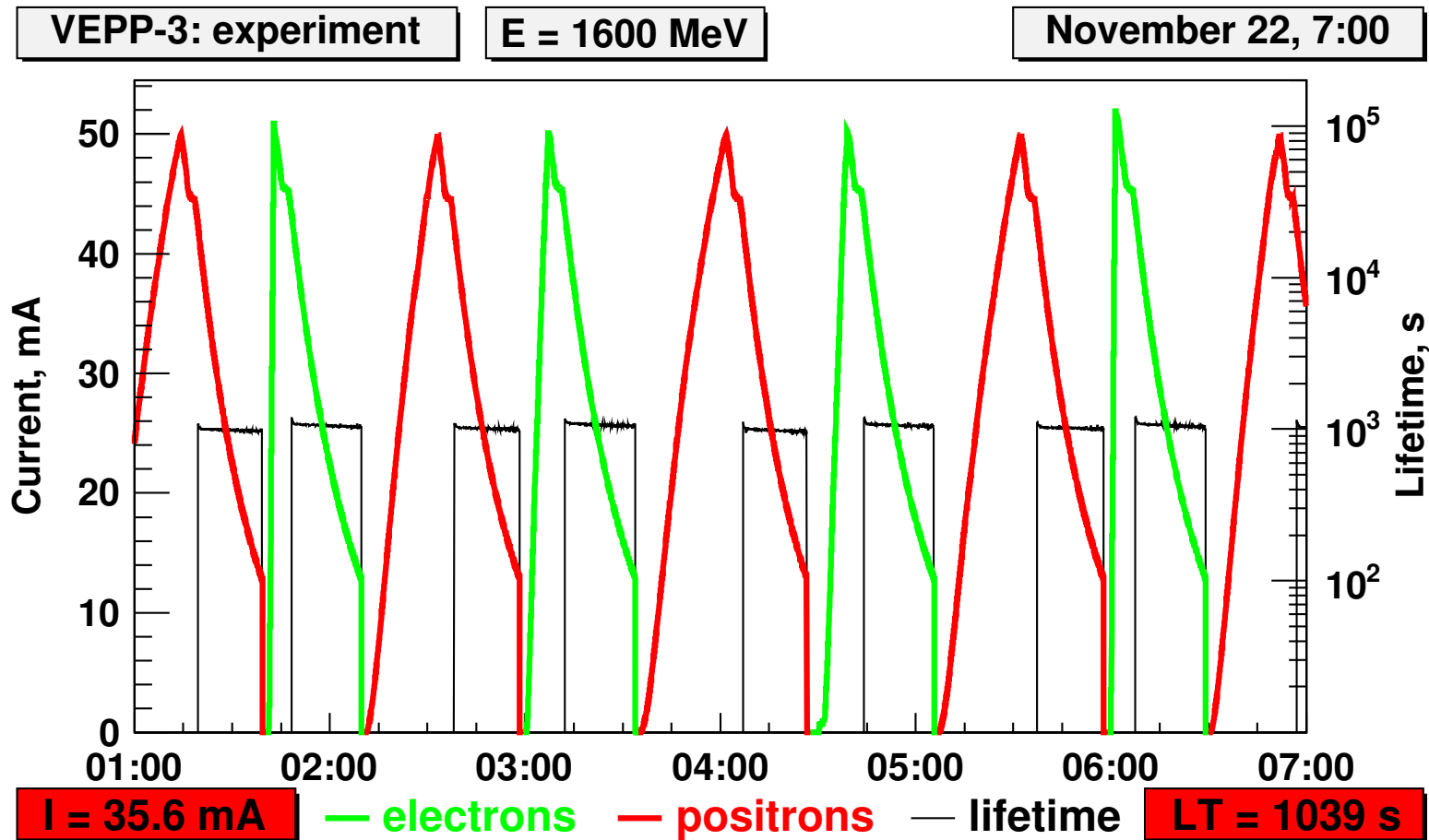

Photon detector

The photon detector can be placed at a distance of between 4 m and 8 m from the target. The requirements for the detector are:

- Energy resolution on the level of $\sigma_E/E = 5\%$ for photons with energy $E_\gamma = 100 - 450$ MeV.
- Angular resolution on a level of 0.1° .
- Angular acceptance as defined by a requirement to detect both photons from two-photon annihilation:
 - in ϕ : either total 2π , or two symmetrical sectors, e.g. (ϕ_1, ϕ_2) and $(\phi_1 + \pi, \phi_2 + \pi)$;
 - in θ : symmetrical range in θ_γ^{CM} around 90° , e.g. $\theta_\gamma^{CM} = 60^\circ - 120^\circ$, which corresponds to $\theta_\gamma^{LAB} = 1.5^\circ - 4.5^\circ$.
- The detector should be able to sustain a modest photon rate of several hundred kHz over its whole area.

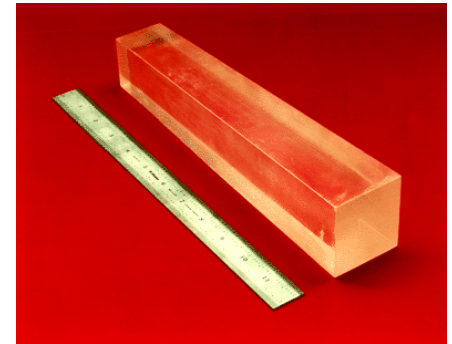

Potential source of crystals:

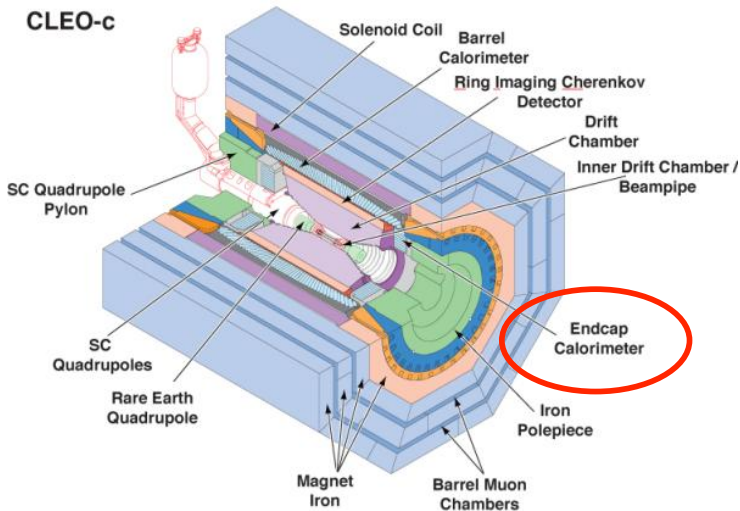

The electromagnetic calorimeter of the CLEO-II detector³⁵ consists of 8000 CsI(Tl) crystals of $5 \times 5 \times 30$ cm³ size ($16.2X_0$). It is used to measure electron and photon energy in a wide range; therefore, a direct measurement of its performance at a photon energy of interest for the proposed experiment is available:

$$\delta E/E = 3.8\% \quad \text{and} \quad \delta x = 12 \text{ mm} \quad \text{for} \quad E_\gamma = 180 \text{ MeV}$$

One can see that in the energy range of the proposed experiment, a CsI(Tl)-based calorimeter provides better energy resolution but a worse spatial one than that based on PbWO₄-crystals. Therefore, the CsI(Tl)-calorimeter must be placed as far as possible from the target, i.e. about 8 m. In this case it would take about 800 crystals to cover the required angular range.

Internal target for Two-Photon Exchange experiment

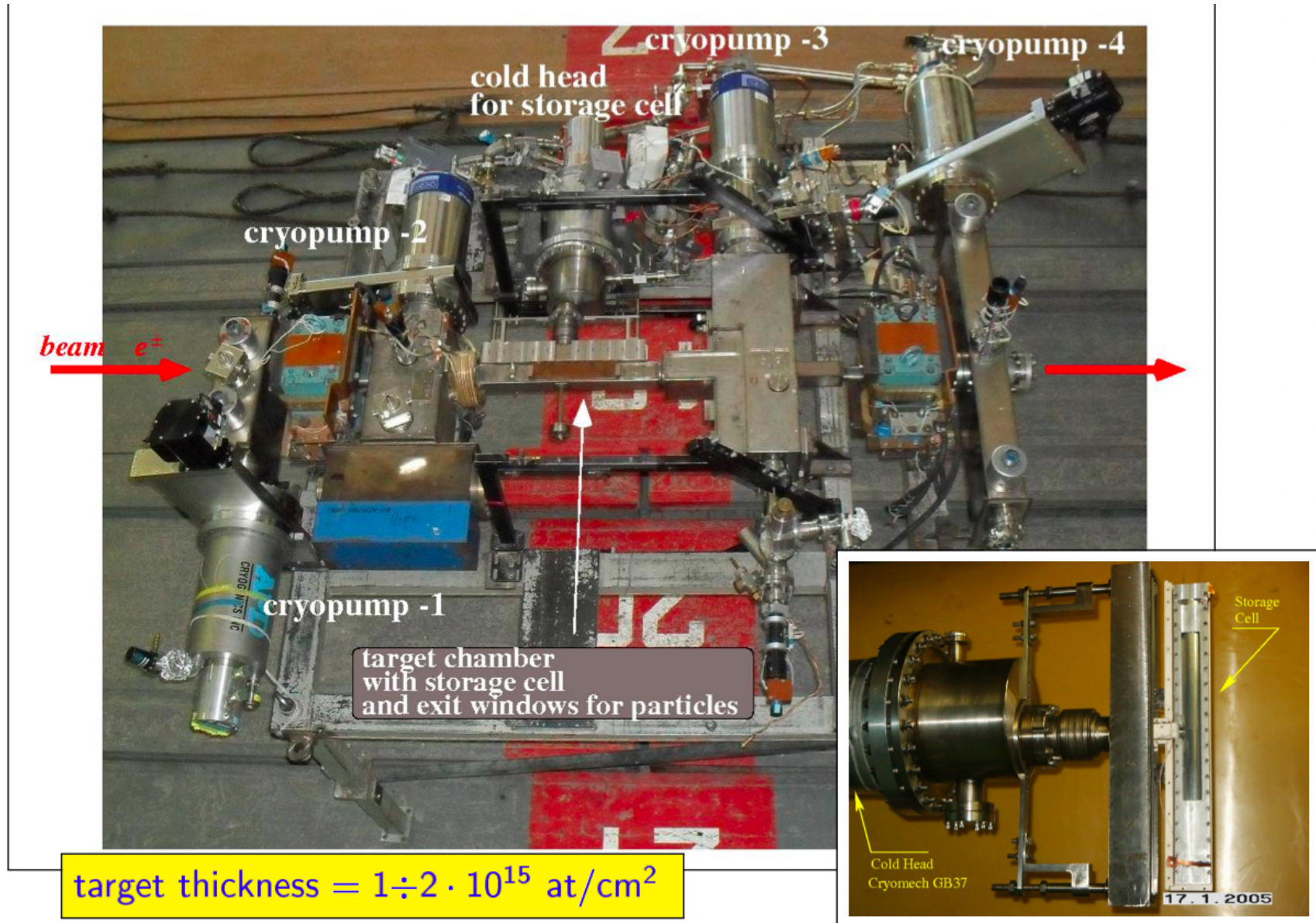

Kinematical correlation

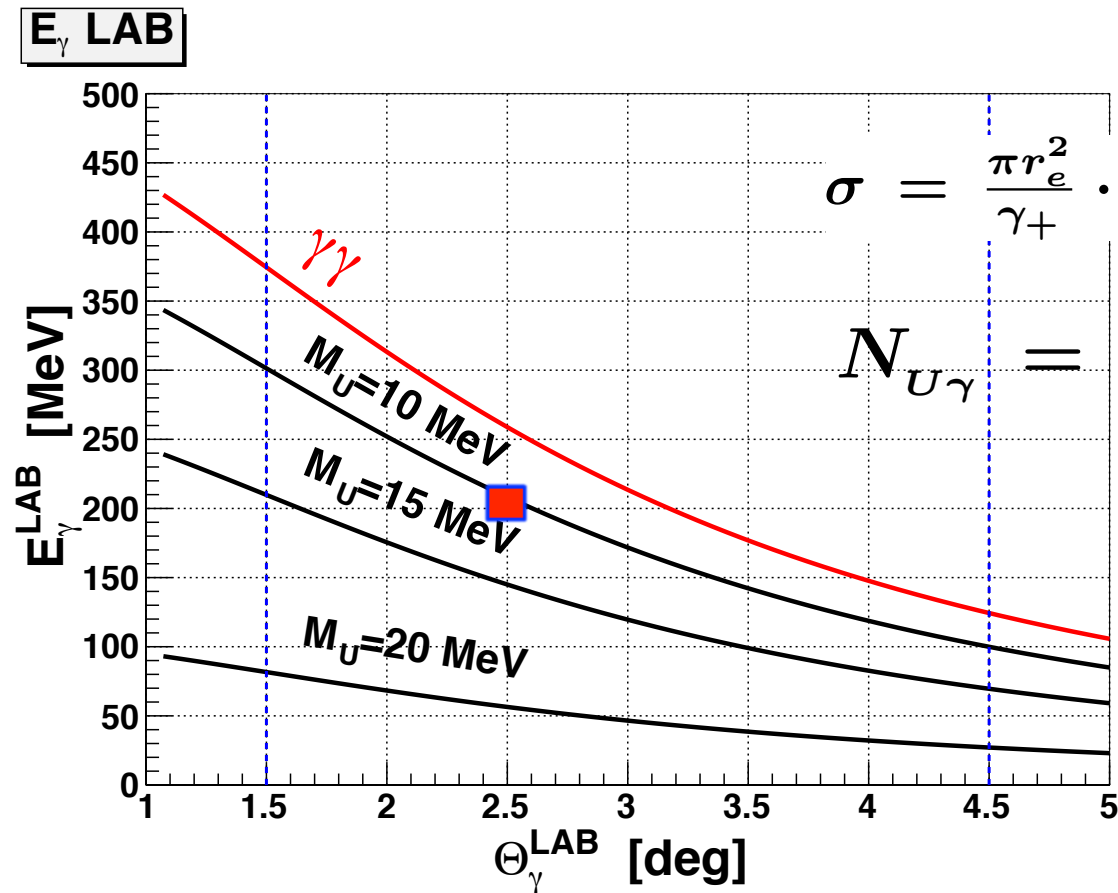

$$\sigma = \frac{\pi r_e^2}{\gamma_+} \cdot (\ln 2\gamma_+ - 1)$$

$$N_{U\gamma} = 2 \frac{\alpha'}{\alpha} \cdot N_{\gamma\gamma}$$

$$E_{\gamma(A'\gamma)}^{lab} = E_{\gamma(\gamma\gamma)}^{lab} \cdot (1 - M_{A'}^2/s)$$

The U(or A') mass resolution $\sim 3\%$

Projected sensitivity in the parameter space

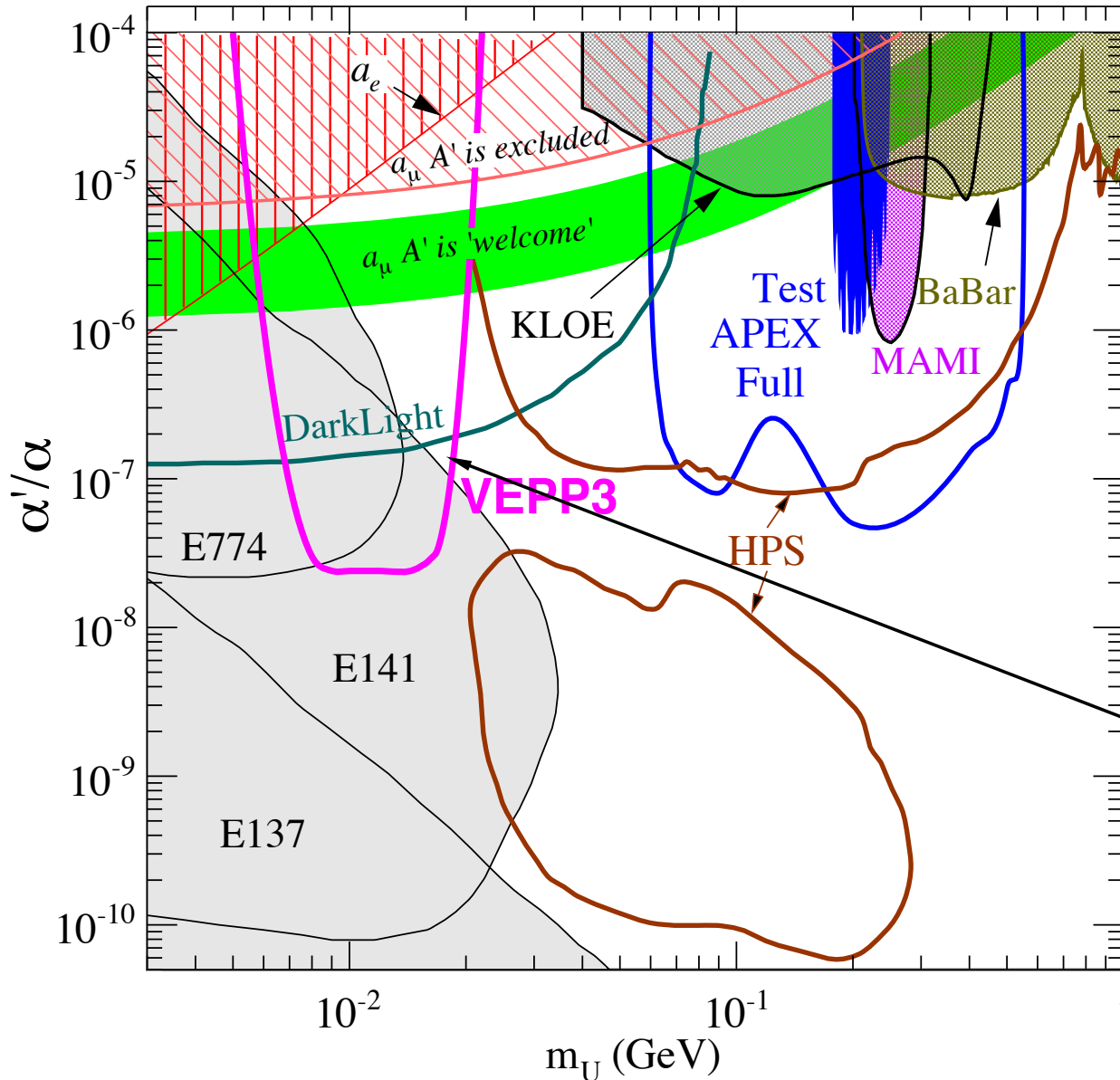

Projected sensitivity
for the VEPP-3
measurement at
 $L_{ep} = 10^{32} \text{ cm}^{-2}/\text{s}$
(aver. current of 25 mA)
in the six-month run

Projected sensitivity in the parameter space

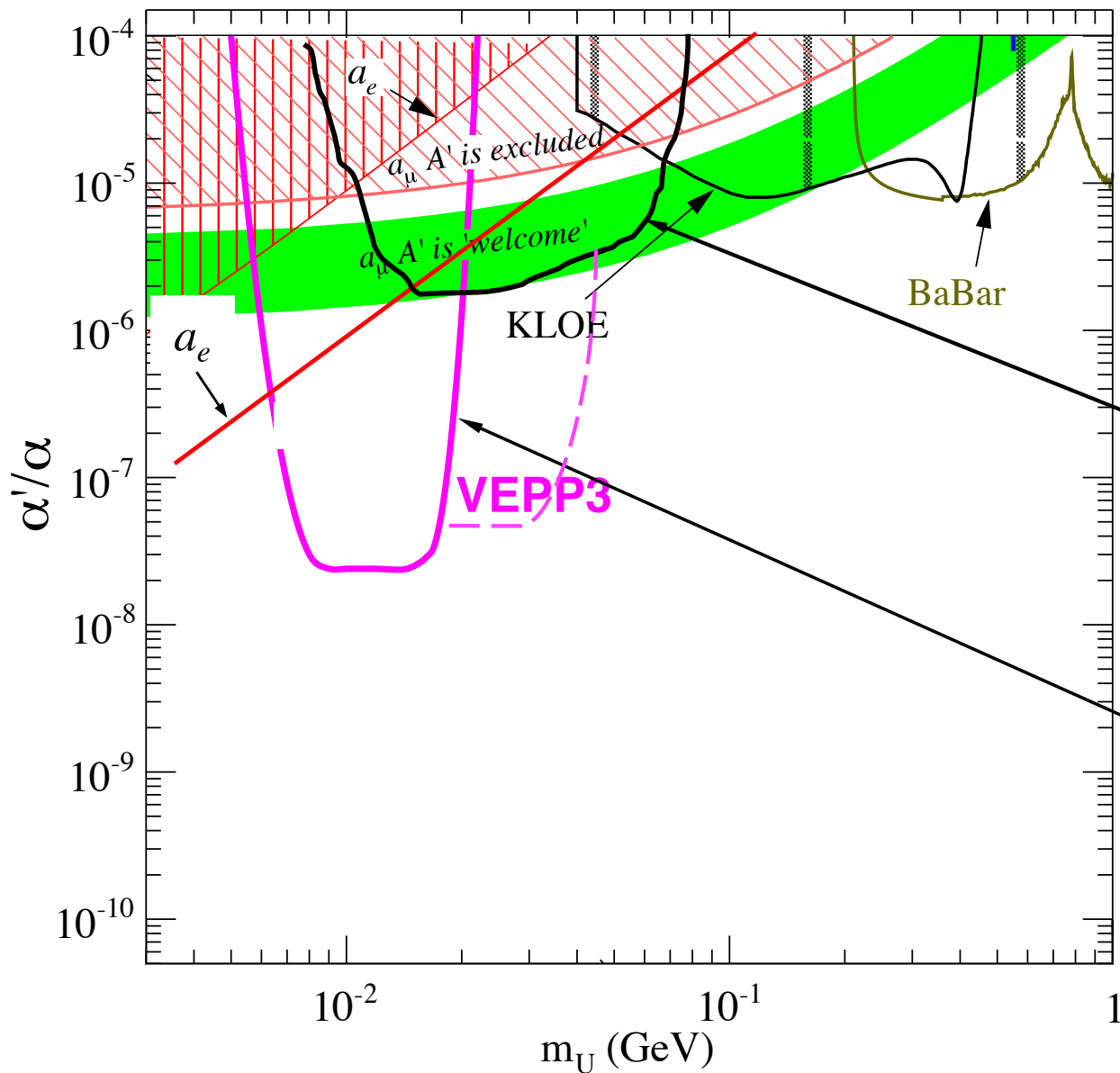

These searches
are sensitive
to “invisible”

DarkLight (to “invisible”)
Y. Kahn, J. Thaler,
arXiv:1209.0777

Projected sensitivity
for VEPP-3 (at 500 MeV)
measurement at
 $L_{ep} = 10^{32} \text{ cm}^{-2}/\text{s}$
(aver. current of 25 mA)
in the six-month run

- - - with 5 GeV beam

Summary

- Search for the A'/U boson in the photon recoil spectra is possible using a positron beam and internal hydrogen target in the 500 MeV storage ring.
- Available luminosity ($\sim 10^{32}$) allows a 10-100+ improvement over the $(g-2)$ limit in mass range 7-15 MeV. The range could be extended to 50 MeV with 5 GeV beam.
- Segmented high-resolution electromagnetic calorimeter is a key new part of the setup.