

## BEAM PIPE HOM ABSORBER FOR SRF CAVITIES\*

M. Neubauer, R. Sah, A. Dudas, Muons, Inc., Batavia, IL  
 G. Hoffstaetter, H. Padamsee, M. Liepe, and V. Shemelin, Cornell University, Ithaca, NY  
 K. Ko, L. Xiao, and C. Ng, SLAC, Menlo Park, CA

### Abstract

Superconducting RF (SRF) systems typically contain resonances at unwanted frequencies, or higher order modes (HOM). For storage ring and linac applications, these higher modes must be damped by absorbing them in ferrite and other lossy ceramic materials. Typically, these absorbers are brazed to substrates that are often located in the drift tubes adjacent to the SRF cavity. These HOM absorbers must have broadband microwave loss characteristics and must be thermally and mechanically robust, but the ferrites and their attachments are weak under tensile and thermal stresses and tend to crack. Based on prior work on HOM loads for high current storage rings and for an ERL injector cryomodule, a HOM absorber with improved materials and design is being developed for high-gradient SRF systems. This work will use novel construction techniques (without brazing) to maintain the ferrite in mechanical compression. Attachment techniques to the metal substrates will include process techniques for fully-compressed ferrite rings. Prototype structures will be fabricated and tested for mechanical strength under thermal cycling conditions.

### INTRODUCTION

We are developing techniques for designing and constructing beam pipe HOM absorbers using ferrite materials. Reliable beam pipe HOM loads must meet six critical performance requirements. They must:

1. Have an RF design and use materials that damp the HOMs at cryogenic temperatures,
2. Have a good mechanical design to remove the heat from the absorbed RF power,
3. Withstand the temperature stresses,
4. Have low outgassing rates for UHV compatibility,
5. Have material strength such that there is no dust, and
6. Have some DC conductivity to prevent the buildup of surface charge.

The items related to the material requirements have been studied quite extensively by our collaborators at Cornell, and several materials have been found that meet the above requirements [1]. More recently that list has been reduced as further studies have revealed the degree to which these materials would lose their conductivity and be prone to the accumulation of surface charge at cryogenic temperatures [2].

Mechanical designs of HOM loads have addressed issues including various methods for attaching the HOM

loads materials to the ID and/or OD of cylinders, and the sintering of the lossy material inside a cylinder for an “in situ” construction process.

All of these processes have worked to some degree, but their performance under the load stress has more often than not ended in failure. These failures usually consist of (1) the failure of the bond between the lossy material and the metal support structure or (2) the fracture of the lossy material itself. These fractures of the lossy material are caused primarily by the low tensile strength of the material.

### TECHNICAL APPROACH

This new HOM load design features the use of special assembly procedures to produce absorber rings captured in compression. The load will be made up of four Single Pak Assemblies (SPAs), each assembly consisting of a 1” long absorber cylinder that is held in compression by a copper composite cylinder. Several SPAs will be welded or brazed together to form a Multi Pak Assembly (MPA). Figure 2 shows the HOM Load made up of such an MPA.

By appropriately selecting the copper alloy, the thermal expansion of the composite can be “matched” to the thermal expansion of the absorber material. Thermal conductivity is also a selection criterion for this selection process. (See Figure 1 below for data on a copper-tungsten composite material.) SPA parts will be machined to close tolerances, and then the SPA will be assembled after heating the metal composite while cooling the ferrite or other lossy material.

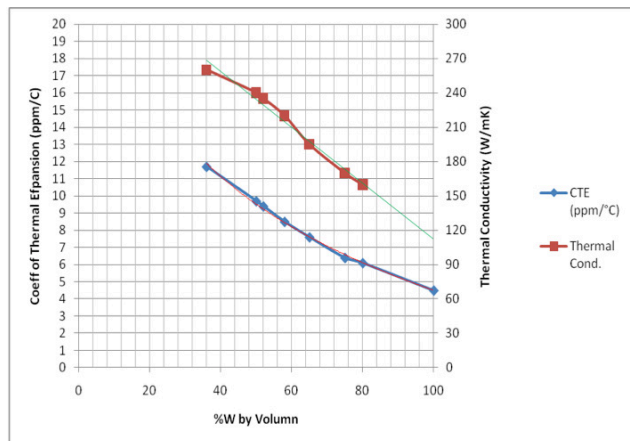

Figure 1: Thermal Expansion of Copper-Tungsten Composite.

The MPA end design allows for axial motion of the MPA within the vacuum envelop of the Load. The design consists of a “folded” ring of material similar to “finger

\* Supported in part by USDOE Contract No. DE-AC05-84-ER-40150 and SBIR Grant DE-SC0002733

stock” which is firmly attached to both the MPA and the vacuum envelope, and flexes with the thermal motion of the MPA. The advantage of this design is two-fold: there is no “rubbing” to create small particles, and the ring prevents RF from entering the region between the MPA and the bellows of the vacuum envelope.

There are a number of advantages of such a MPA absorber design. First, different absorber materials can be used in the same MPA, so that the range of absorbed frequencies can be greater. Second, the absorber and copper composite are not brazed together, so the differential thermal expansion does not damage the joint. However, due to the compressive contact the thermal conductivity across the joint remains good. Third, the SPAs are designed so that the MPA fully traps the absorber within the assembly, so that even if the compression joint did not function perfectly, the absorber will not move. Fourth, the end design of the MPA is such that no absorber material need be in the region adjacent to the bellows.

Figure 2 is an early conceptual drawing of this HOM Absorber design.

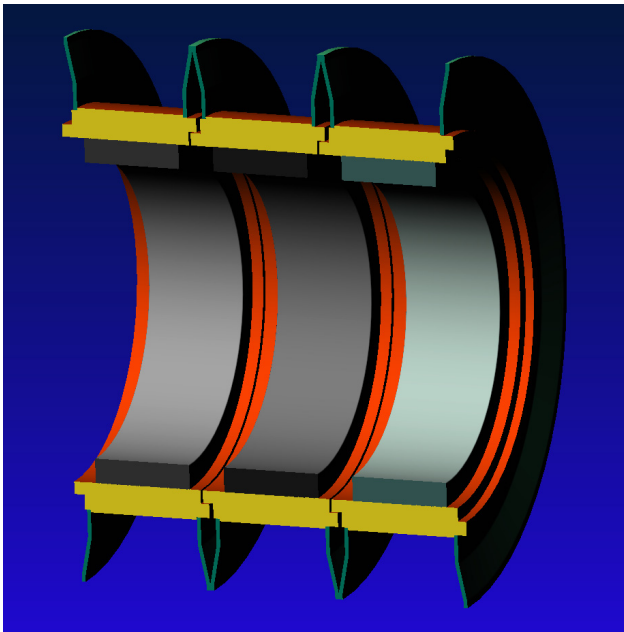

Figure 2: Conceptual drawing of Beam Pipe HOM loads

### Initial Experiments on the Assembly Process

One-inch-long cylinders of ferrite were selected for the initial experimental investigations. The manufacturer of the ferrite material also considered this to be a reasonable dimension for these experiments.

The assembly process was based upon taking advantage of the differential expansion of the ferrite and copper composite. We used two different processes: (1) the copper and ferrite were both raised to an elevated temperature, such that the copper ID expanded to a larger value than the ferrite OD, and (2) the copper was raised to a moderate temperature and the ferrite cooled in LN at the beginning of a room temperature assembly process. The

mechanical design of the copper compression ring assembly included a means for assuring the ring of ferrite would be guided into the copper to form the interference fit. Any tilt of the ferrite relative to the copper would have created an ellipsoid, and the insertion process would have ended in failure. See Figure 3.

The linear taper at the top of the copper cylinder was used to guide the insertion of the ferrite cylinder and was later removed in a machining process. The purpose of the linear taper at the bottom of the copper cylinder was to minimize edge stresses on the ferrite when the copper shrank down to form the interference fit at room temperature and also during further cool down to operating temperatures.

After the insertion process, the assembly was machined to remove the sleeve taper, and the ends prepared such that several assemblies could be joined together to form a multi pack of ferrites as shown in Figure 2.

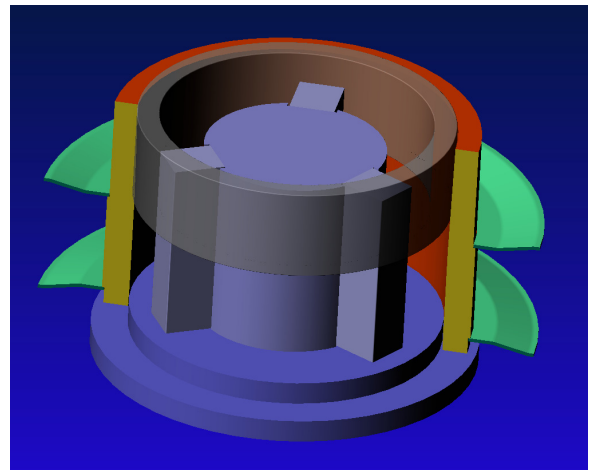

Figure 3: Pictorial representation of the use of the assembly fixture. (Ferrite ID is 3” with a nominal 0.030” wall.)

The room temperature assembly process included cooling the ferrite toroid to  $-200^{\circ}\text{C}$ , and heating the copper to  $100^{\circ}\text{C}$ , then using a machine shop milling machine to align the ferrite with an insertion tool as shown in Figure 3. The guiding end of the assembly provided the necessary centering to make a smooth insertion.

### Results of the Assembly Process

Table 1: Results of the assembly process for a designed interference fit at room temperature.

Run #	Type of Run	Interference fit on diameters	Results
1	Hot	.010"	failed
2	Hot	.005"	failed
3	Hot	.010"	success
4	Hot	.0075"	success
5	Hot	.005"	success
6	Room Temp	0.005"	success
7	Room Temp	0.005"	success
8	Room Temp	.0075"	failed

As shown in Table 1, the first two hot runs were failures. We adjusted the way we used the fixture and the next three runs were successful at all interference fits we had designed for. The only problem with the hot run was the inadequate control of the atmosphere which created unwanted oxidation.

The room temperature runs were a success until we attempted too much of an interference fit. As shown in the table, the .0075 interference fit resulted in failure as the ferrite got stuck half way into the insertion process.

In addition, a glass coating is being developed for the ferrite. The goal of this coating is to create the necessary losses to prevent the ferrites from charging up during beam operation and still allow the RF fields from the HOMs to penetrate through to the ferrite.

### Future Experiments

Initial testing of the compression concept was carried out earlier, where it was shown that such a technique is feasible and relatively easy to accomplish.

In future experiments, we shall investigate CoorsTek SC-DSG (SC-35) material from Cornell. We shall slice this cylinder into ~1" long pieces, and these pieces will be inserted, as described above, into copper composite cylinders. One possible technique involves slicing the inner surface of the alloy cylinders into small posts to further act as a buffer for the differing thermal expansion characteristics. Mechanical tests of the joint will be performed at room and LN2 temperatures.

As was discussed in a number of papers in the 2010 HOM Load Workshop at Cornell, there are a number of materials under consideration for HOM Load absorbers. One leading candidate is CoorsTek SC-DSG (SC-35), but other materials are also being considered and evaluated. Cornell has recently tested Ceralloy CA-137 (supplied by Frank Marhauser of JLab) using the techniques discussed in paper WA4 of the Cornell Workshop[3]. Frank Marhauser's presentation TA6 at the Cornell Workshop is also a valuable resource for possible materials for this use[4].

## NUMERICAL SIMULATIONS

Finite-element simulation codes will be used to support this development project. The code ACE3P is being used to carry out computer simulations in support of this HOM Absorber project. It is being used to simulate a scaled-down HOM Absorber that can be assembled in the beam pipe of a 1.3-GHz Cornell cryomodule. ACE3P is a suite of parallel higher-order finite-element-based electromagnetic codes developed at SLAC under laboratory and SciDAC support[5]. The modules of ACE3P cover a wide range of accelerator applications, including cavity design, wakefield computations, multipacting calculations, RF gun modeling, and multi-physics analysis that includes thermal and mechanical effects. This comprehensive set of simulation capabilities is being made accessible to the accelerator community through the SLAC Code Workshop series to help advance

accelerator science and accelerator development projects across the DOE SC complex.

The geometry model for the 7-cell ERL cavity is shown in Fig. 4. To suppress the BBU, the most dangerous higher-order modes (HOM) have to be effectively damped by RF loads in the cavity beam pipes. Preliminary results using the Omega3P module within ACE3P are shown in Fig. 5, for all the dipole modes up to 3.5 GHz. Because of the presence of the input coupler, there are 14 dipole modes in each dipole band, and the effects of those with high loaded Q on the BBU will be studied to assess the effectiveness of the HOM Absorber.

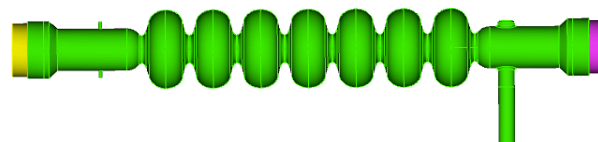

Figure 4: Geometry model for the Cornell 7-cell 1.3 GHz ERL cavity

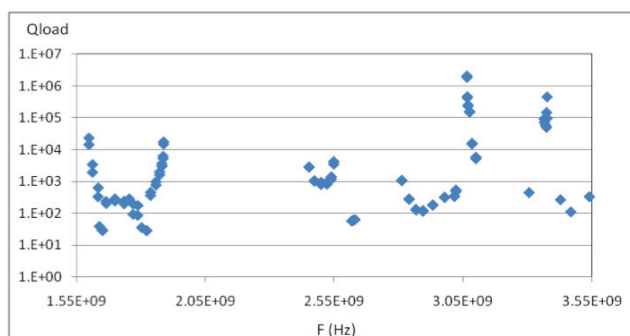

Figure 5: The loaded Q for modes of six dipole bands in the Cornell 7-cell ERL closed cavity with HOM absorber  $\epsilon_r = 30-i10$ .

## REFERENCES

- [1] V. Shemelin, et. al., "Characterization of ferrites at low temperature and high frequency", Nuclear Instruments and Methods in Physics Research A 557 (2006) 268–271.
- [2] E. Chojnacki, et. al., "DC Conductivity of RF Absorbing Materials", Presented at the 14th International Conference on RF Superconductivity, Berlin (SRF 2009).
- [3] V. Shemelin, E. Chojnacki, "RF Absorber Studies Using Transmission Lines", HOM10 Workshop, Cornell University, Oct. 2010.
- [4] F. Marhauser, "Absorber Materials at Room and Cryogenic Temperatures", HOM10 Workshop, Cornell University, Oct. 2010.
- [5] K. Ko, et al., "Advances in Parallel Electromagnetic Codes for Accelerator Science and Development", Invited talk at 25th International Linear Accelerator Conference (LINAC10), Tsukuba, Japan, 12-17 Sep 2010.