

REVISIONS			
SYM.	ZONE	DESCRIPTION	DATE APP.

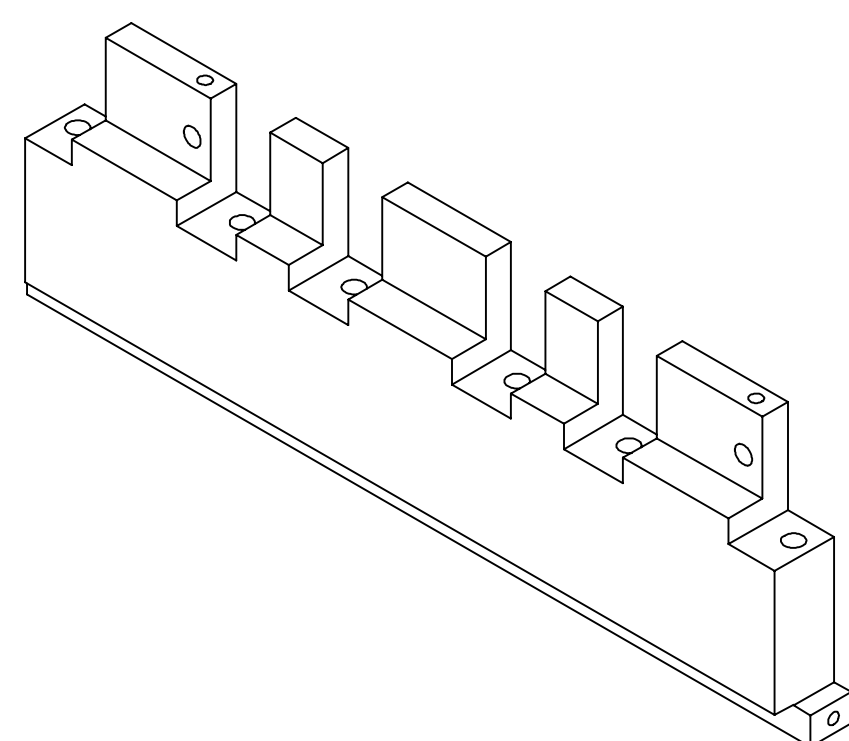
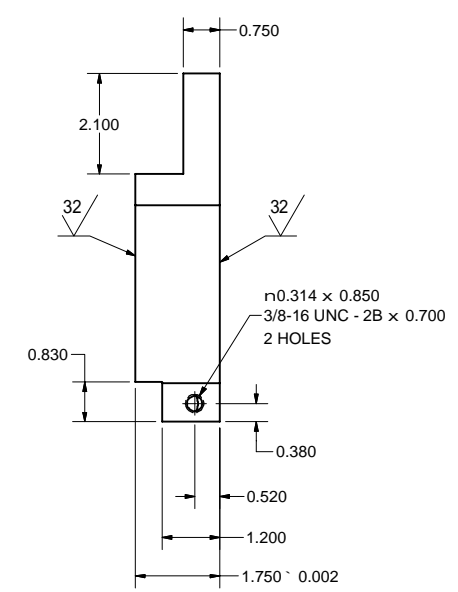
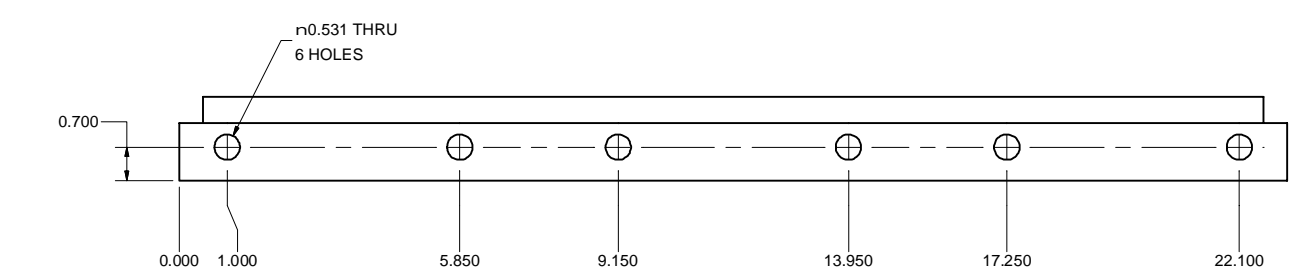
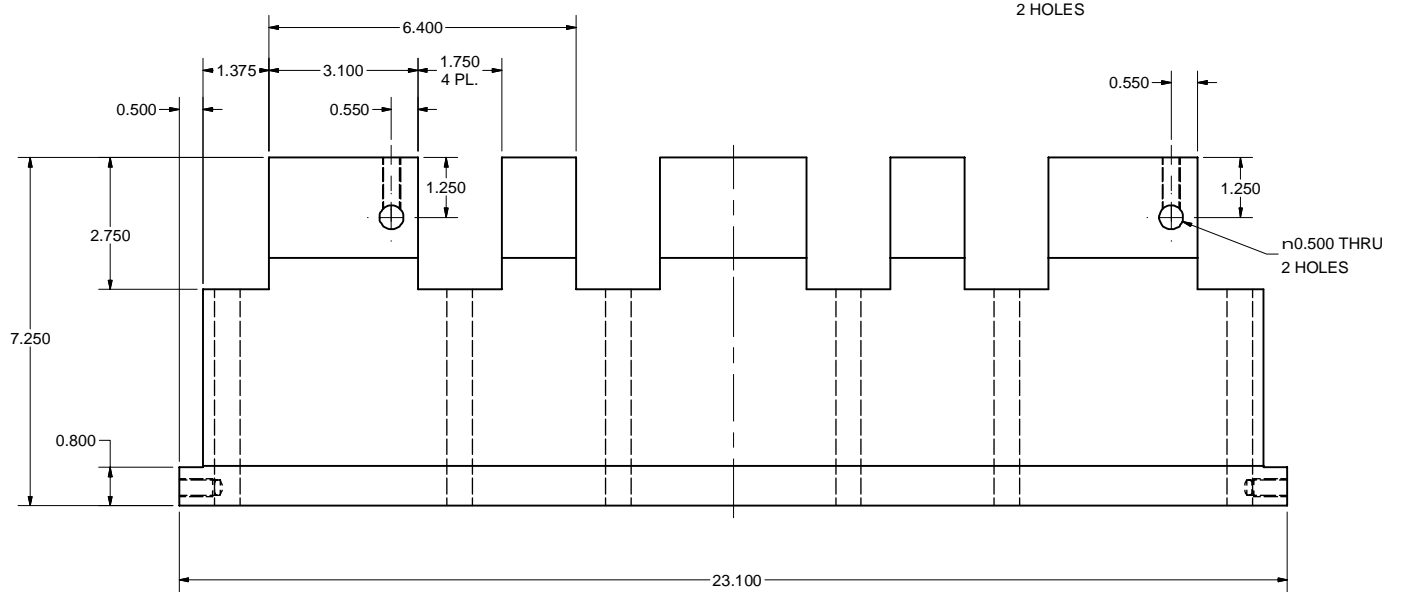
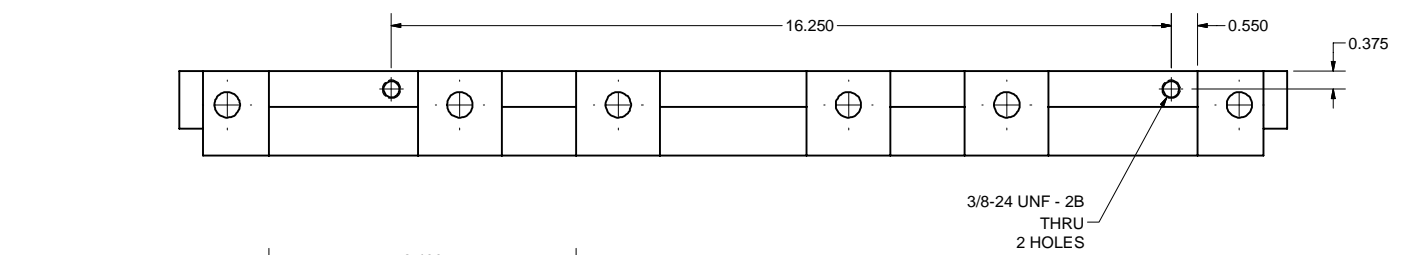

MATERIAL:  
1-7/8" H.R. STEEL SHEET

FOR MACHINING LUBRICANT USE ONLY  
ALKALINE DETERGENT LUBRICANT CIMSTAR 40  
OR EQUIVALENT APPROVED BY CORNELL LEPP

TECHNICAL RESOURCE APPROVALS REQUIRED BEFORE FABRICATION			
	OK	DATE	N/A
DRAFTING (O'Connell):			
MACHINE SHOP (Kaminski):			
CHEMISTRY (Conklin):			
ELECTRONICS SHOP (Barley):			
FURNACE BRAZING (Sherwood):			
BEAM WELDING (Sears):			
WELDING OTHER (Gallagher):			
UTILITIES INTEGRATION (Gallagher):			
STOCKROOMS (Lockwood):			

ITEM	DWG. NO.	DESCRIPTION	G1	G2	G3	REMARKS	REV.
			QUANTITY				
PRINT DISTR.	6041-159-0201	CR-1					
PLOT DATE: 6/30/2004 CAD FILE NAME: 6041-159-0201.idw		<p>UNLESS OTHERWISE SPECIFIED: DIMENSIONS ARE IN INCHES: TOLERANCES ON:     .00 - .010     .000 - .005     FRACTIONS - 1/64     ANGLES - 0.5°     ALL SURFACES ✓</p>					
<p>CORNELL UNIVERSITY LABORATORY FOR ELEMENTARY PARTICLE PHYSICS</p>		<p>CORNELL UNIVERSITY Floyd R. Newman Laboratory Ithaca, NY 14853</p>					
<p>CHECKED BY: MAP APPROVED BY: MAP</p>		<p>DRAWN BY: V.Medjidzade</p>		<p>DRAWN FOR: M.Palmer</p>		<p>DATE: 6/29/2004</p>	
<p>SCALE: (1:2)</p>		<p>REV.:</p>		<p>6041-159-0201</p>		<p>SH. NO. 1 OF 1</p>	