

6 5 4 3 2 1

REVISIONS				
SYM.	ZONE	DESCRIPTION	DATE	APP.

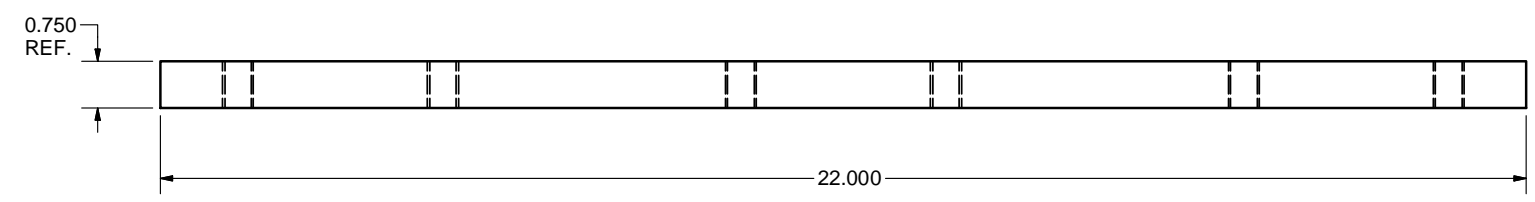
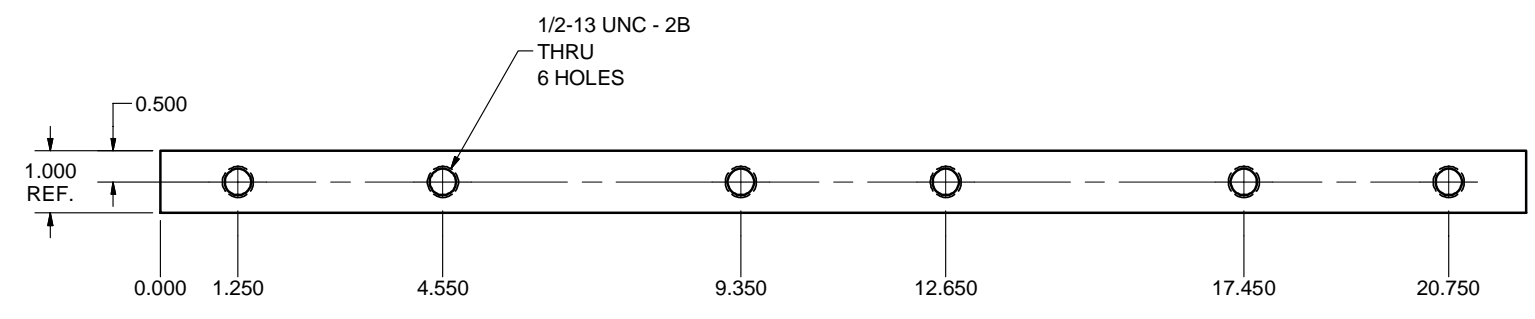
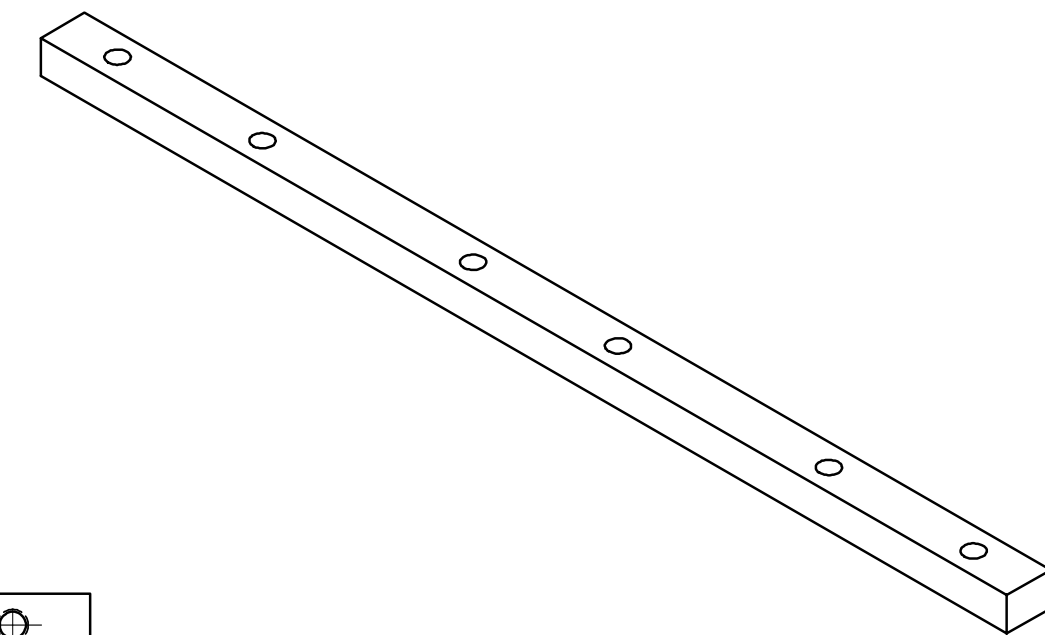

C	6041-159-0204	REV.
	SH. NO. 1 OF 1	

**MATERIAL:**  
3/4" x 1" STAINLESS STEEL RECT. BAR

FOR MACHINING LUBRICANT USE ONLY  
ALKALINE DETERGENT LUBRICANT CIMSTAR 40  
OR EQUIVALENT APPROVED BY CORNELL LEPP

TECHNICAL RESOURCE APPROVALS REQUIRED BEFORE FABRICATION			
	OK	DATE	N/A
DRAFTING (O'Connel):			
MACHINE SHOP (Kaminski):			
CHEMISTRY (Conklin):			
ELECTRONICS SHOP (Barley):			
FURNACE BRAZING (Sherwood):			
BEAM WELDING (Sears):			
WELDING OTHER (Gallagher):			
UTILITIES INTEGRATION (Gallagher):			
STOCKROOMS (Lockwood):			

ITEM	DWG. NO.	DESCRIPTION	G1	G2	G3	REMARKS	REV.
			QUANTITY				
CR-1	6041-159-0204	CLAMP BAR-2					
PRINT DISTR.		PLOT DATE: 6/30/2004 CAD FILE NAME: 6041-159-0204.idw					
UNLESS OTHERWISE SPECIFIED: DIMENSIONS ARE IN INCHES: TOLERANCES ON: .00 ± .010 .000 ± .005 FRACTIONS 1/64 ANGLES ± 0.5° ALL SURFACES $\phi$		 CORNELL UNIVERSITY Floyd R. Newman Laboratory Ithaca, NY 14853					
CHECKED BY: MAP APPROVED BY: MAP		DRAWN BY V. Medjidzade	DRAWN FOR M. Palmer	DATE 6/29/2004	SCALE (1:2)	C	6041-159-0204 SH. NO. 1 OF 1

6 5 4 3 2 1