

Charged Particle Tracking

DR3 ZD TPC

Richard S. Galik
CESR-CLEO Mini Course
December 2006

D. Peterson et al., "DR3", NIMA478, 142 (2002)

D. Peterson, K. Ecklund, M. Shepherd
<http://www.ins.cornell.edu/public/CLEO/DR101/>

M. Selen, "The CLEO-c Trigger", Jul '03

Overview

- Types of gaseous detectors
- Functionality of DR3 and ZD
- Physical description of DR3 and ZD
- Coordinate and momentum measurement
- Signal generation in a drift chamber
- Readout of CLEO drift chambers (David Kreinck)
- Triggering with DR3
- Particle ID (Ahren Sadoff)
- New directions - a TPC for the ILC

Types of Gaseous Detectors

- Gas is ionized and electrons gain KE in \mathbf{E} and lose it ionizing more molecules ... called "gas amplification" or "gas gain"
- With no "gain" we collect the ions (ion chamber, dose meter)
- With large fields and a gas to absorb γ 's ("quenching") can get large signals proportional to the number of primary ionizations (MWPC, drift chamber, TPC)
- With large fields and no "quenching" one gets a discharge (Geiger tube, spark chamber, limited streamer chamber)

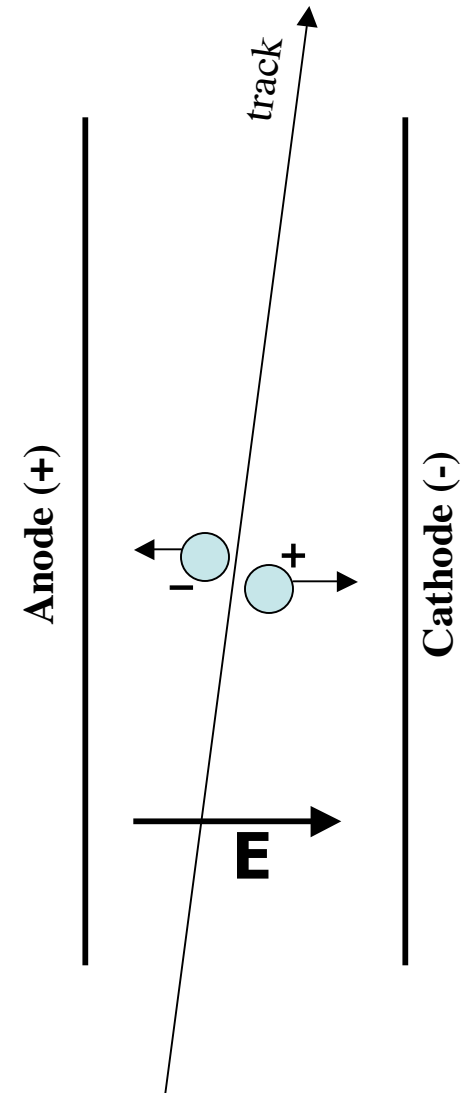

Functionality of DR3/ZD

What do expect out of our drift chambers?

- 1) **Reconstruct** all the charged tracks once
- 2) Accurately determine their **momentum**
- 3) Measure **dE/dx** to help determine species
- 4) Determine **vertices** of long-lived neutrals
- 5) Provide **entrance point** to RICH
- 6) **Trigger** the readout system

Basic Chamber Construction

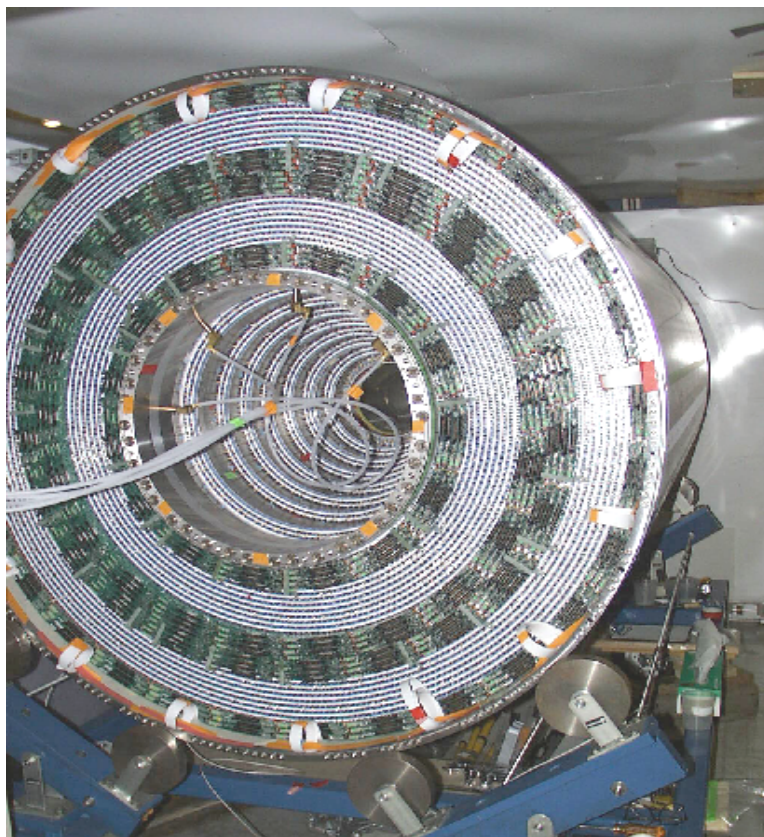

CLEO III/c drift chamber (**DR3**)
1999 – present
Design/Construction: 1992 - 1999

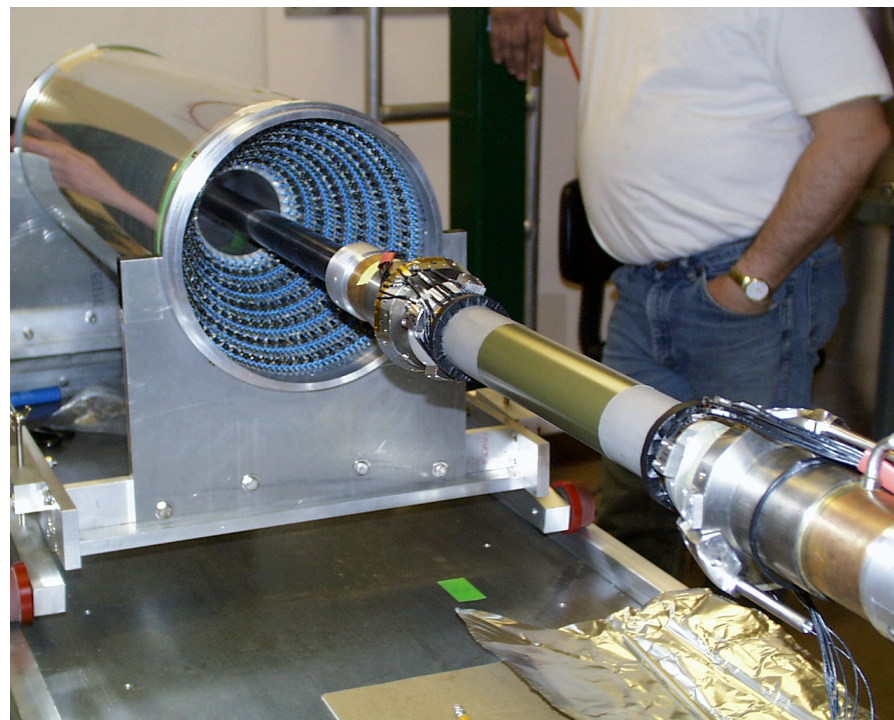

CLEO c inner drift chamber (**ZD**)
2003 – present
Design/Construction: 2001 - 2003

Inside DR3

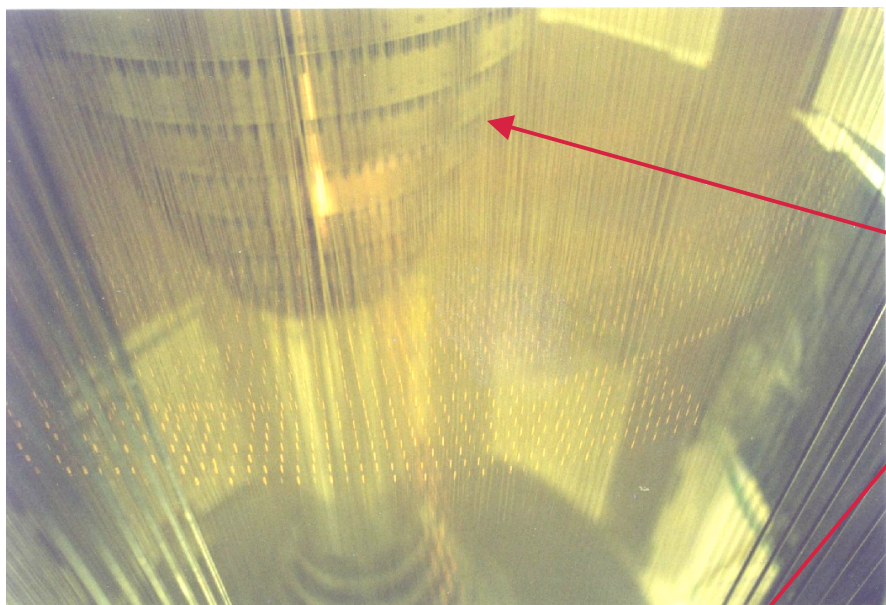

9796 sense wires
29693 field wires ($\sim 3:1$)
outer cathode strips (for "z")

"wedding cake" inner structure with 1696 sense wires; follows $\cos \theta \sim 0.93$

conical "big" end plate with 8100 sense wires and minimal mass

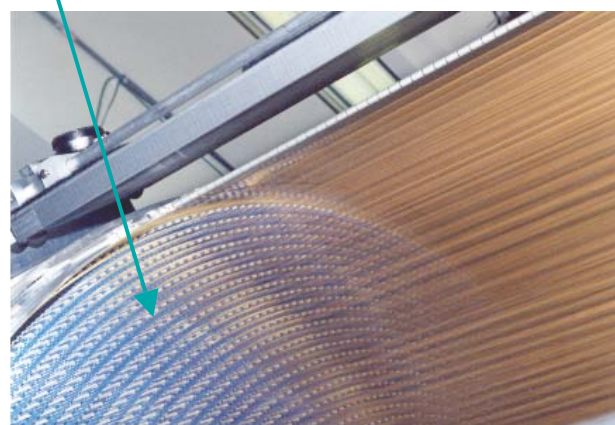
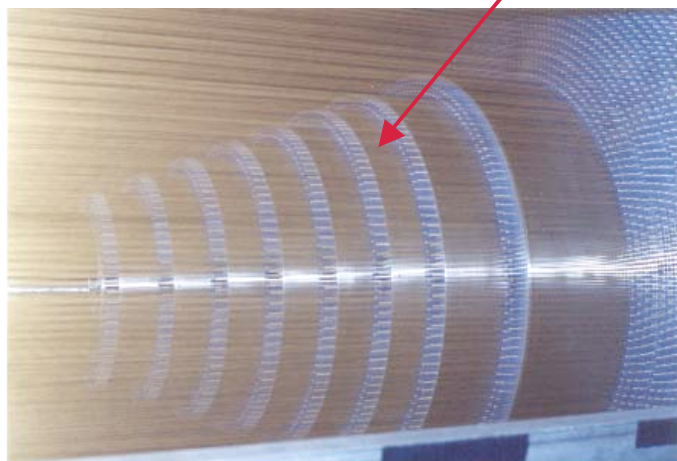

ZD after Stringing

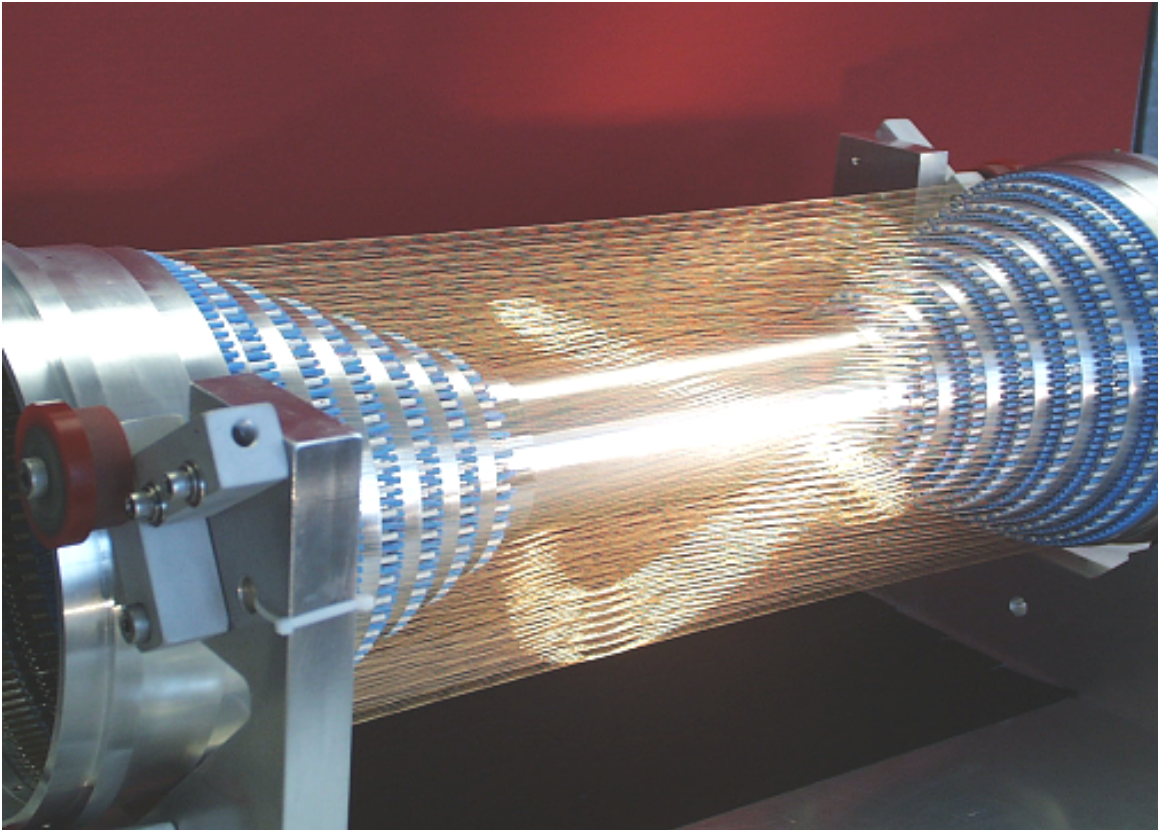

- 300 cells and about 1000 field wires
- Uses the same wires, pins and bushings as DR3
- All stereo ... this chamber was made to provide sufficient z measurements at small radius ... the stereo angle is very large
- Minimal material

Final Wiring of DR3



10 December 2006

RSGalik - DR3 101

8

ZD and DR3 Ring 1

We will not see this again
if we are lucky.
West end, as seen by electrons.

DR3 axial ring 1,
layer 2 connected

DR3 axial signal coax

DR3 ground strips

DR3 F1- voltage distribution

ZD cables

ZD gas

ZD support

beam pipe cooling

permanent magnet support ring

beverage

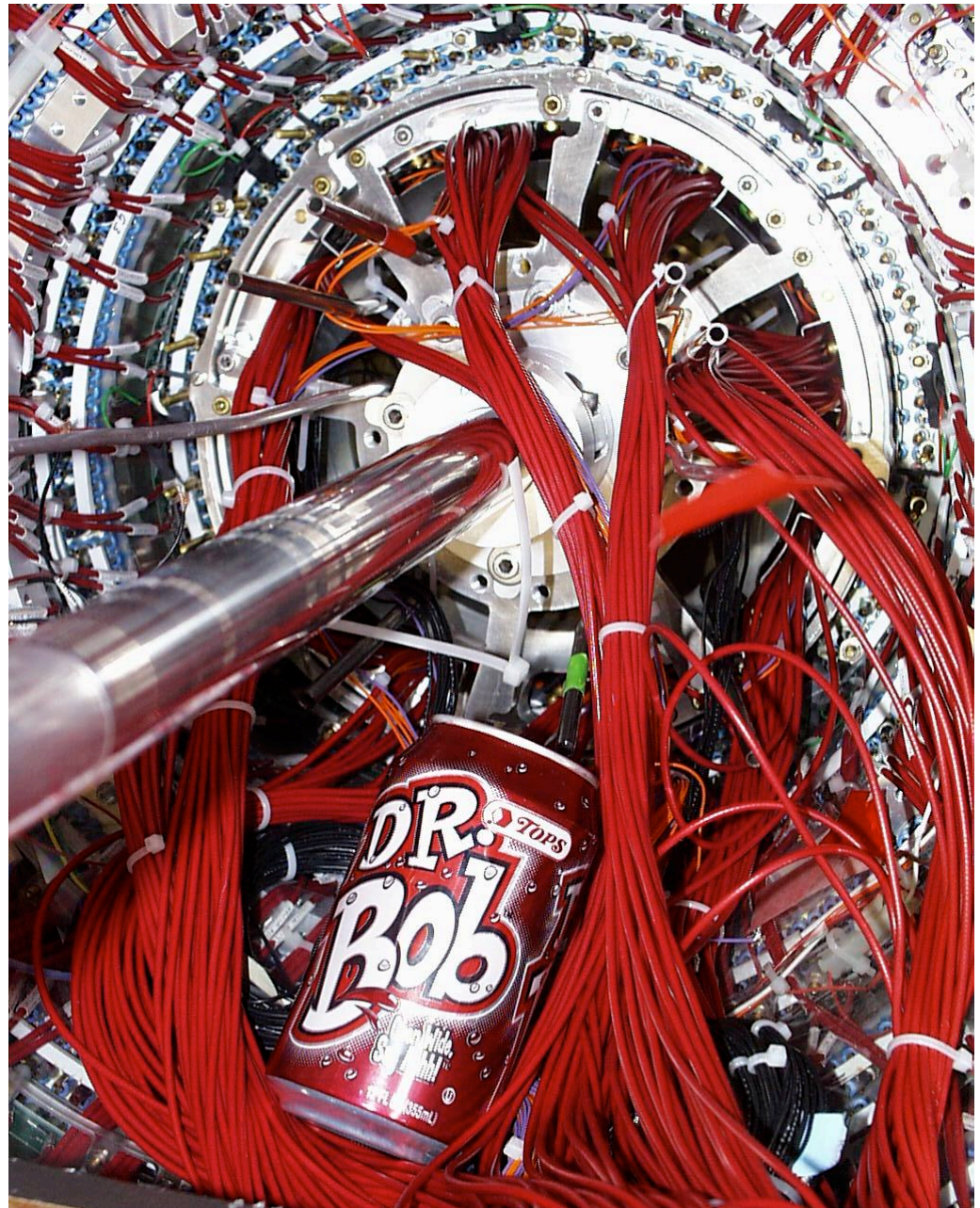

10 December 2006

RSGalik - DR3 101

9

The Cell Structure

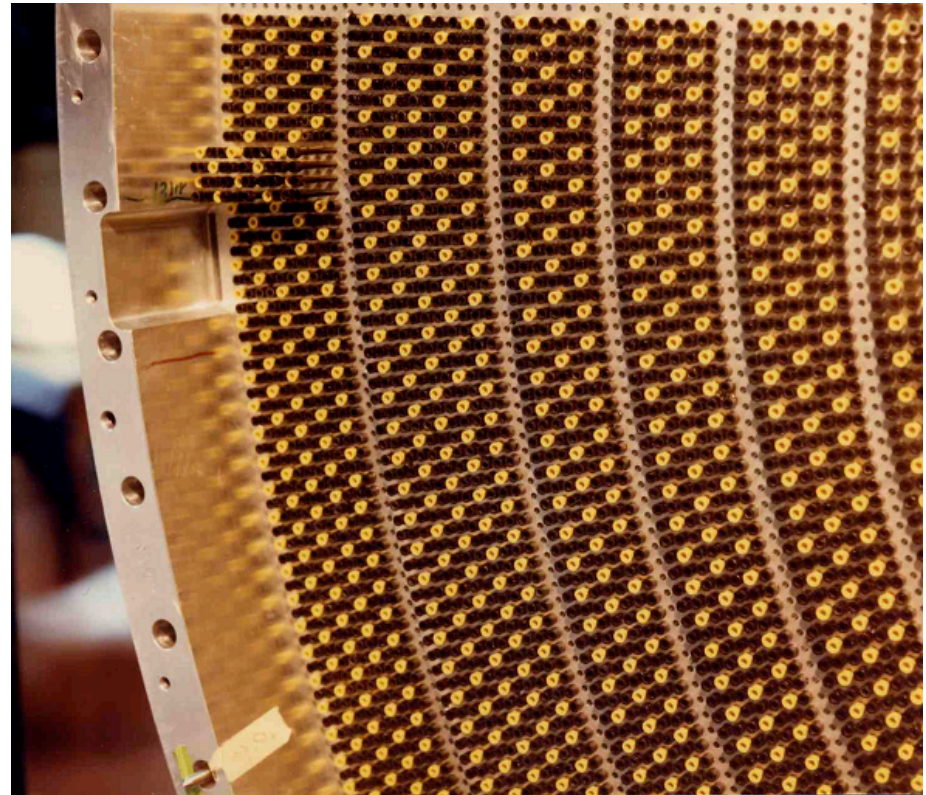
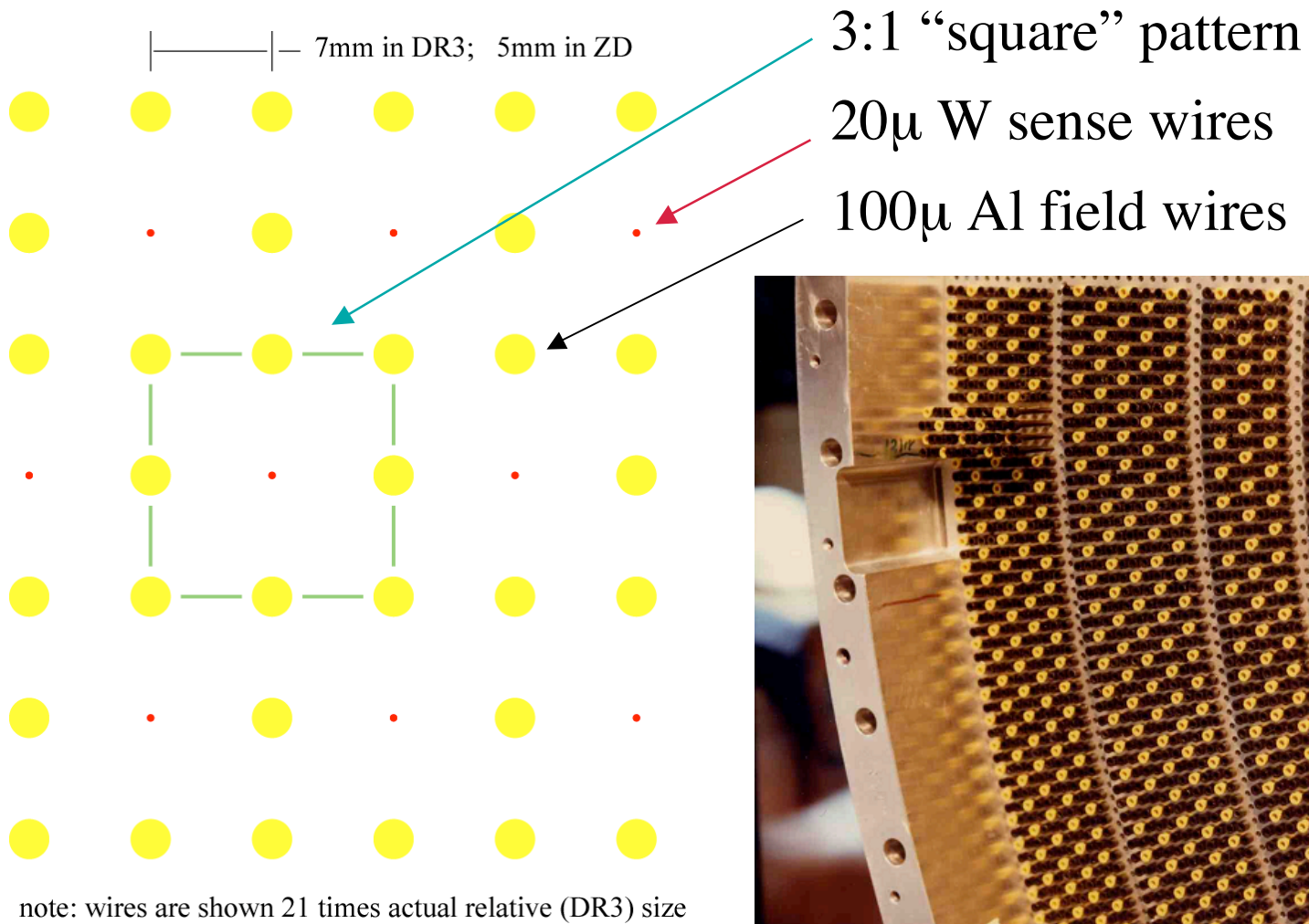

Super layers

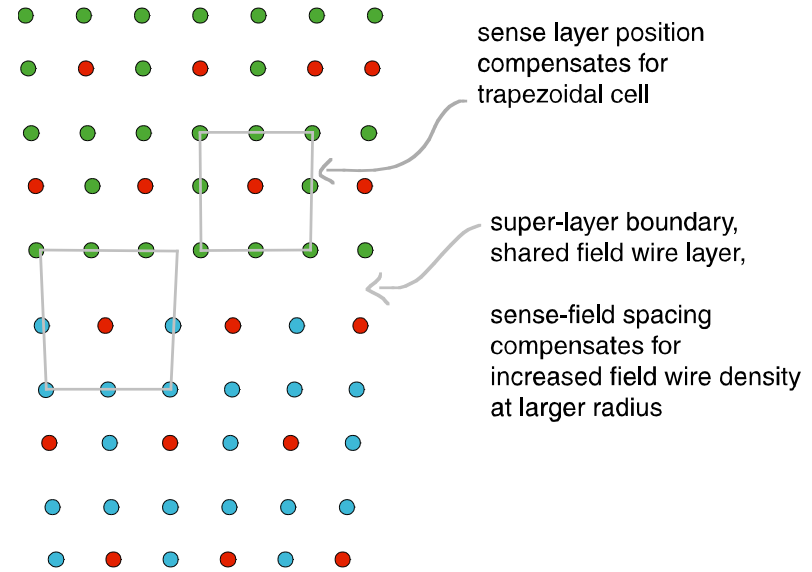
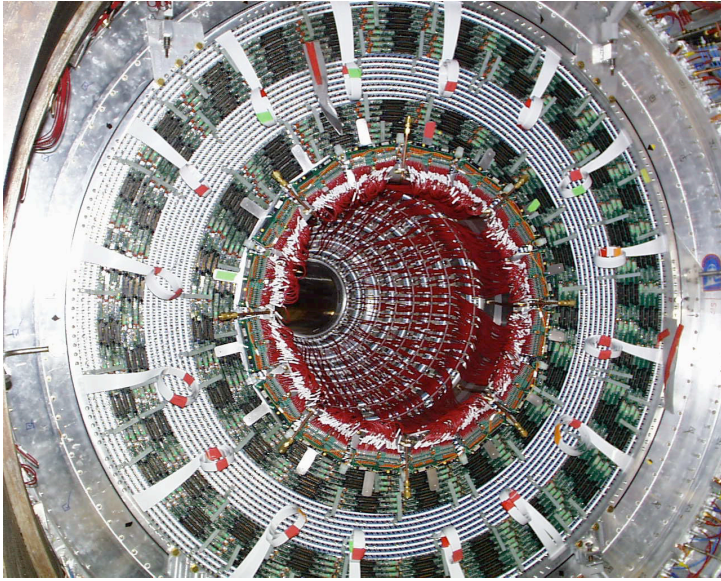

In DR3, the stereo layers are arranged in super layers, with 4 layers/superlayer. Within the superlayer, there are the same number of wires per layer, half cell stagger.

To save space at superlayer boundaries,
the first field wire layer of the larger radius super layer
is also used as the last field wire layer of the smaller radius super layer.

Other considerations ... cathode as a ground plane ... layer1 issues ...

Electron Trajectories with E and B Fields

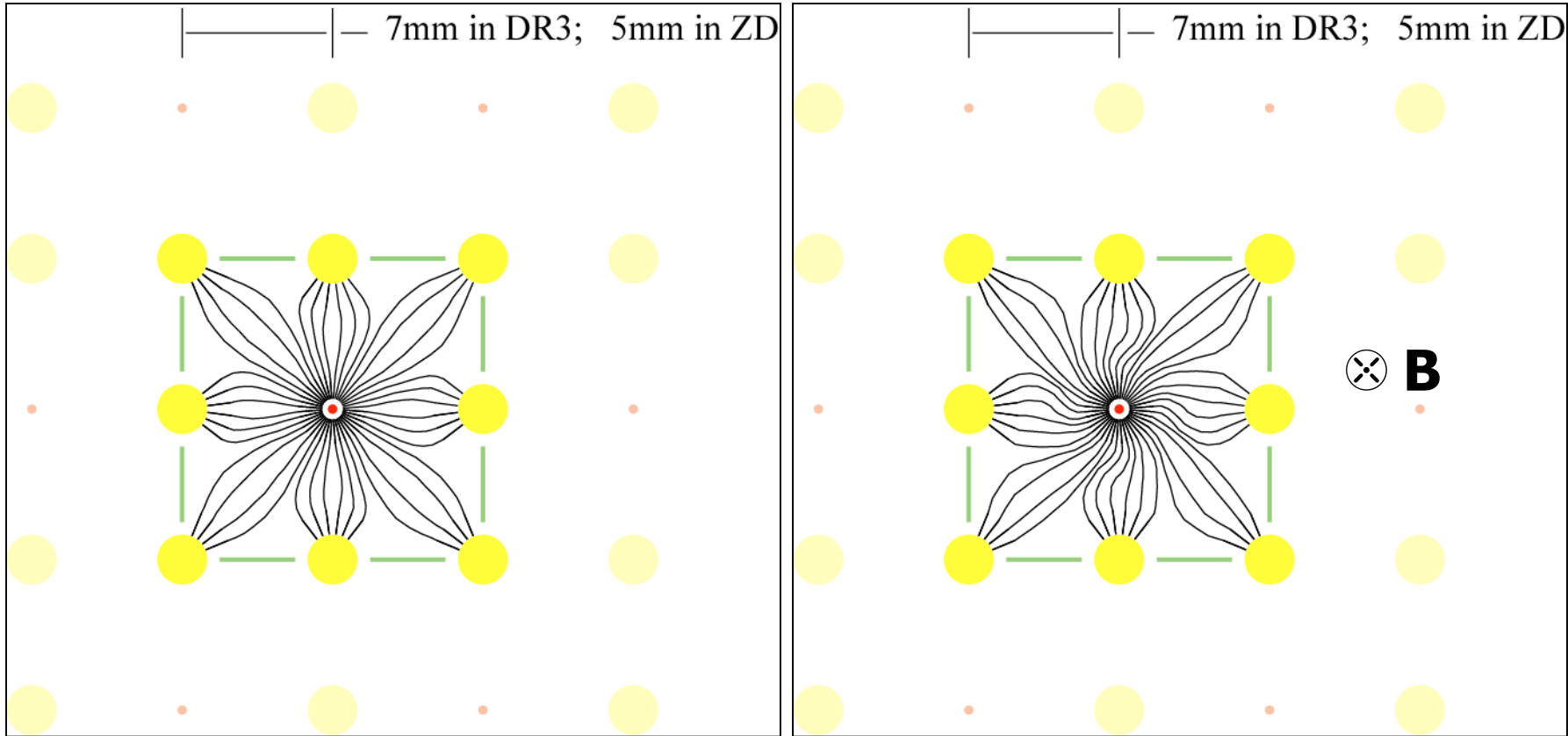

The sense wire is at a potential of +2100V (+1900V) in the DR3 (ZD) Field wires are at ground, for noise suppression.

Field lines are effectively twisted in a magnetic field. This leads to many design considerations and corrections that will not be discussed.

Ionization and Drift

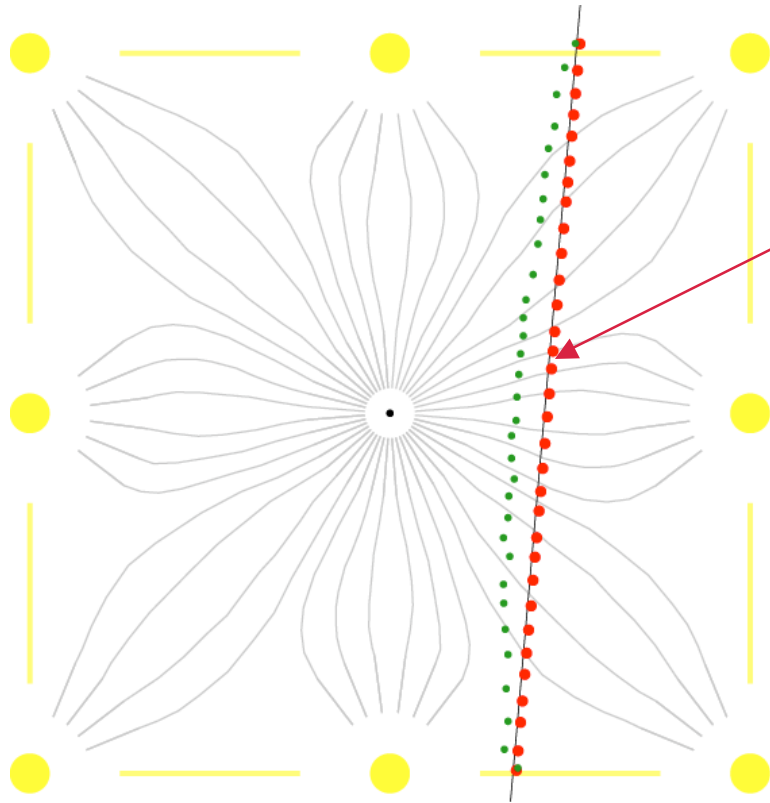

A track traverses the gas and ionizes molecules. How many? There are measurements of the primary ionization cross section (σ_p) and interaction length (λ) at “minimum ionization”.

	σ_p (10^{-20} cm^2)	λ (cm)
He	18.6	1/ 3
Ar	90.3	1/ 24
C_2H_6	161	1/ 43
C_3H_8	269	1/ 72

where $\lambda = 22.4 \text{ cm}^3 / (N_A \sigma_p)$;

In 1.4 cm of He-prop 60:40, ~ 43 **primary** ions

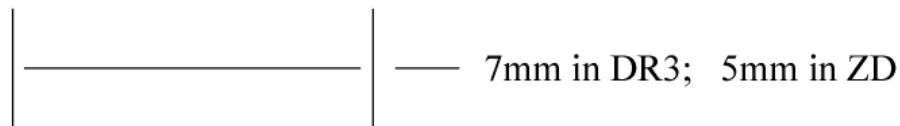

note: wires are shown 7 times actual relative (DR3) size

Ionization and Drift

There is secondary ionization ($\sim x2.5$) when a product of the primary ionization has energy greater than the ionization energy. However, this does not change the discreteness of the primary ion distribution.

The electrons drift to the anode with almost constant velocity.

Diffusion disrupts the drift. Re-combination, or attachment to oxygen, could absorb the electrons.

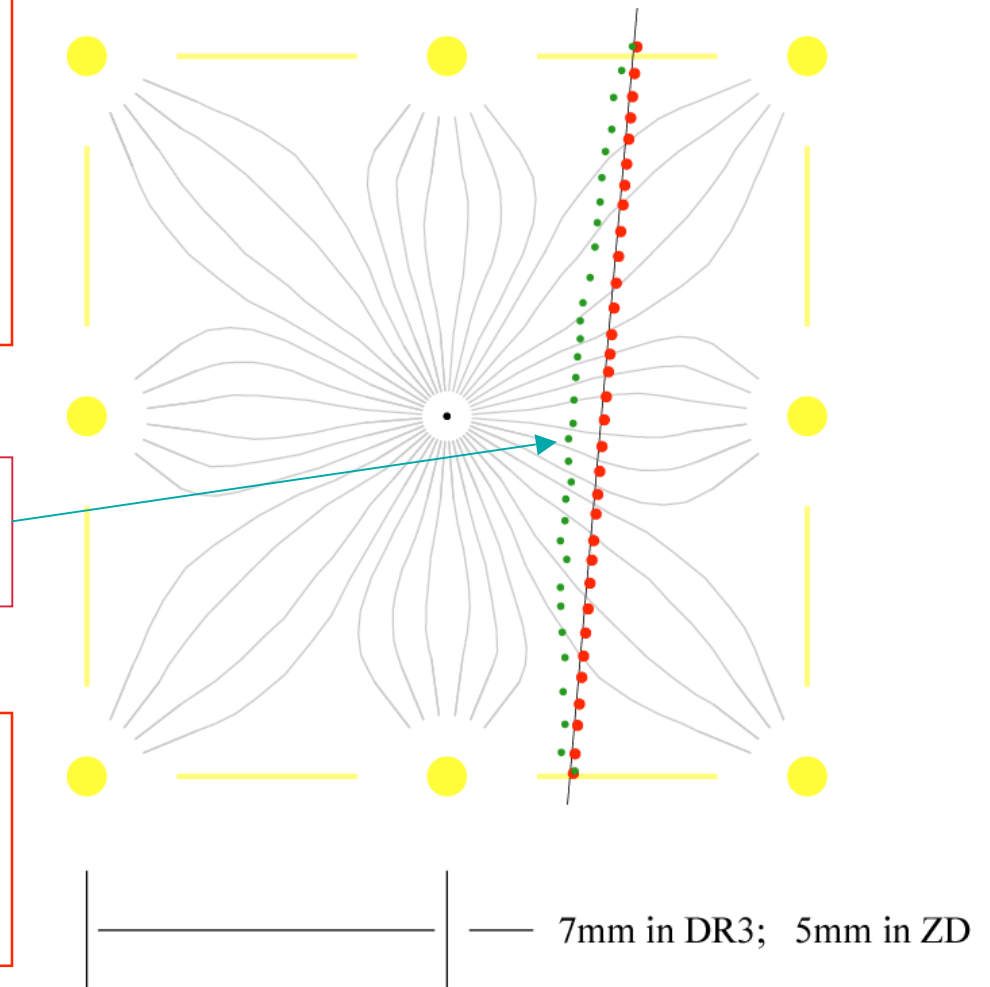

note: wires are shown 7 times actual relative (DR3) size

Drift Velocity

Drift velocity depends on acceleration in the electric field and mean free path: $v \propto E\tau/m$

Drift velocity for Ar-methane mixes
Early DR3 running was 50-50%

CLEO operates at 3 kV/cm (average)

note: velocity is “saturated” (flat)

also note:
those dashed lines at 5 cm/ μ s
are all on top of each other

5 cm/ μ s = 50 μ m/ns

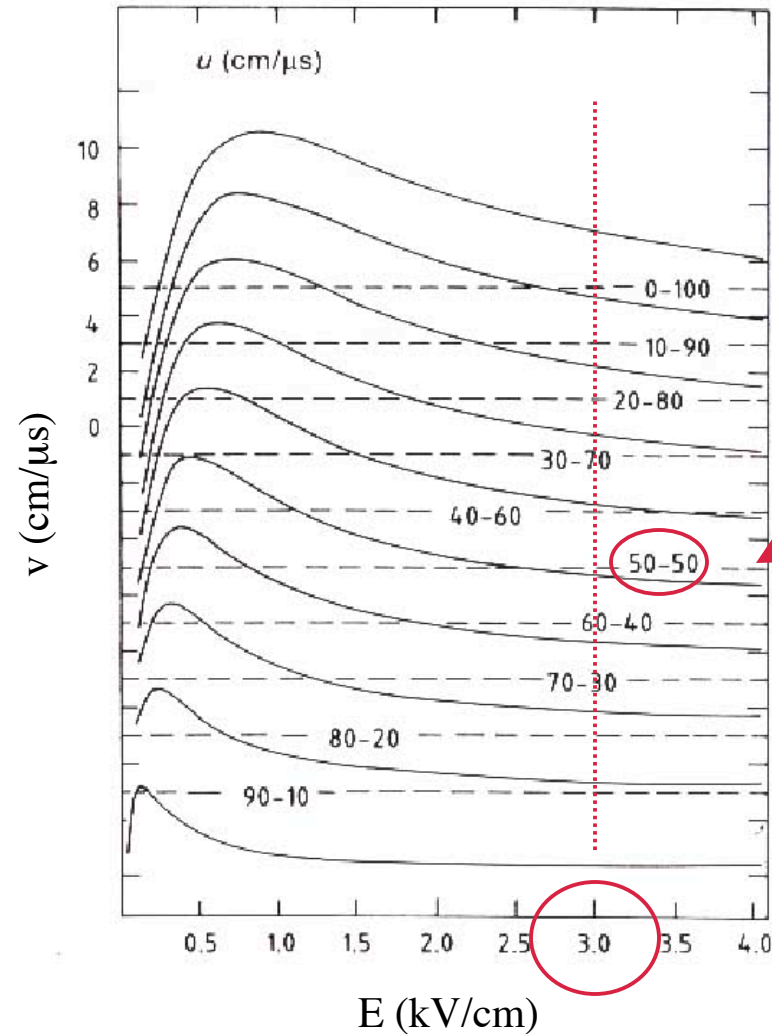

Radius of Avalanche

$E(r) = \Lambda / r$ where “ Λ ” is $\lambda/(2\pi\epsilon_0)$;
and λ is the charge density

Integrating...

$V = \Lambda \ln(b/a)$ where b is the cell “radius”
 a is the wire radius (10μ)

V is the applied voltage (2100V)

$E(r) = V / (r \ln(b/a))$

For DR3: $b = 7000\mu$, so $1/\ln(b/a) = 0.15$

At $E = 5 \times 10^4$ V/cm, an electron gains the
ionization energy (~ 20 eV) between each
collision ($\sim 4\mu$)!

Plugging in, this occurs at about $r = 63\mu$.

Typical “gain” of 10,000 !!

[More on this later!]

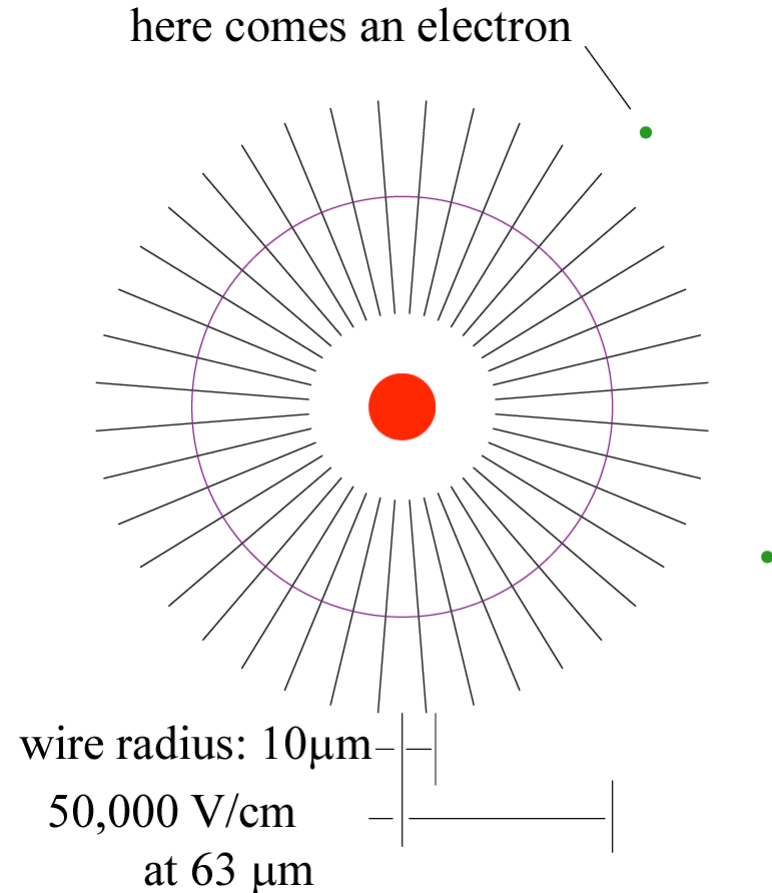

Spatial Resolution

Residuals: time-measured hit position are compared to the fitted position.

Parameterized as double Gaussian with fixed 80% fraction in narrow component.

**Narrow component:
(average over entire cell)
 $\sigma=88 \mu$**

Wide component: 200μ

Average, full cell, all hits : 110μ

(CLEO-III TDR Goal: 150μ !!)

DR residuals summed over layers (Bhabha, Run 114469)

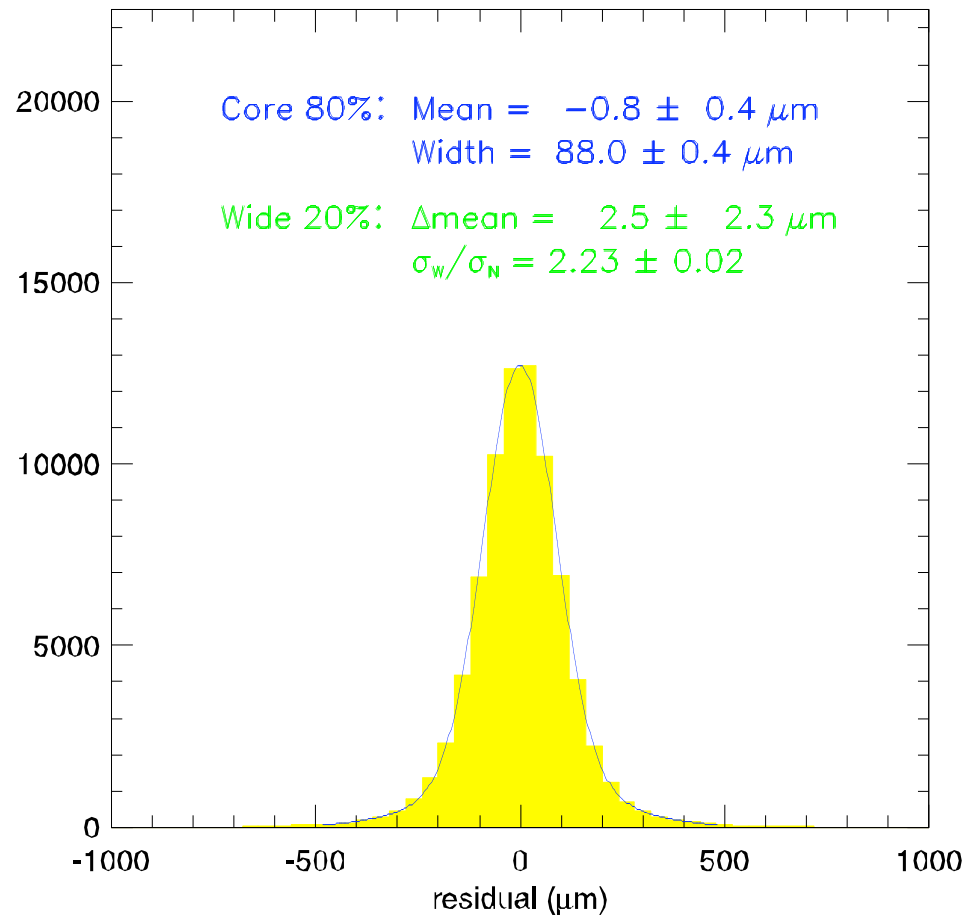

Resolution Across the Cell

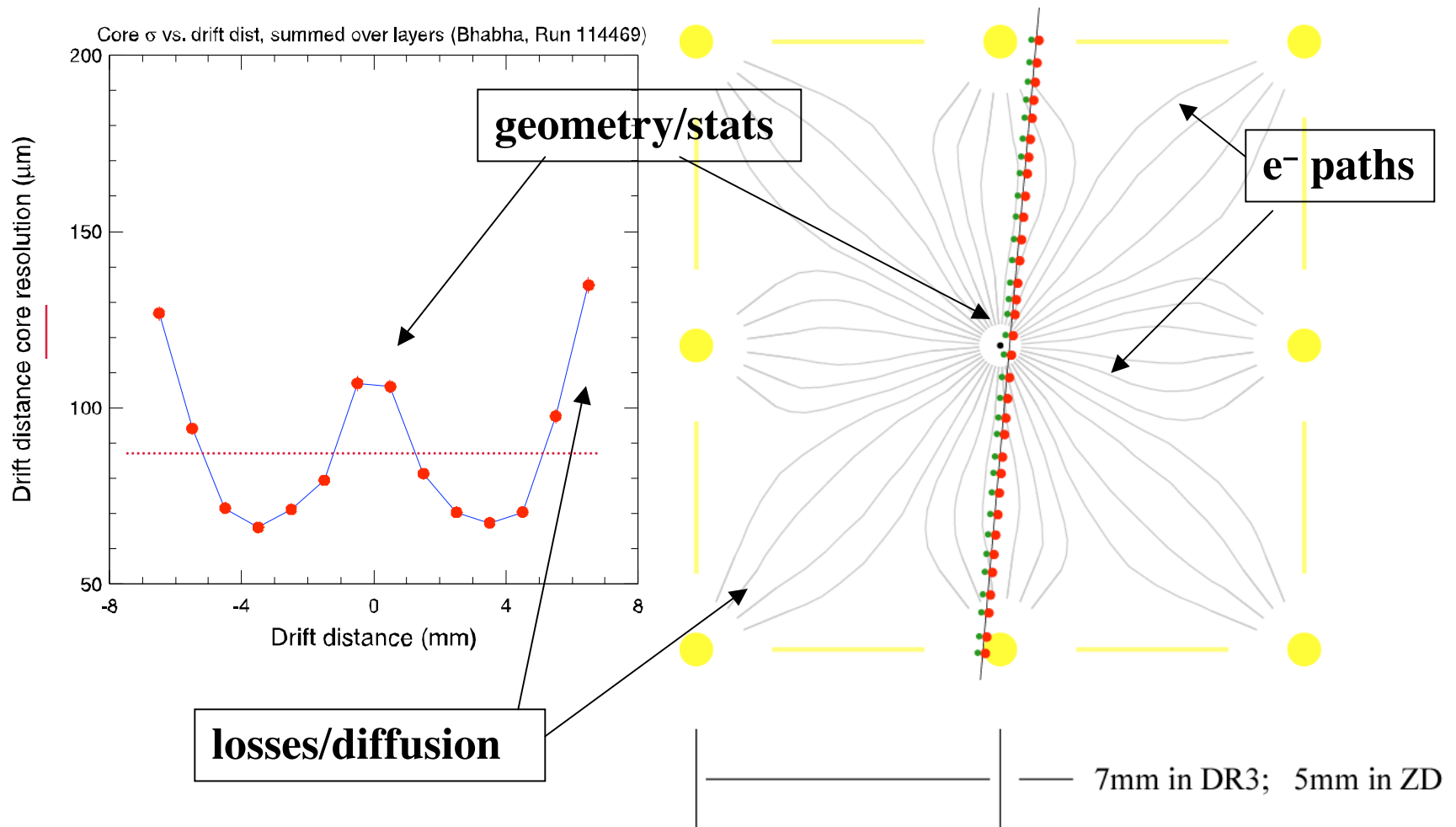

Momentum Measurement

$$R^2 = (R-s)^2 + L^2/4 = R^2 - 2Rs + s^2 + L^2/4$$

$$s = L^2/8R \quad (\text{sagitta})$$

at 1 GeV, $P_t = 150 \text{ MeV} * (2 R / \text{meter})$
 $1/(2R) = 150 \text{ MeV} / P_t / \text{meter}$

$$s = L^2/4 * 150 \text{ MeV} / P_t / \text{meter}$$

$$\delta P_t / P_t = - \delta s / s$$

- measurement error:
 δs is a constant; s^{-1} is proportional to P_t
 so $\delta P_t / P_t \propto P_t$
 and it is proportional to ϵ , the single measurement error

- multiple scattering:
 $\theta = 13.6 \text{ MeV} / \beta c P (x/X_0)^{1/2}$
 $\delta s \sim \theta$, so $\delta P_t / P_t \propto 1/(P_t s) = \text{const}$

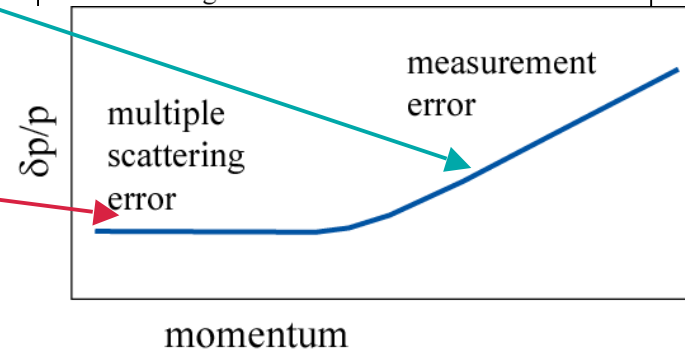
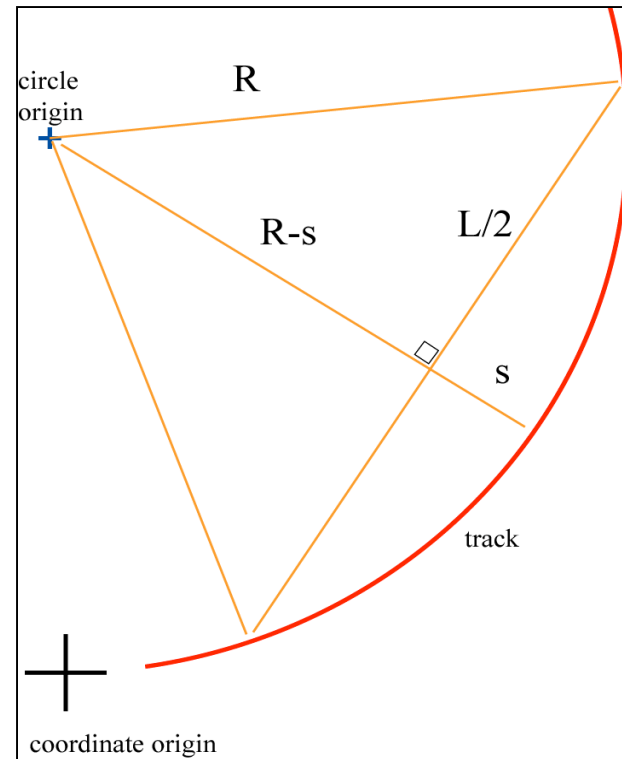

Stereo Measurements of "z"

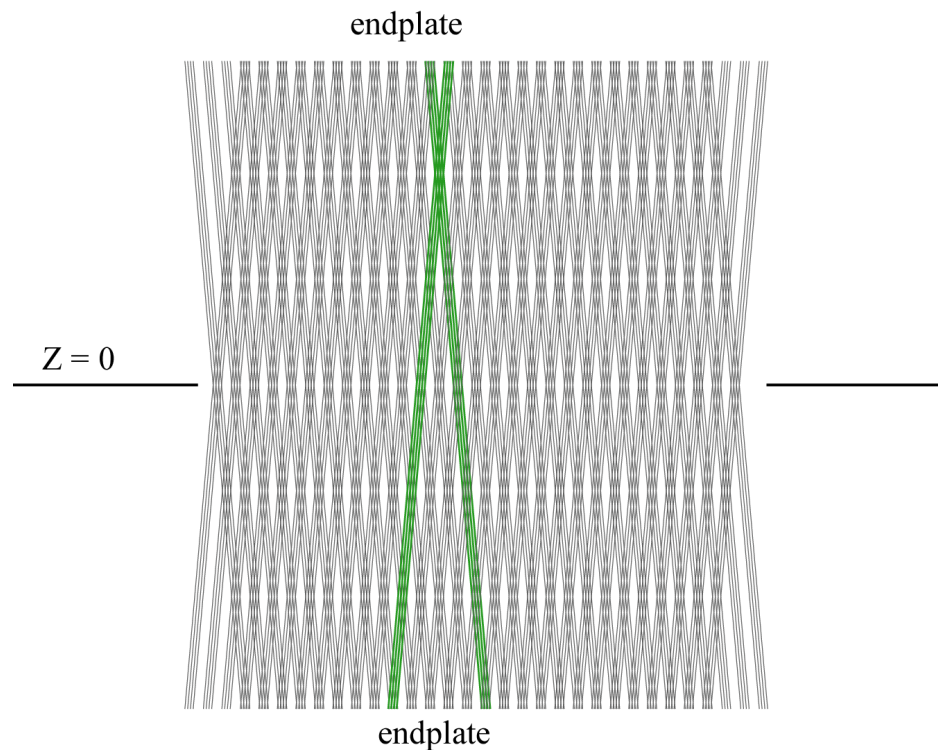
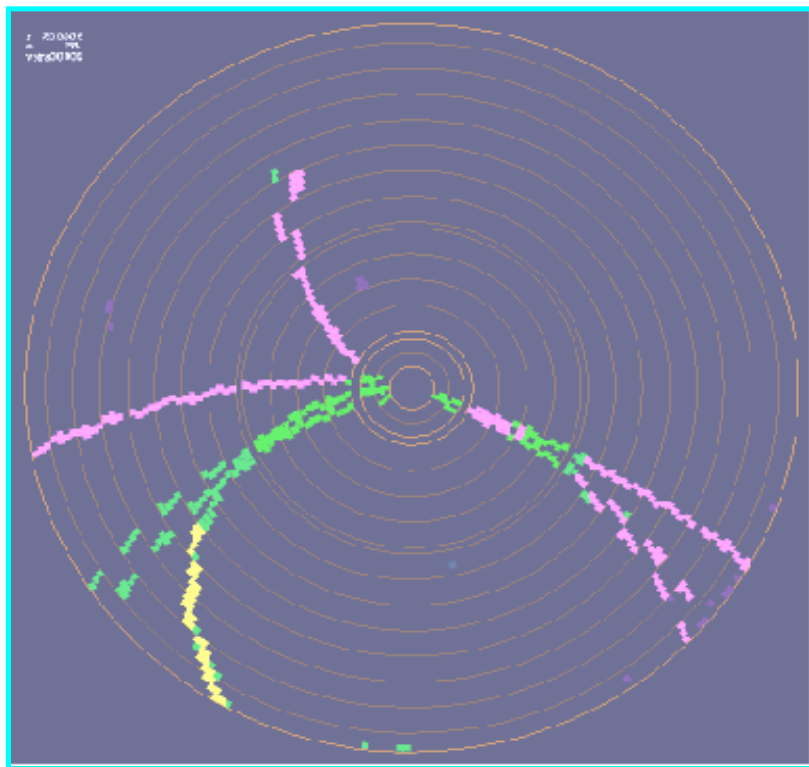

The electronics read-out looks like a 2-dimensional measurement. The CLEO chambers use stereo wires to measure the z coordinate. The event displays show you the wire position at $z=0$.

The Signal at the End of the Wire

pulse height
20 mV /division

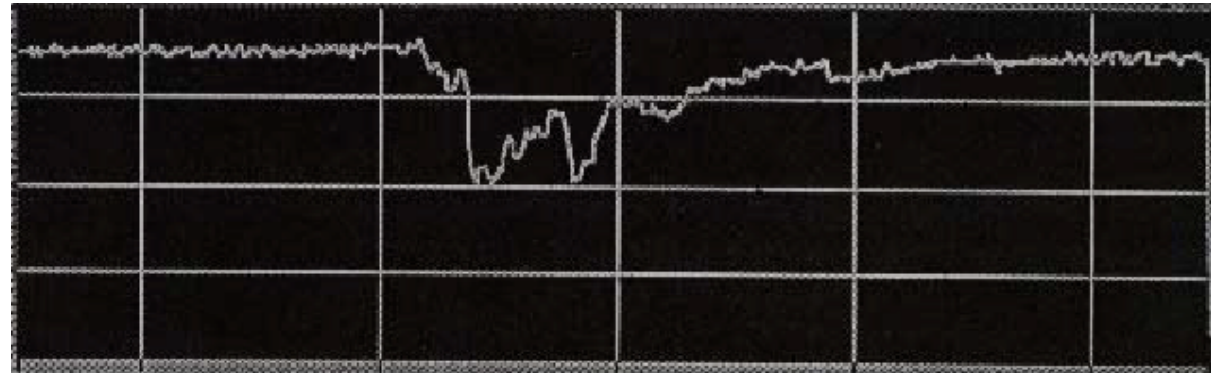

time, 200ns / division

**The avalanche near the wire was a few slides back.
How is this signal developed?**

We are making $\sigma_D = 100\mu$ distance measurements with a drift velocity of $28\mu/\text{ns}$ (He-propane 60:40), thus requiring a time measurement with $\sigma_t = 3.5$ ns. So, the leading edge must be defined to 3.5 ns.

The signal shown has significant voltage over about 150ns (the total electron drift time in our cell is 250ns.)

Some of the substructure is individual arrivals, some is electronic noise.

Why Do We Expect a Signal ?

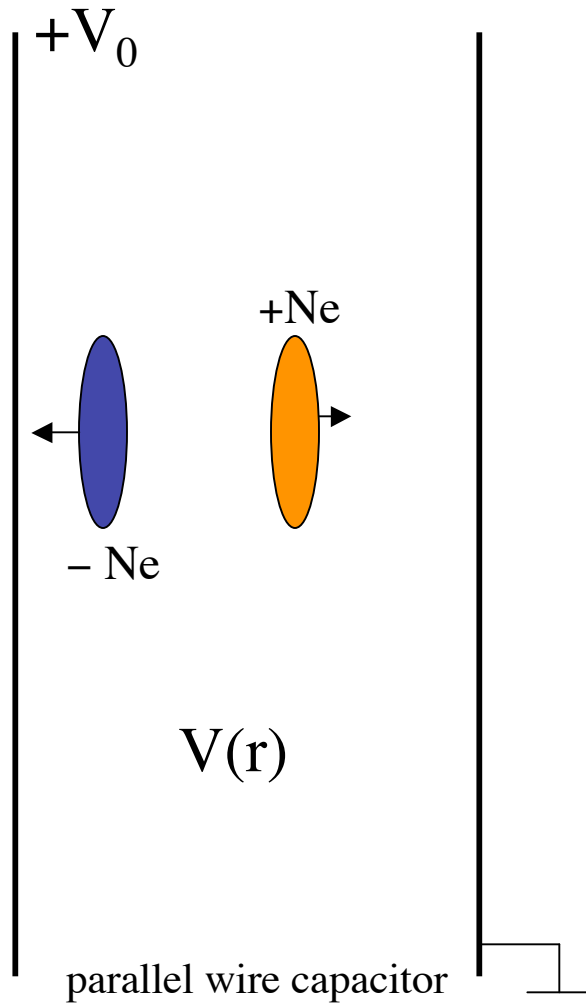

The kinetic energy (T) gained by the particles ($N \sim 10^5$) must come out of the field energy, U!

$$\delta U = CV_0 \delta V \quad \& \quad \delta T = (Ne) (dV/dr) \delta r$$

$$\delta V = (Ne/CV_0) (dV/dr) \delta r$$

(This is the "energy" argument)

Note δV is the same sign for electron and ion motions.

We try to keep V "fixed", so the electronics must supply current, doing work to provide this energy. Both species give the same "sign" signal.

Misunderstandings

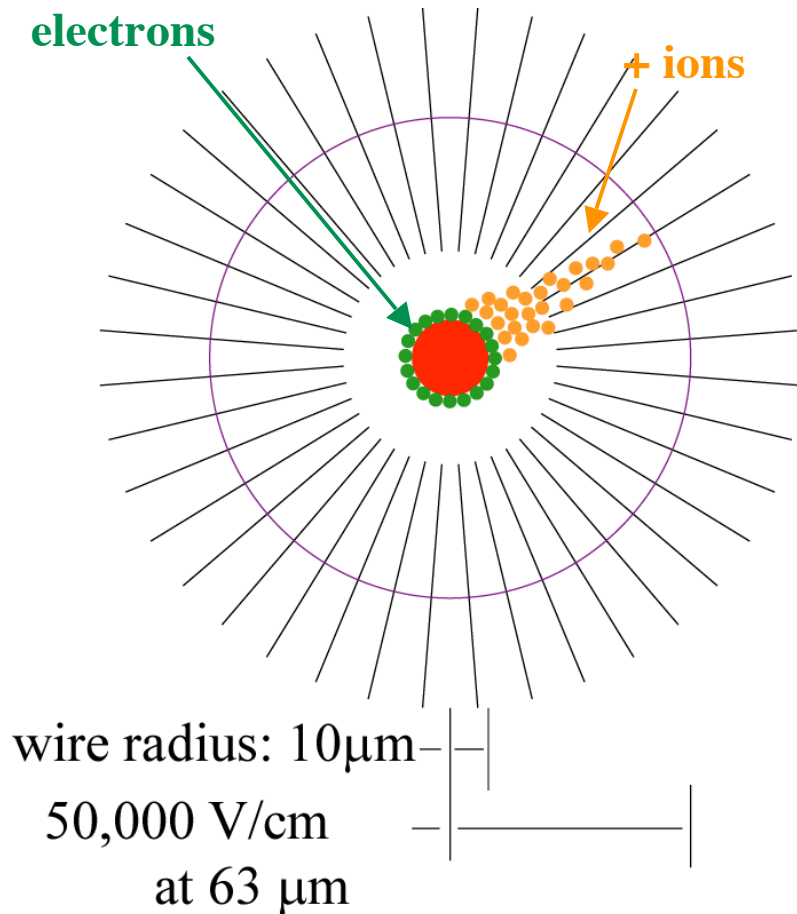

“almost all the energy and all the signal in a proportional counter are due to the motion of the positive ions.”

Blum and Rolandi, p155

“The signal is due to the motion of the positive ions” *various unnamed*

“it is an energy argument” *ibid*

“ it says so in Sauli” *ibid*

The ions move $\sim 10,000$ times slower than the electrons, reaching the cathode in $\sim 2.5\text{ ms}$, inconsistent with the observed signal.

One will never get 100μ resolution with the time dependence on the ion motion!

Signal is differentiated to get sharp edge.

Much of what we see is the fast electron component.

Drift Chamber Electronics Signals to Bits

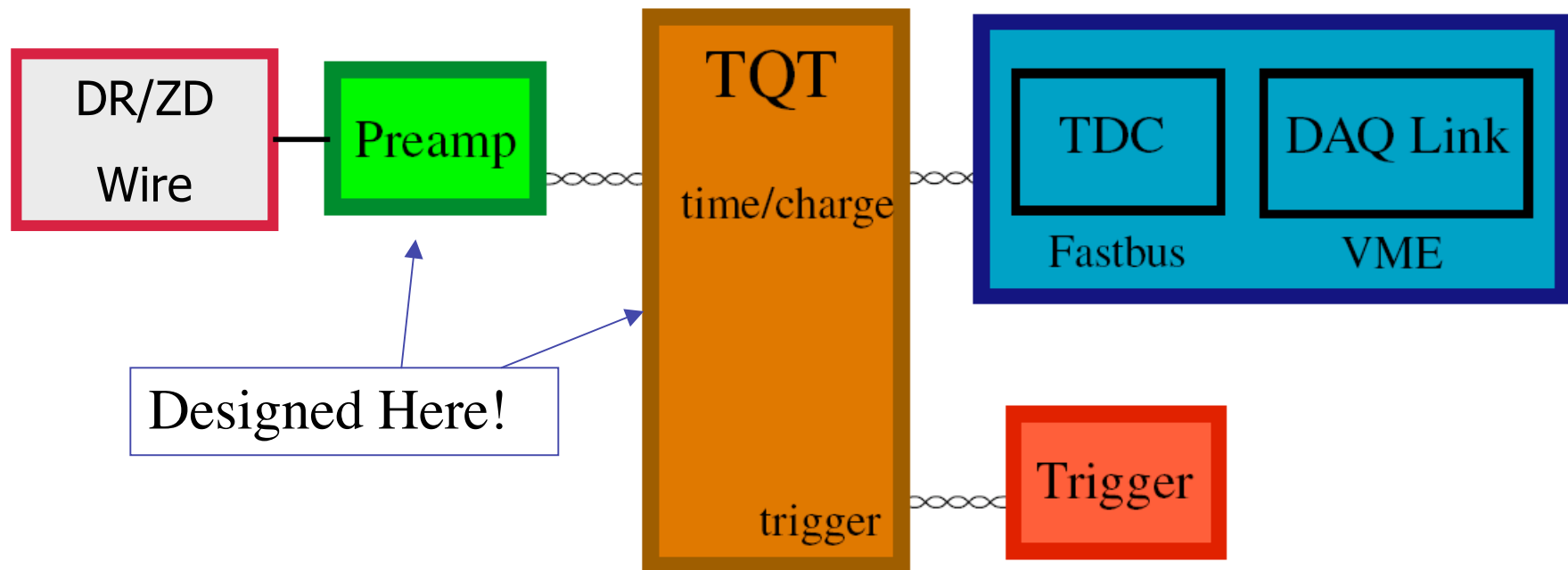

- Preamps on chamber (analog output) - 10,000 wires!!
- Front End Electronics off chamber
 - TQT: time, charge, trigger (digital outputs)
- TDC: "data boards" Fastbus with VME processor

Preamps - Why? How?

Consider one cell with a track going through it.

What's the signal look like?

Think of the chamber as a current source (energy argument)

- One (first) electron avalanche at wire
- Gas gain of 5×10^4
- Rise time of 5 ns

$$I = \frac{Q}{t} \approx \frac{(1.6 \times 10^{-19} \text{ C}) (5 \times 10^4)}{5 \times 10^{-9} \text{ s}} = 1.6 \times 10^{-6} \text{ A}$$

Small currents (μA) \Rightarrow measure directly at the chamber !

Need high bandwidth for fast signals and good timing resolution

Transimpedance Amplifier

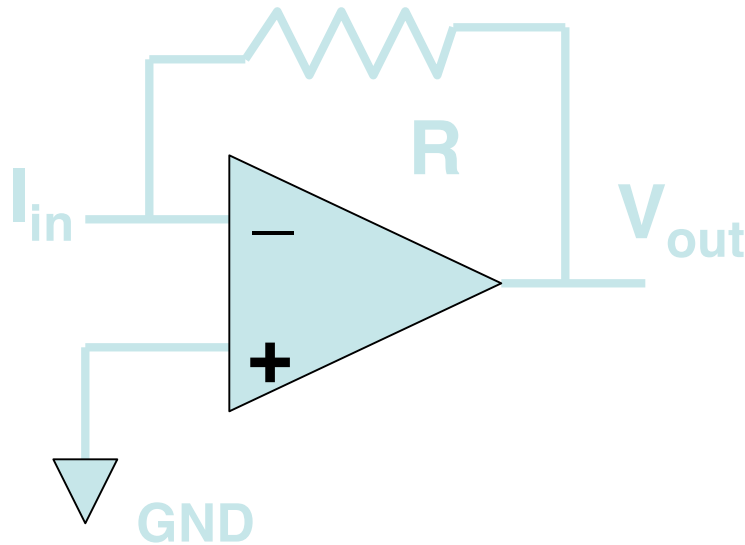
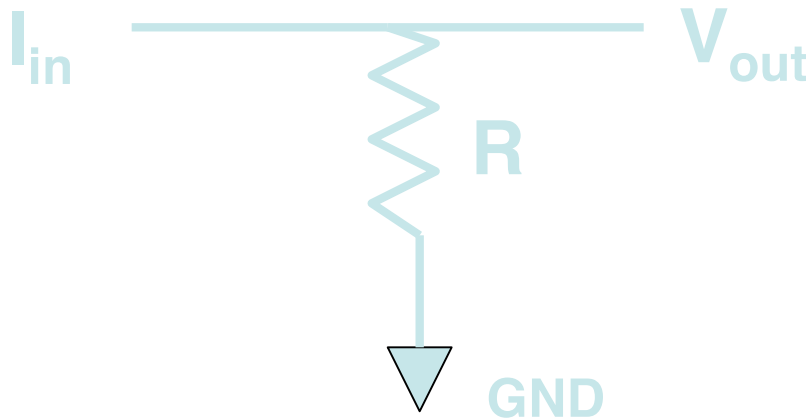

- Transimpedance amp converts current input to voltage output
- Just like a resistor
 - $V_{out} = I_{in} R$
- Op amp circuit
 - uses feedback to make input impedance essentially zero
 - $V_{out} = I_{in} R$
- Our preamp uses discrete components to do the same
- "Gain" is $6 \text{ k}\Omega$
- Balanced twisted pair inputs (CMR)
- 12 channels per module
- Pulser/test-input as well

Preamp Hardware

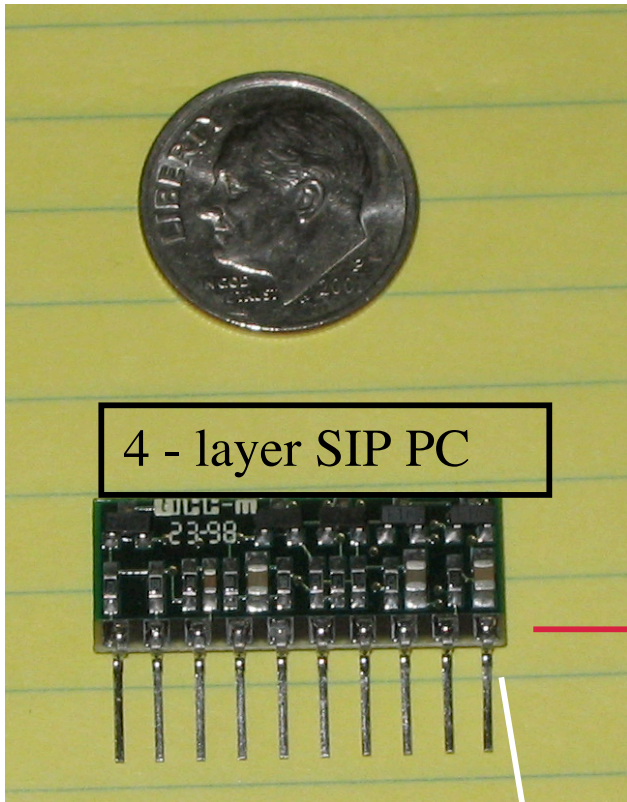

4 - layer SIP PC

80
Axial
Boards

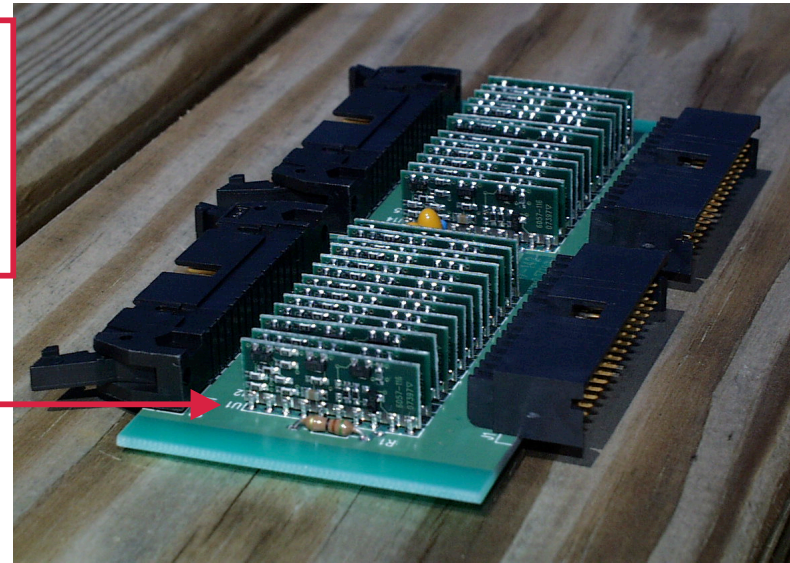

675
Stereo
Boards

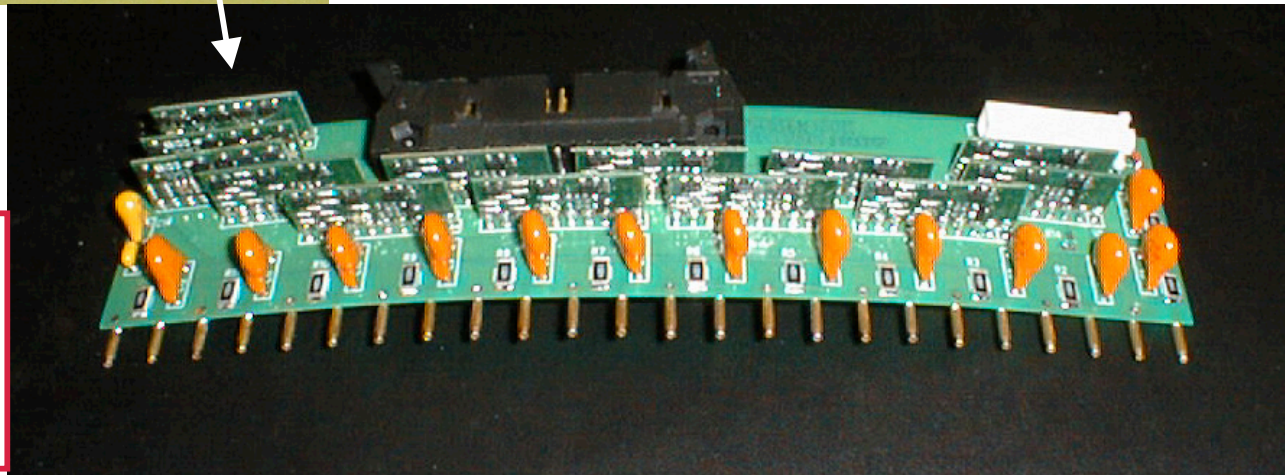

Chamber Signal & Processing - Q&T

- Chamber is a current source
- Preamp is a current sensitive amplifier
- 2 signal paths
 - Fast for timing
 - Slow for charge
- Q→T conversion
- TDC does all readout

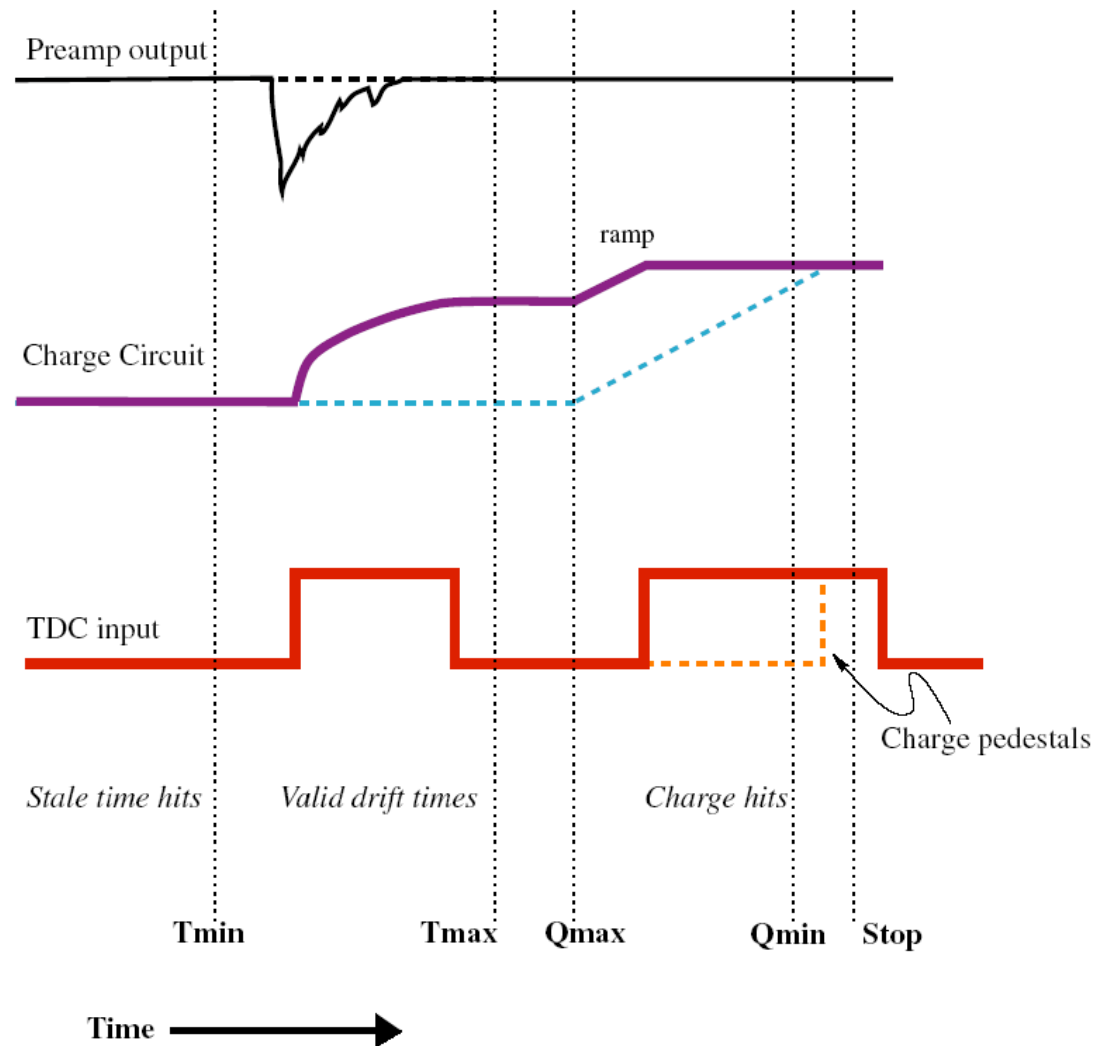

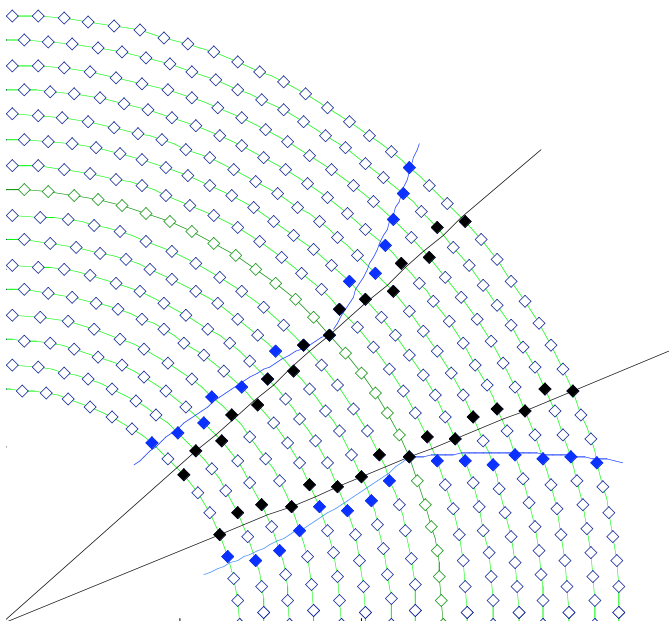
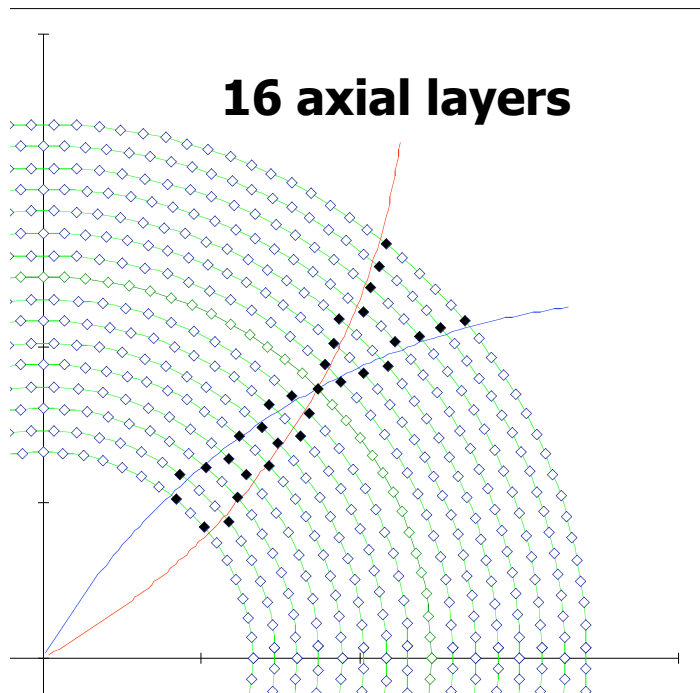

Axial Tracking Trigger

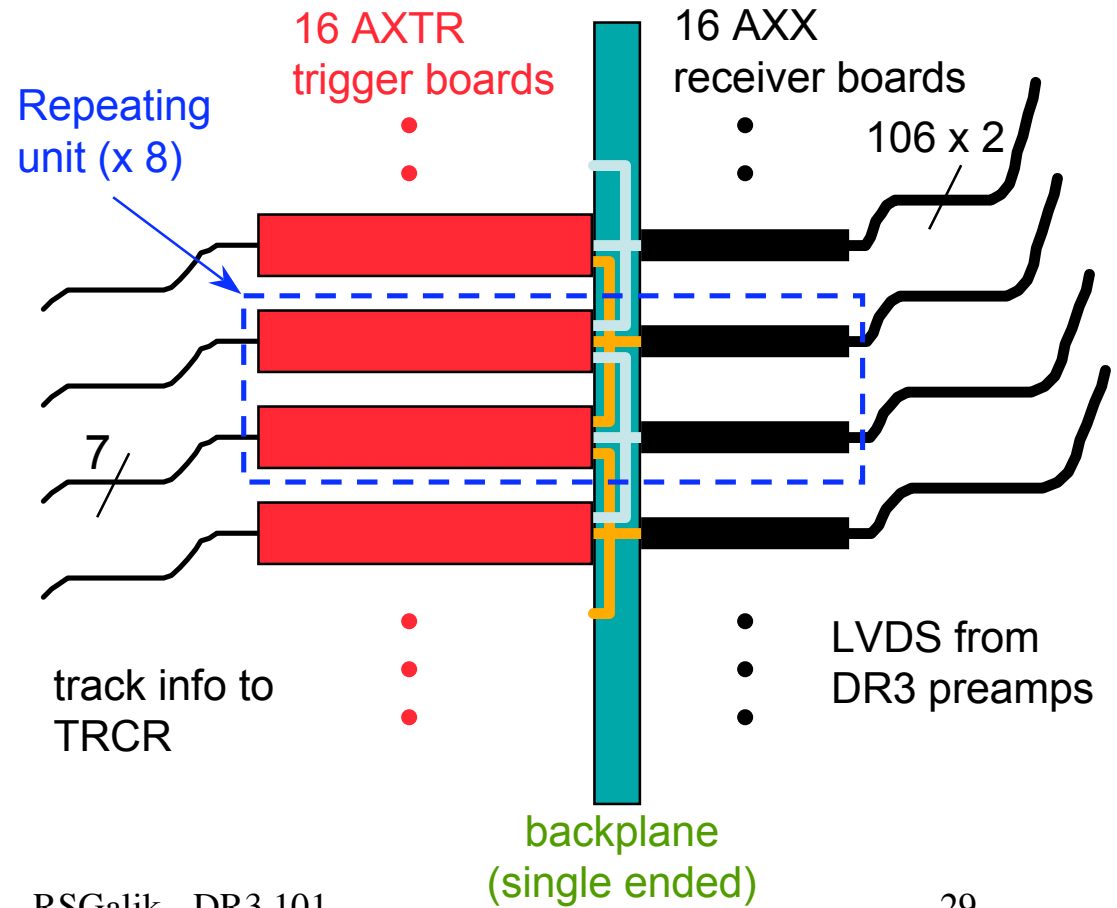

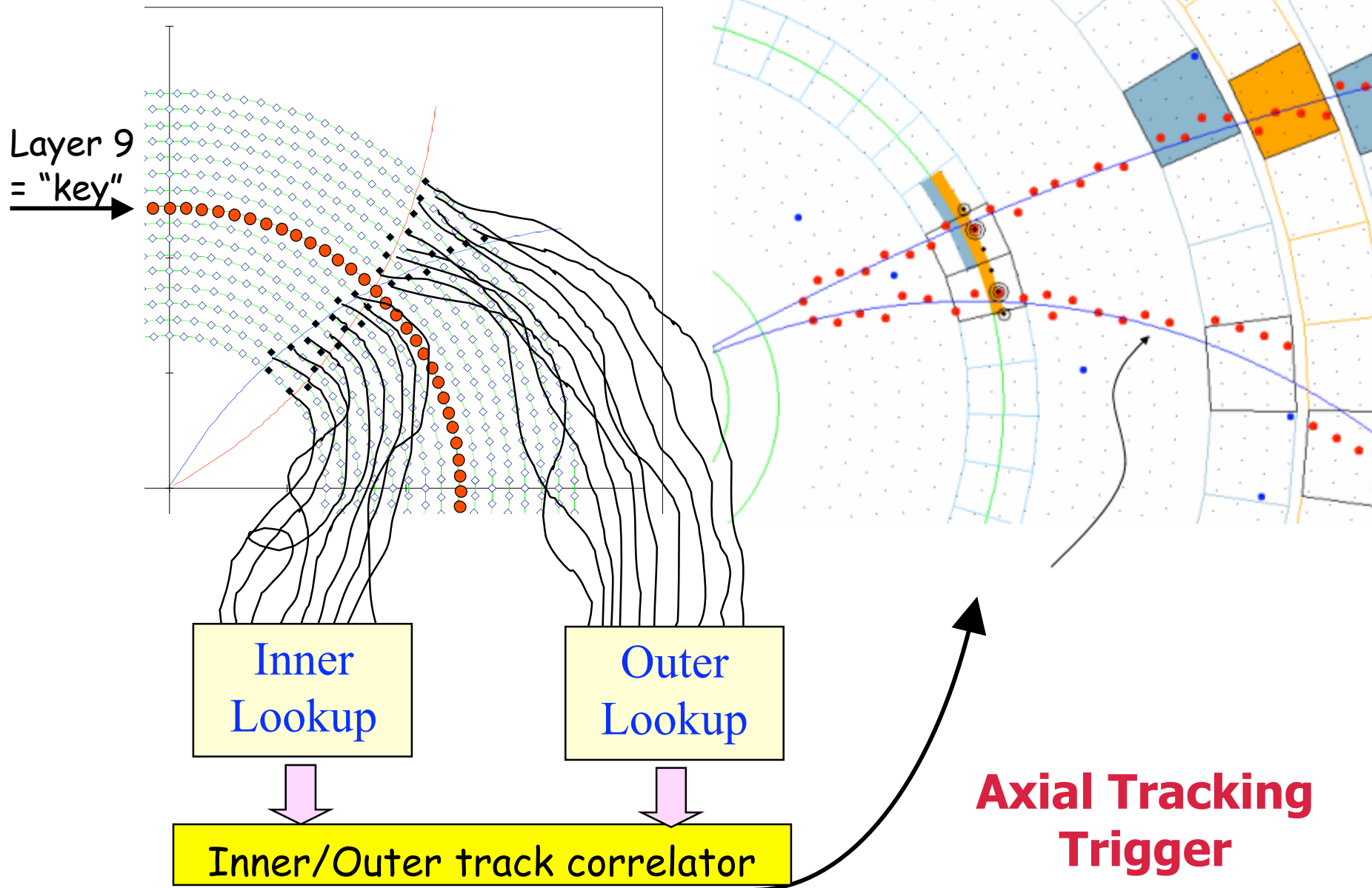

Stereo Tracking Trigger

Time	1	2	3	4	5	6	7	8	9	10	11	12	13	14	15	16	17	18	19	20
AI 1/7	1	2	3	4	5	6	7													
AO 1/9	1	2	3	4	5	6	7	8	9											
AW 2/3	67	68	69																	
UR 1/1	1																			
VR 1/1	1																			
UC 1/1	44																			
VC 1/1	48																			
Mode	0	1	2																	

There are too many wires to form all combinations in LUT

- Combine these into 4x4 blocks

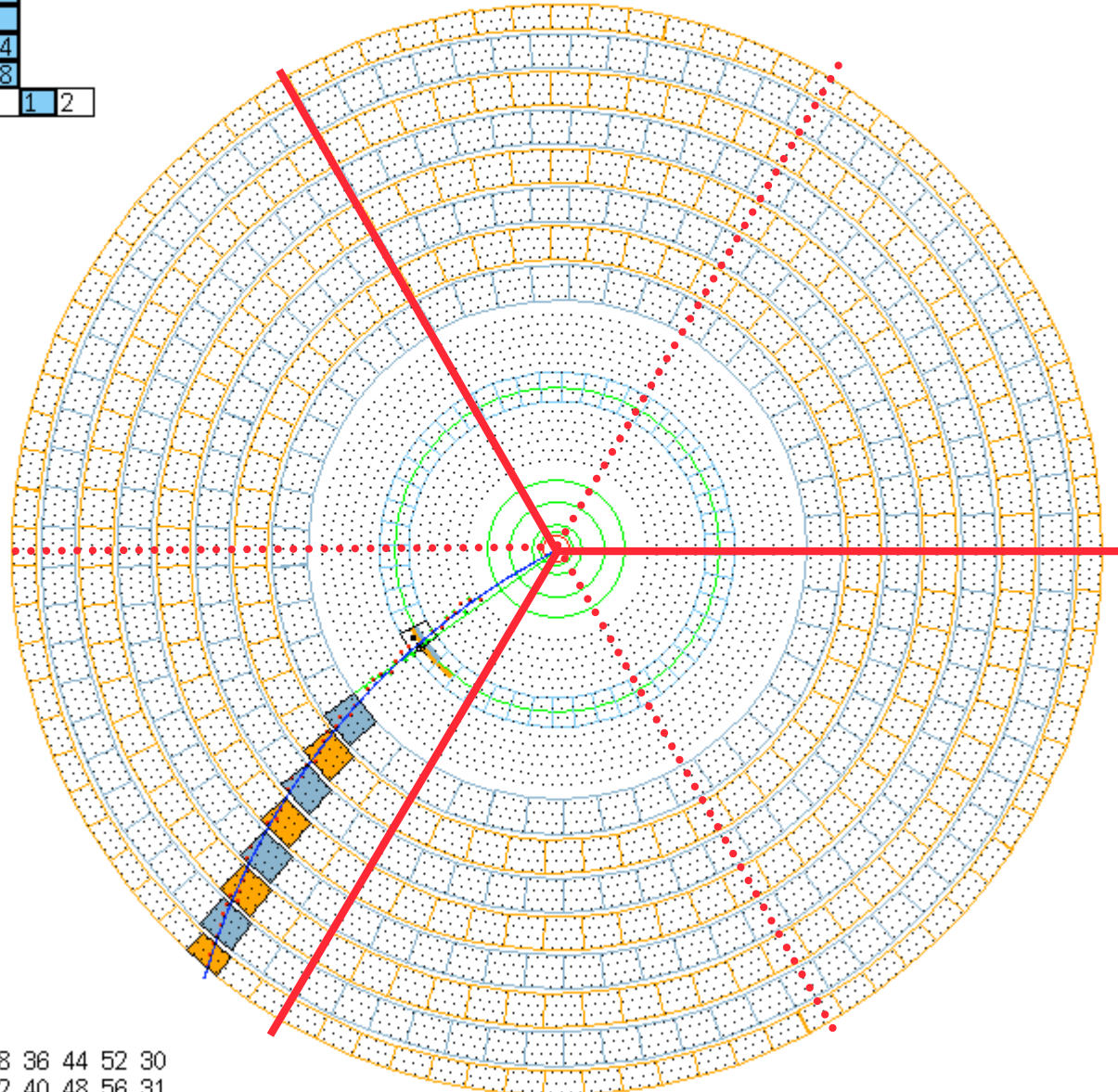

10 December 2006

U-Cells: 28 36 44 52 30
V-Cells: 32 40 48 56 31

Track in U and V Independently

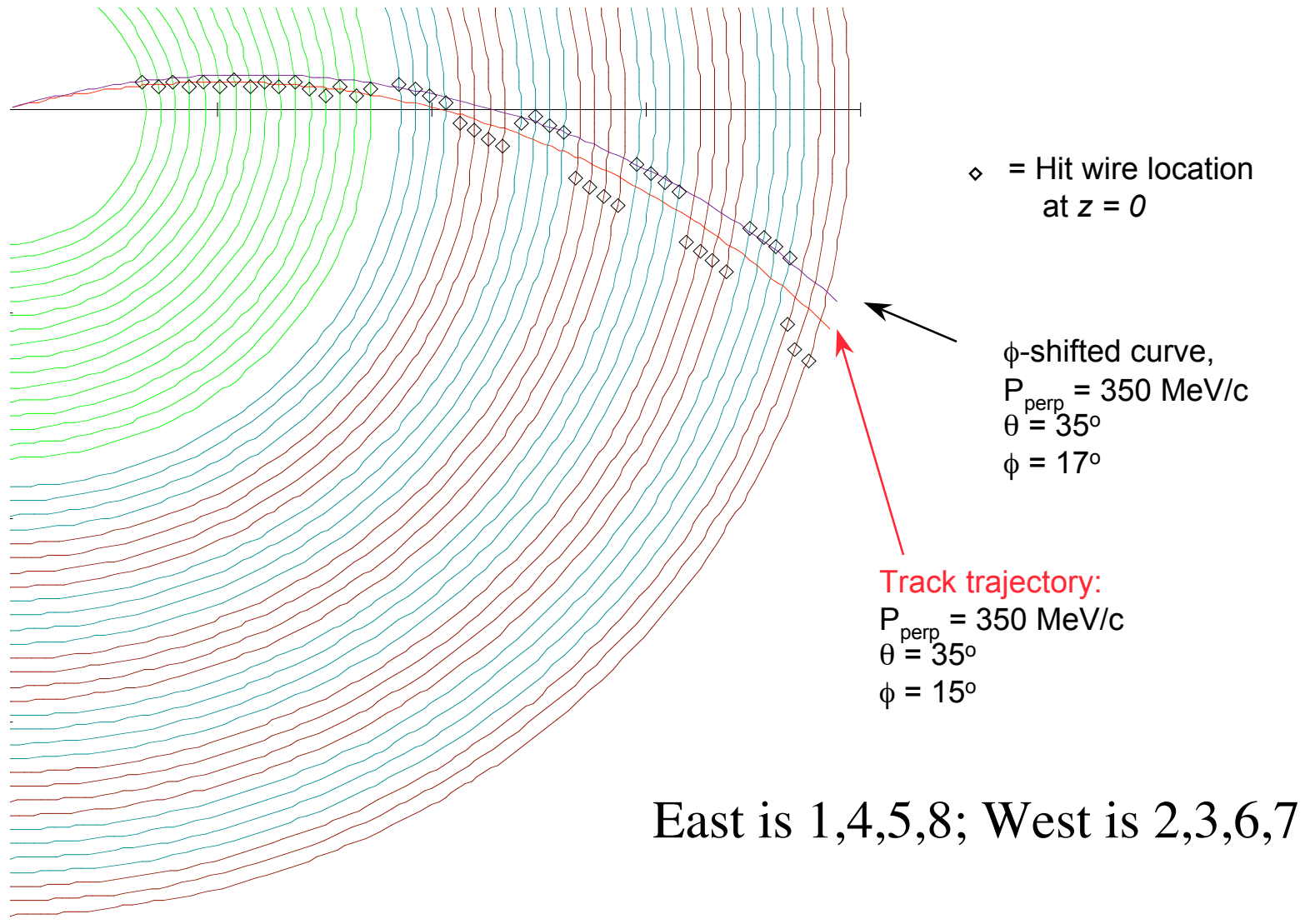

Axial – Stereo Correlation

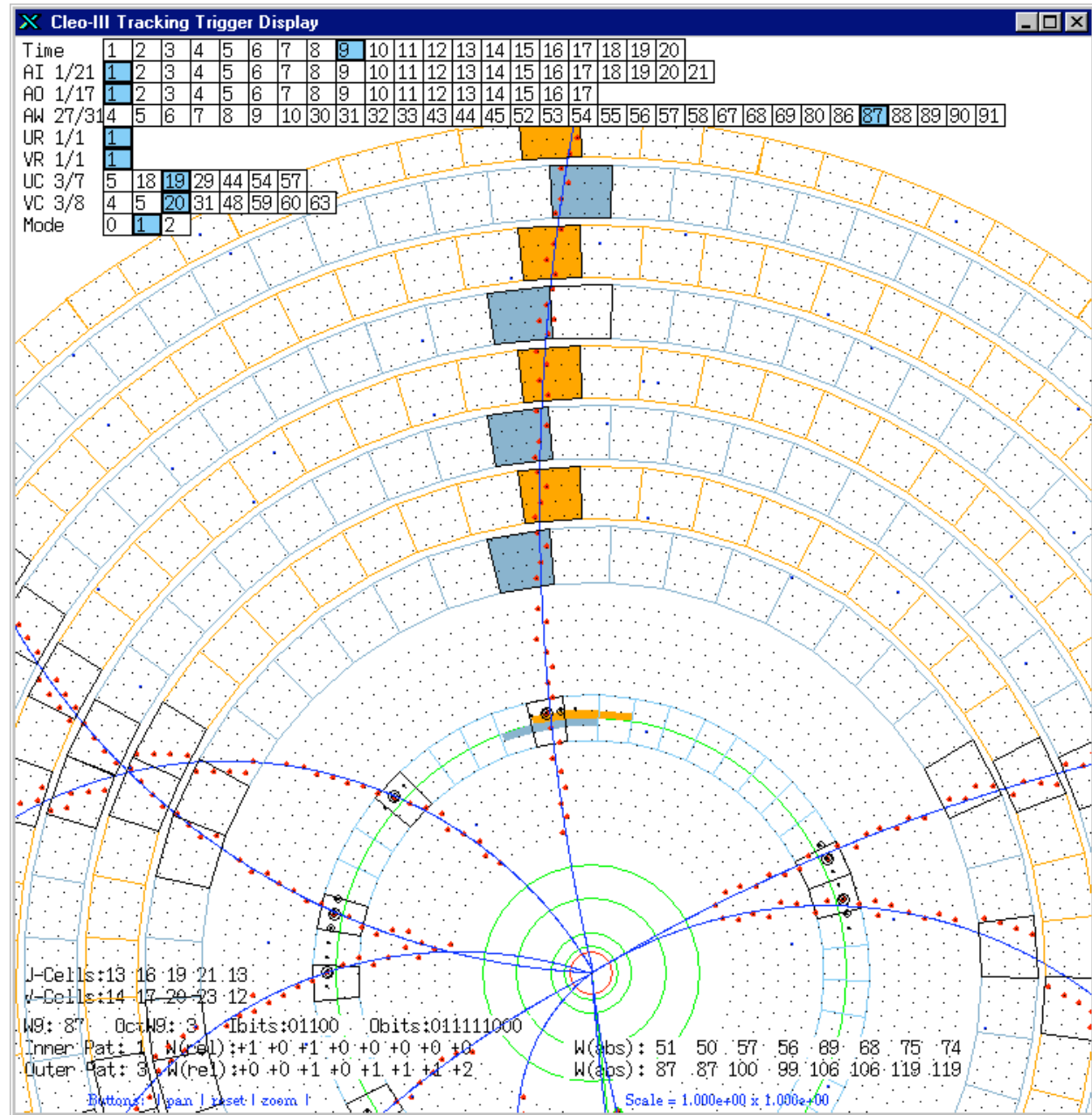

Tracking Systems at the ILC

Four competing detector “concepts” ... decision needed in 2010

Three of these “concepts” use a Time Projection Chamber to detect and measure charged particle trajectories.

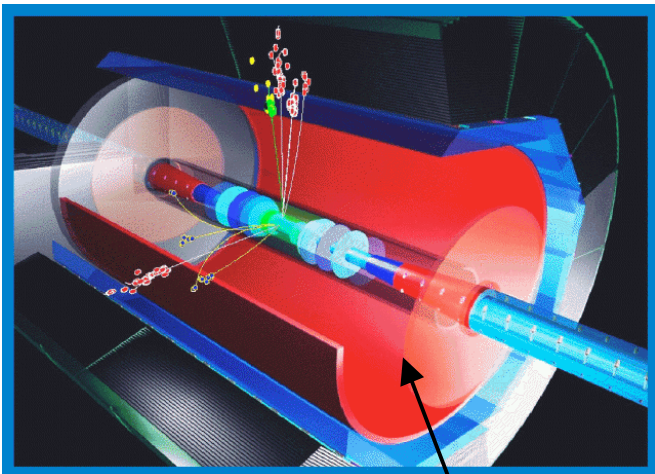

TPC

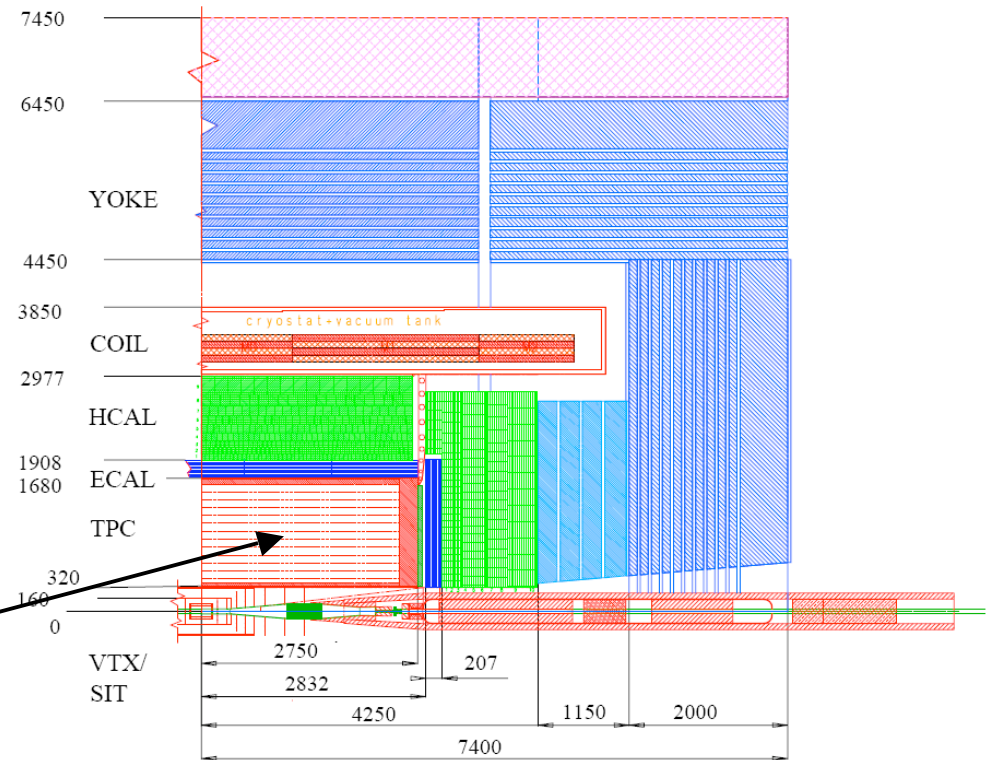

Time Projection Chamber: TPC

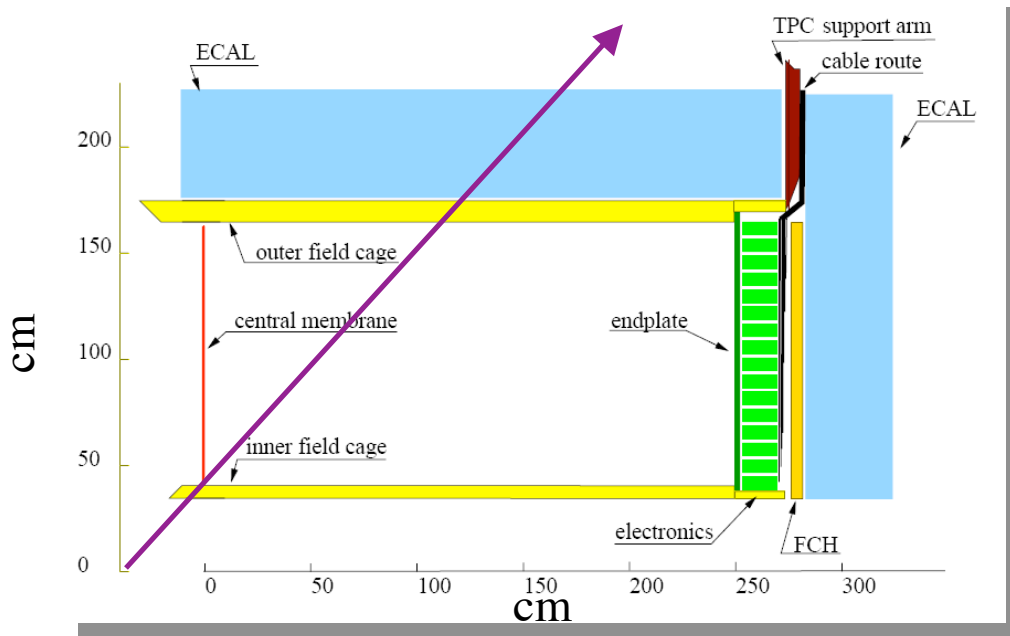

track goes through

gas is ionized

electrons drift ~ 2 m

gas-amplification device

signals on pads

drift time: z coordinate

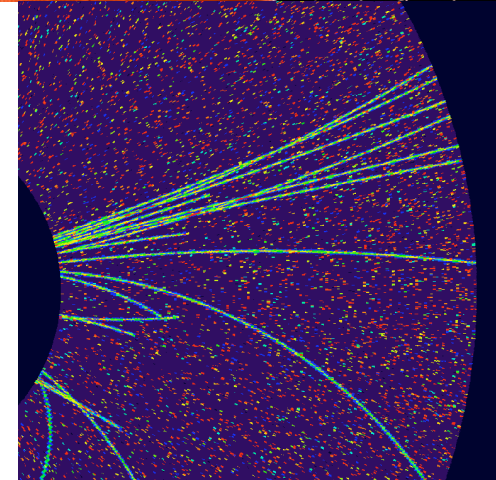

Small Scale Prototype TPC at Wilson Lab

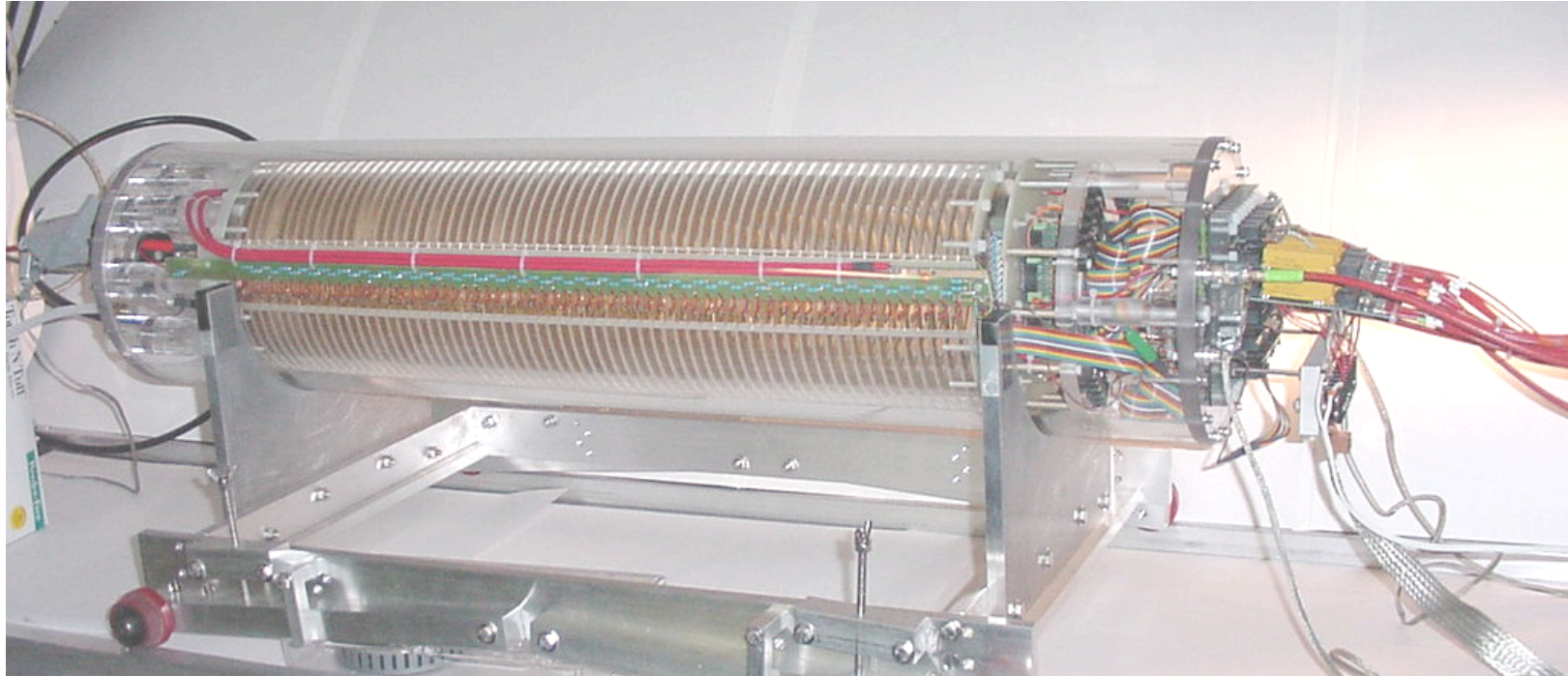

**Offers extremely flexible platform to test and optimize
MPGDs [GEMs and Micromegas]**

MPGDs from Purdue, industry, foreign collaborators

**Results feed into the simulations and large prototype
design**

Small Prototype Program at Wilson Lab

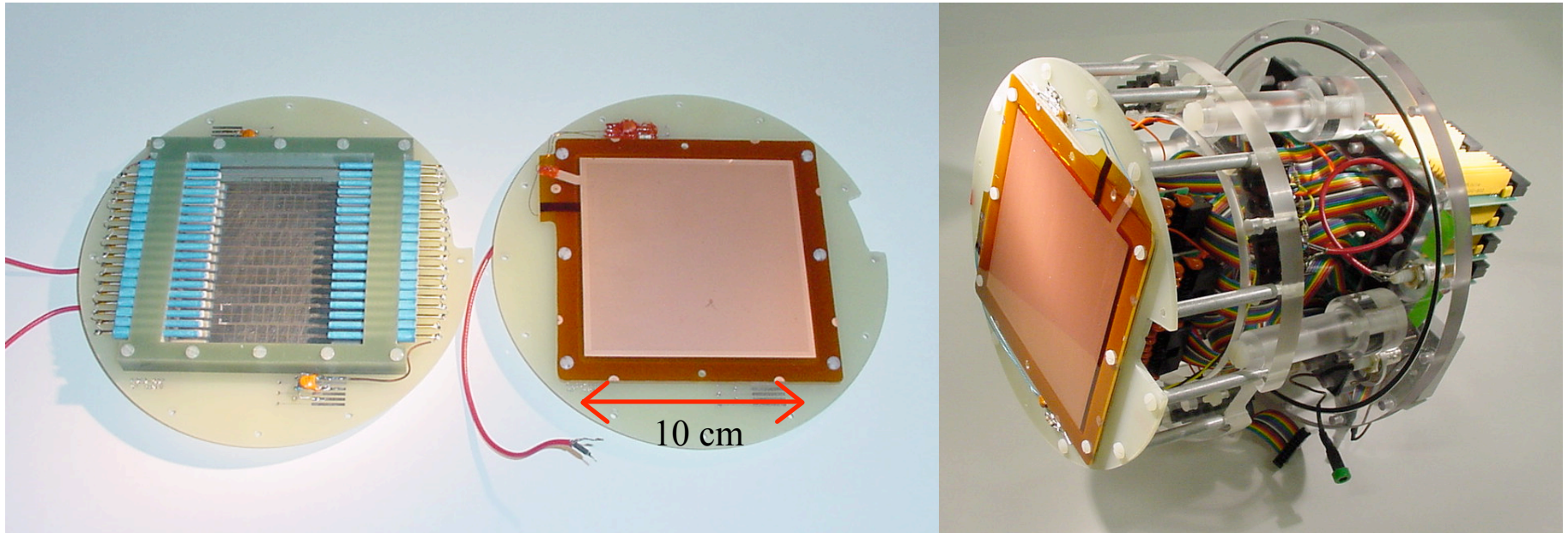

MWPC amplification
mounted on a pad board
(5mm x 10mm pads)

single-GEM amplification
mounted on a pad board
(5mm x 10mm pads)

readout module including
double-GEM amplification
mounted on a pad board

2005 - Demonstration data, taken with 5 mm width pads and 32 channels of FADC

2006 - With an increase to 56 channels, reconfigured pad layout with 2mm pads

Thanks also to Laura Fields and Peter Onyisi!

Ion Feedback Measurements

Positive ions are created during amplification and drift back into the field cage. (Not good.)

Ion feedback is expected to be suppressed with the GEM or Micromegas relative to MWPC.

If ion feedback is not sufficiently suppressed, a gating grid will be required (yuk!).

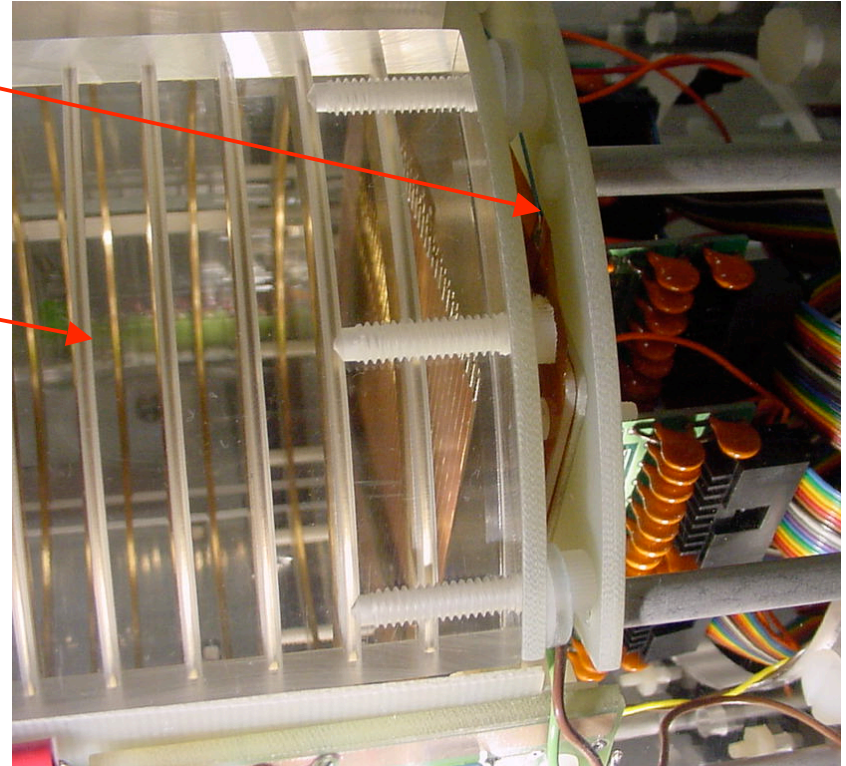

Also part of REU project of James Inman

Ion Feedback Detection

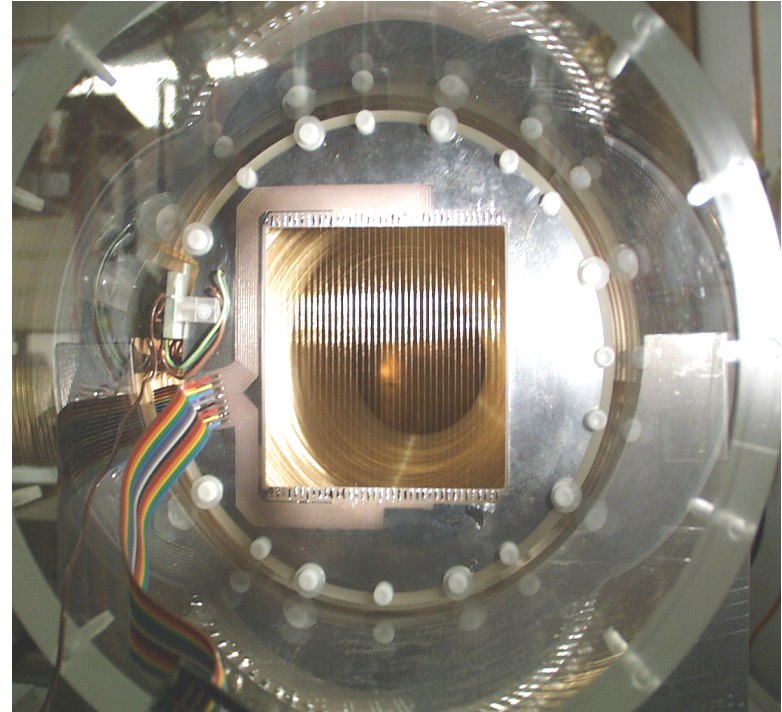

Positive ions are created during amplification and drift back into the field cage.

We measure the ions on the field cage termination plane, for individual tracks. A new double-layer termination plane allows biasing the read-out side to collect ions and uses 8 readout channels (5mm each)

The method differs from that used by Saclay/Orsay on MicroMegas and by Aachen on GEM, where a source was used to create ionization. Current was measured on the cathode.