

x-ray Beam Size Monitor

J. Alexander, N. Eggert, J. Flanagan, W. Hopkins,
B. Kreis, M. McDonald, D. Peterson, N. Rider

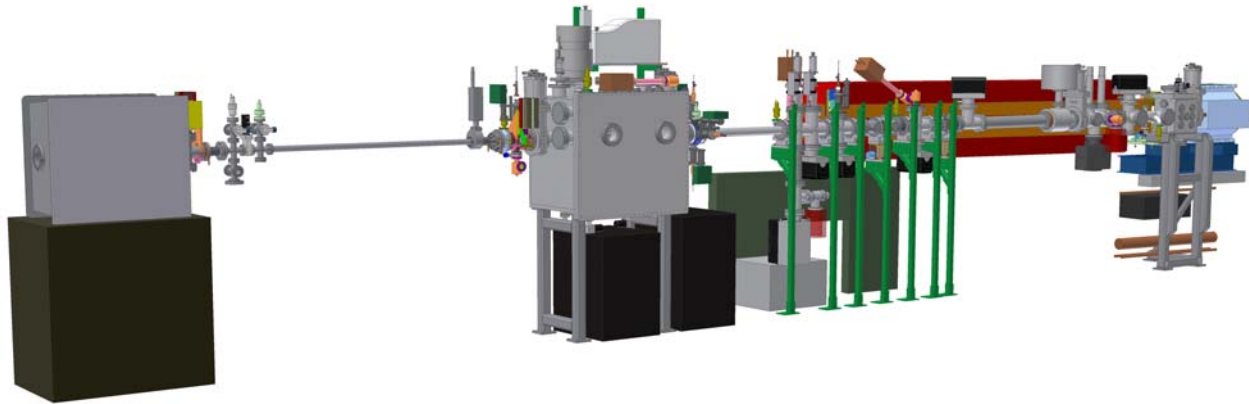

Goals: 2 products:

- tuning tool with rapid feedback of beam height during LET
- measurements of beam size evolution in response to beam characteristics

Outline:

- x-ray beam line and detector configuration
- detector details
- detector improvements for May 2009 run
- calibrations
- capabilities
- beam tuning product
- possible improvements
- future

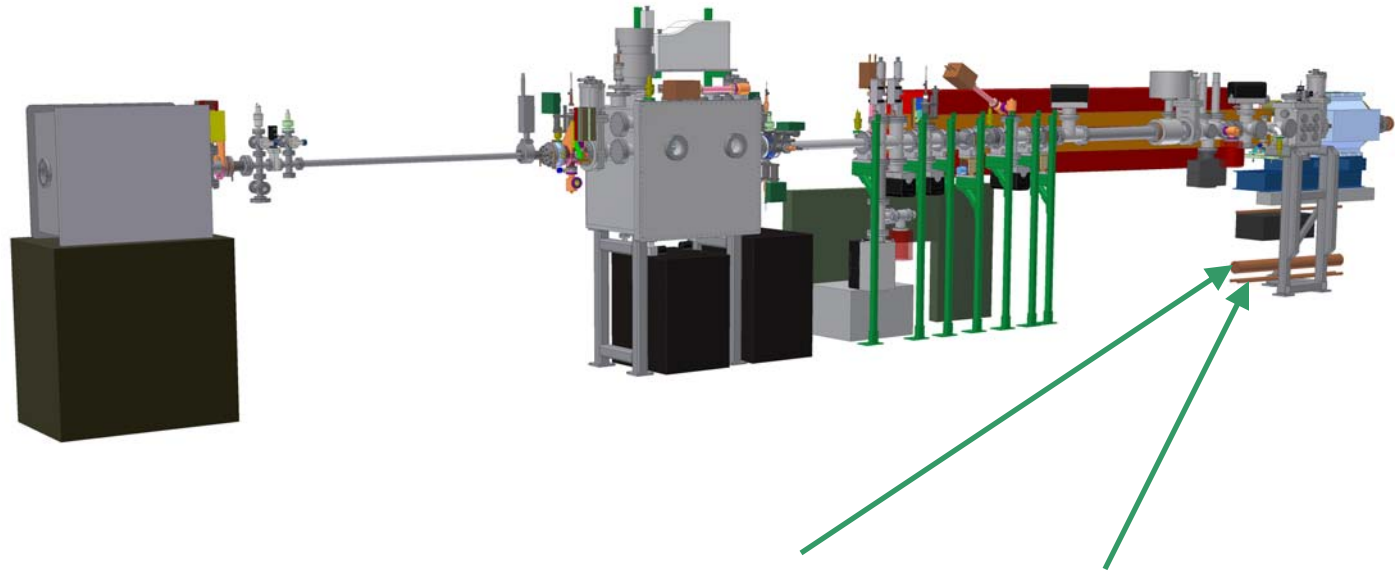

The x-ray optics assembly holds a chip with the optical elements.

There is currently a chip with 3 elements:

- square hole
- Coded Aperture (CA)
- Fresnel Zone Plate (FZP)

Each has a gross size of about 1mm.

There is also a vertically limiting adjustable slit.

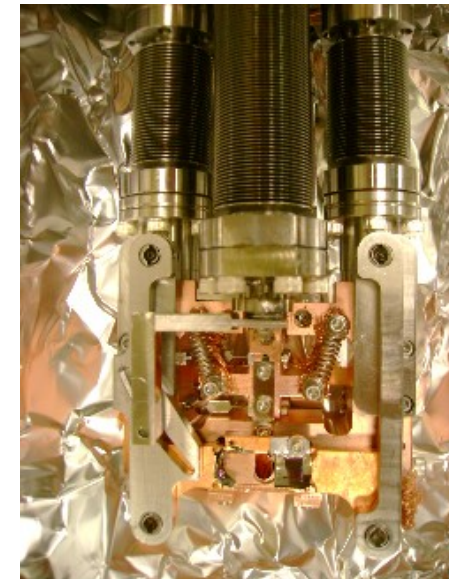
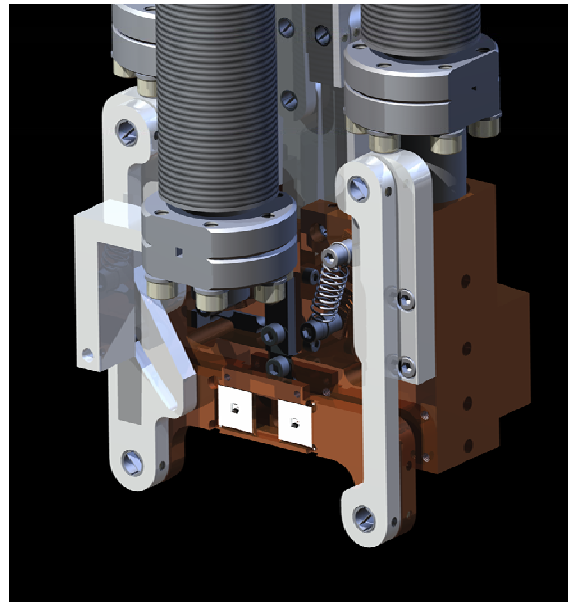

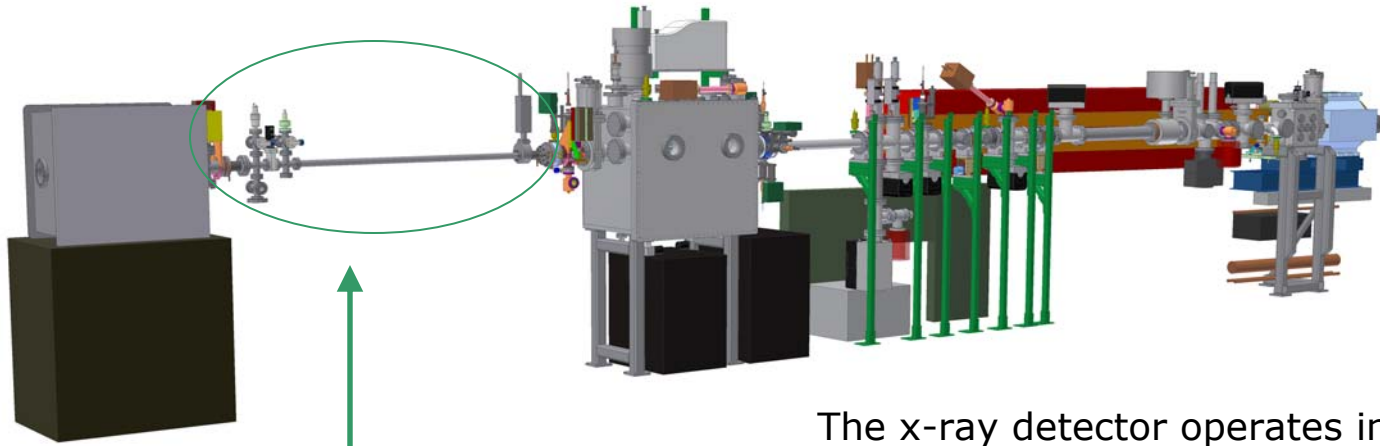

The x-ray detector operates in a vacuum, but must be isolated from the CCSR vacuum to avoid contamination of CCSR and allow quick-turnaround access to the detector.

The detector vacuum (~ 0.5 Torr) is isolated from the x-ray line vacuum ($\sim 10^{-6}$ Torr) by a diamond window (next slide).

The pressure difference across the diamond window is controlled by this system. Protection from a catastrophic failure is with a gate valve.

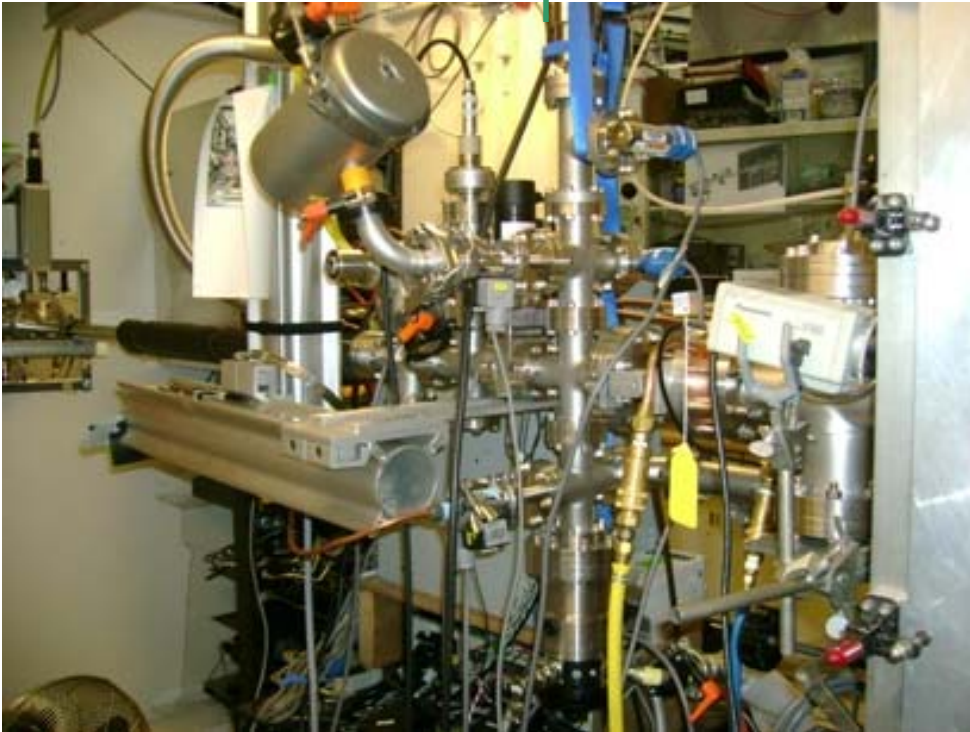

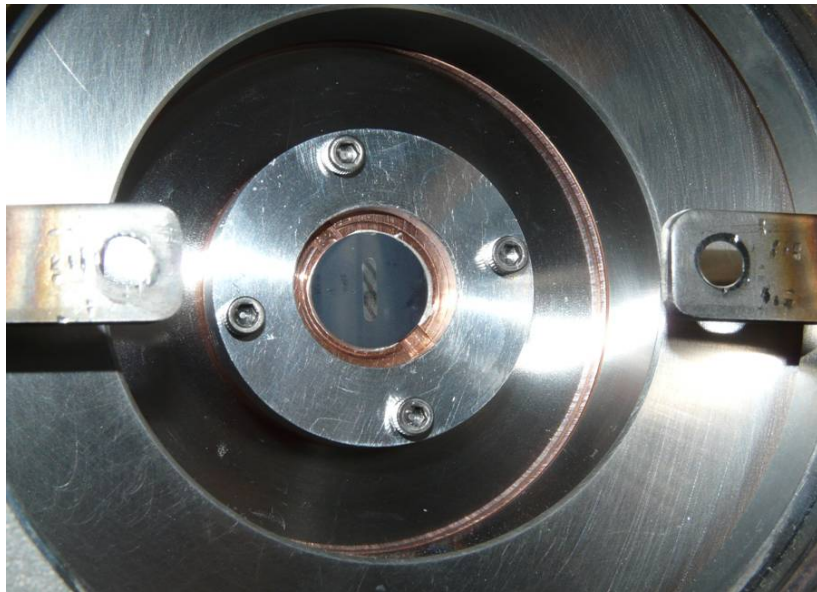
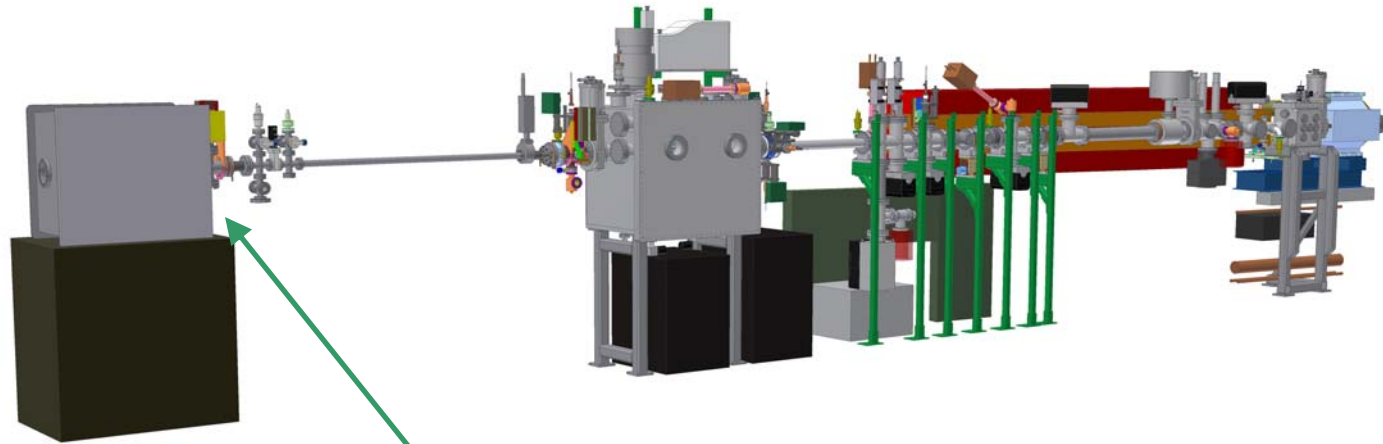

The thin (4 μ m) diamond window separates high quality CESR vacuum low quality vacuum of the detector enclosure.

The window transmits 76% of the x-rays at 2.5keV, and is supported by a thick silicon frame; the 4 μ m membrane region is 2mm (horizontal) x 6mm (vertical).

The window was fabricated by Diamond Materials GmbH of Freiburg

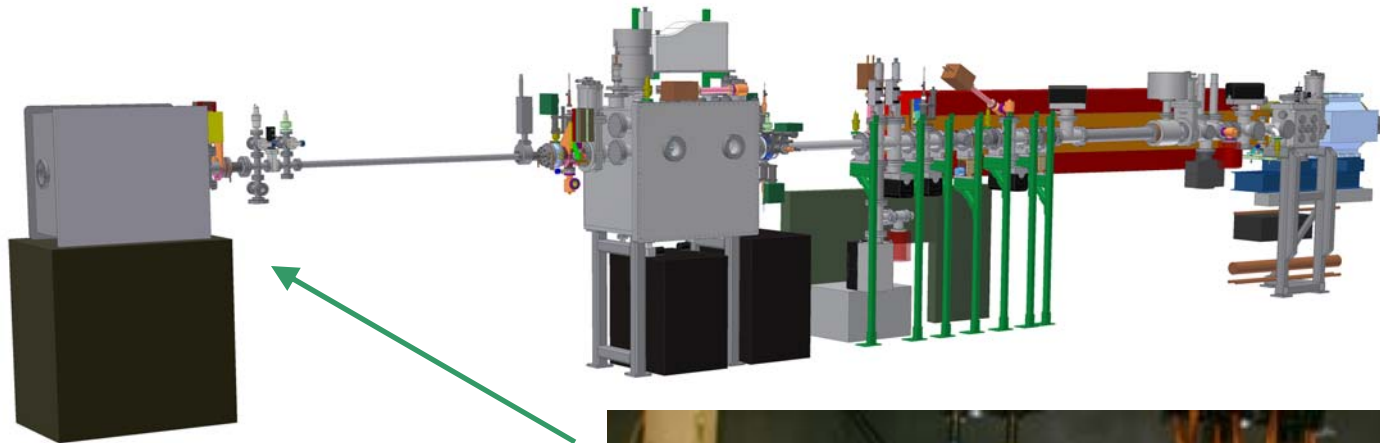

The detector box contains
movable slits for calibration, and the
diode array detector and preamplifiers.

The monochromator is a silicon-tungsten
multi-layer mirror.
X-ray energies are selected as a function
of angle with 1.5% FWHM bandwidth.
This well matched the chromatic
aberration of the 239 ring FZP.

All devices are motor controlled.

As this is in a vacuum, the amplifiers are
water-cooled.

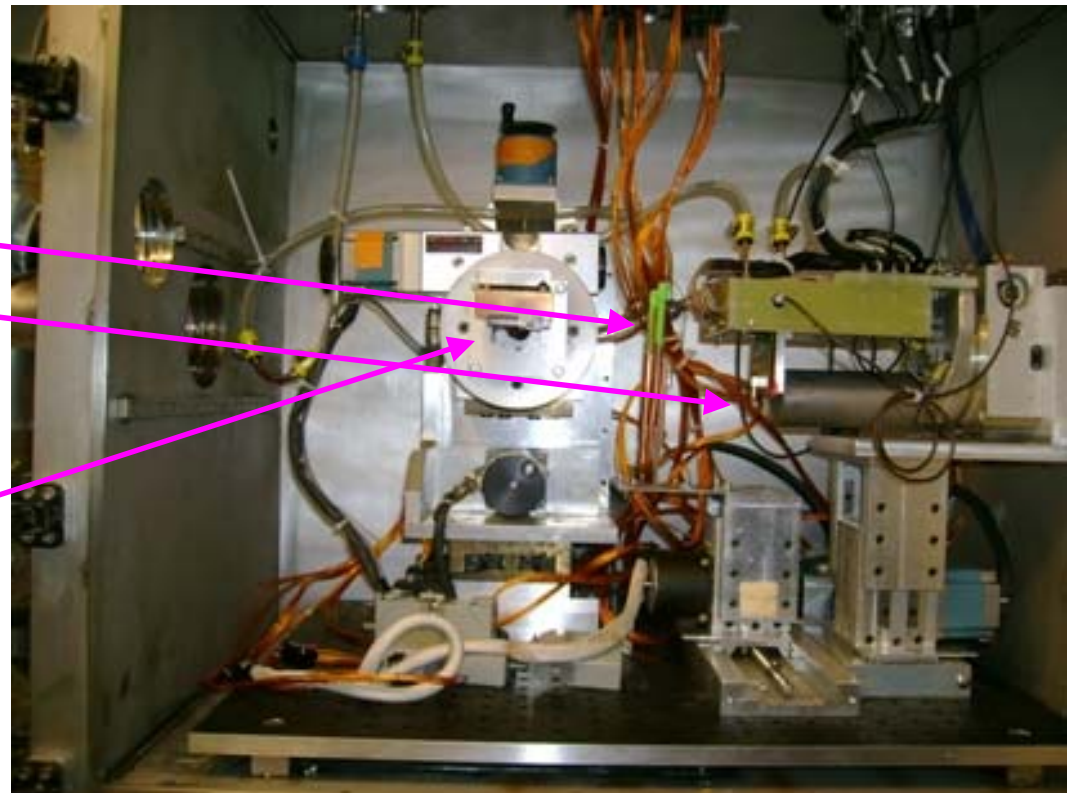

Detector:

an array of ~ 64 diodes, InGaAs, manufactured by Fermionics Inc.,
50 μm pitch (1.6mm coverage over 32 diodes),
400 μm pixel width.

The InGaAs layer is 3.5 μm and absorbs 73% of photons at 2.5keV.

We instrument 32 contiguous diodes for the fast readout, a FADC with 14ns repetition rate.

There are also 8 diodes connected for the "DC" readout.

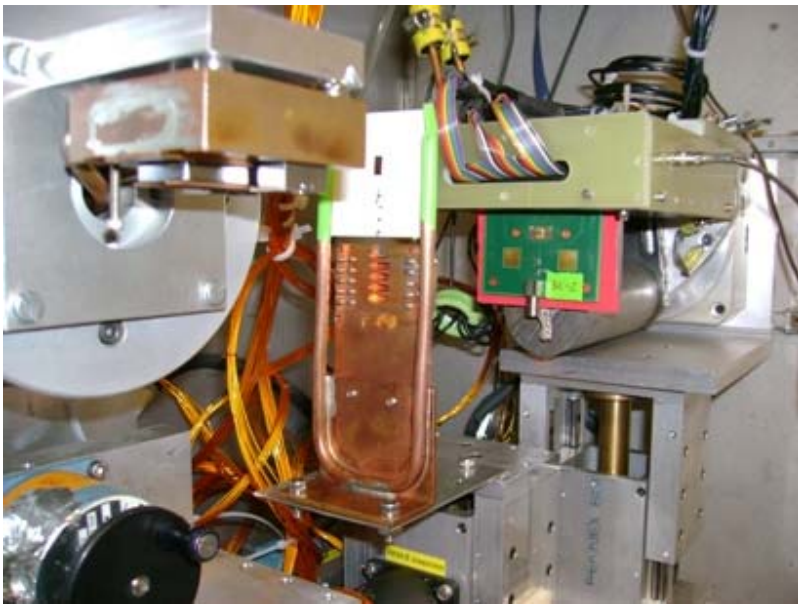

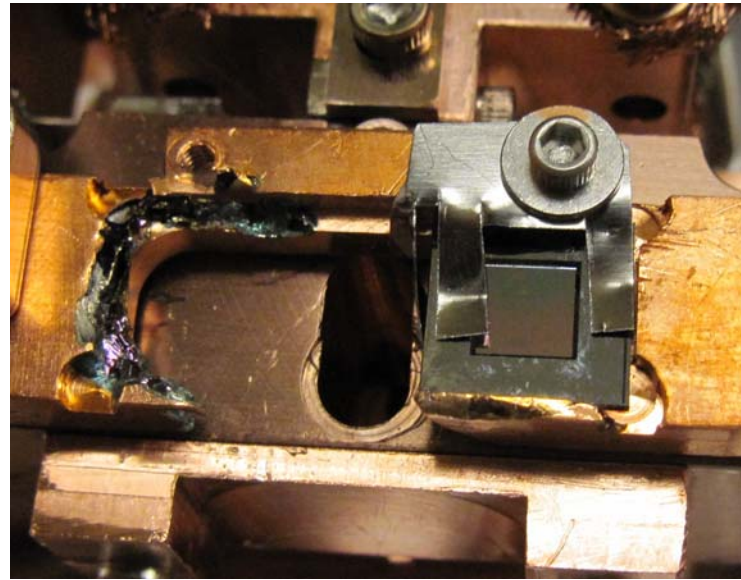
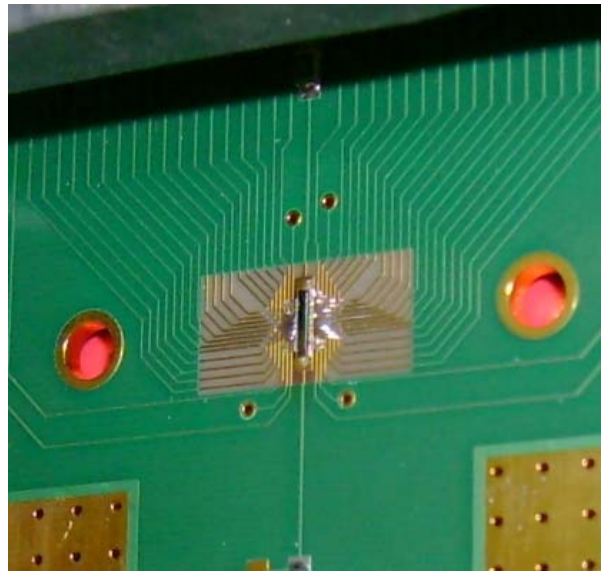
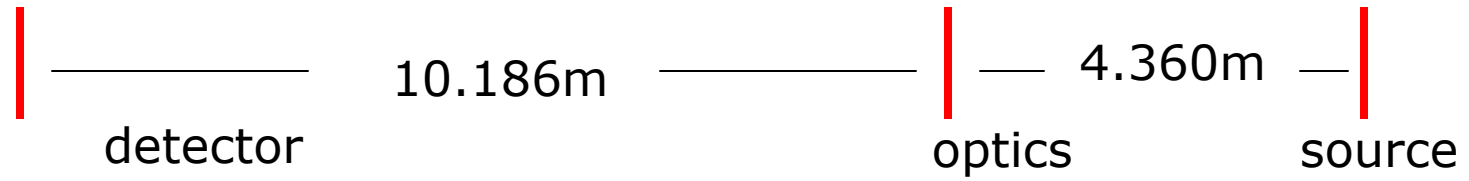
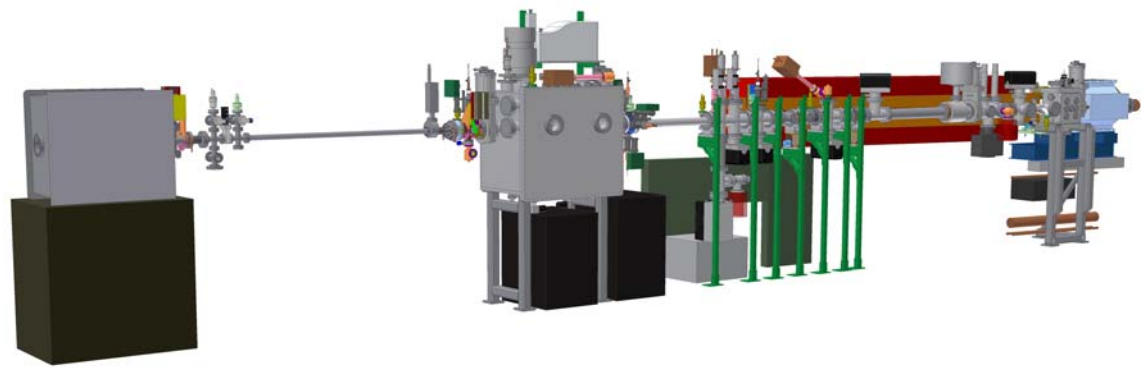

magnification: image/source size = 2.34

This shows the typical output of the "fast" and "DC readouts.

The "fast" readout uses 32 contiguous diodes, instrumented with preamplifiers, a shaping circuit and 14ns FADCs.

The array is in a fixed position during readout. Readout is synchronized to the bunch crossing to measure the peak of the response.

The image is observed by the relative response of the 32 diodes.

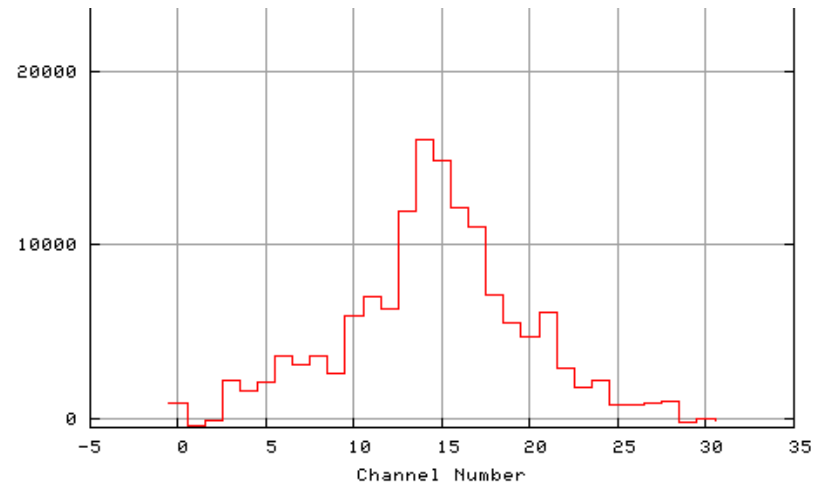

this is turn average response
32 diodes, FZP, monochrometer,
20090525-2368

In the "DC" readout, one of the 8 instrumented diodes is read directly through a pico-ammeter.

The ammeter output is collected, synchronized to the motion of any of the available motions.

In this case, the response is w.r.t. the vertical motion of the detector stage.

Thus, the single diode is swept through the x-ray image.

Integration is ~ 0.1 sec, the step size is typically less than a diode pitch.

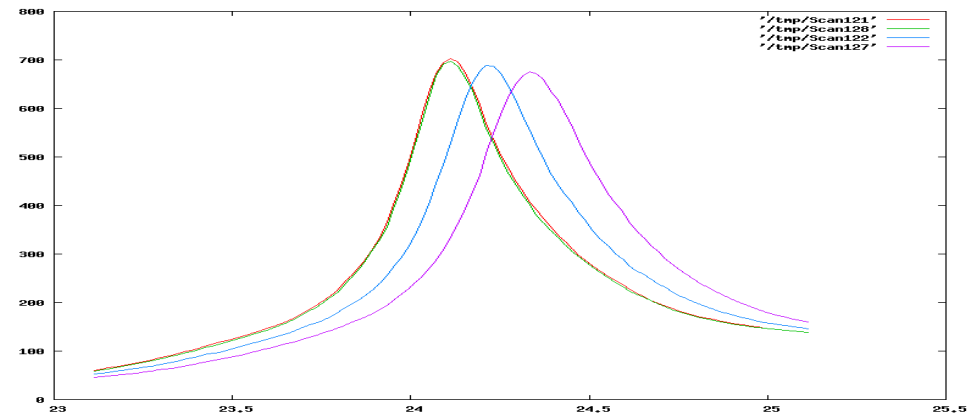

this is a slow scan of 1 diode,
TADETZ, 2mm motion, FZP, no-mono
20090201

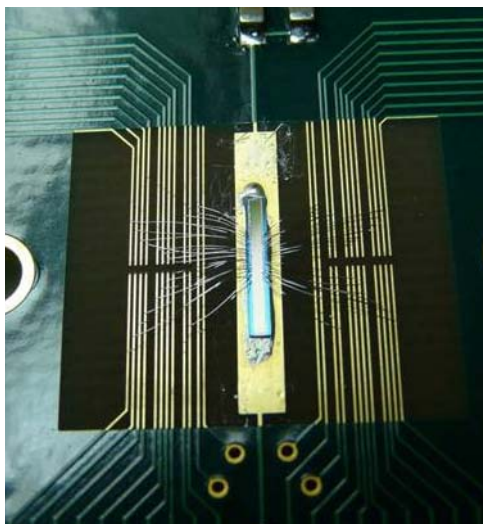

May 2009 run

Wire Bonding improvement

bonding efficiency

before: ~25% (above)

after:

tested 4 boards, all have
perfect 32 diode arrays

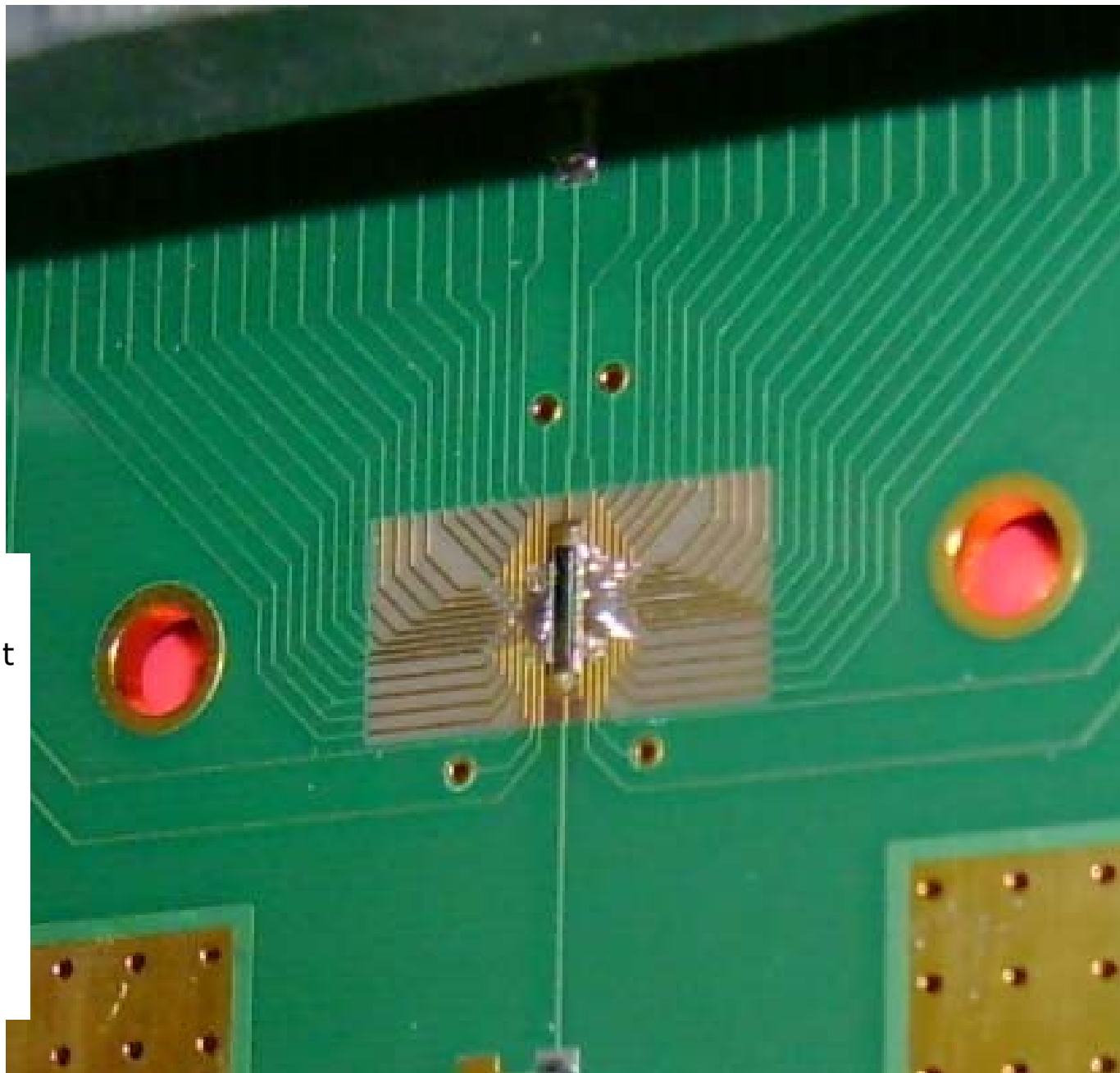

Improvements to the fast readout amplifier for the May run

Shaping was optimized as shown in the figures.

The noise reduction is grounding seen in slide 5.

Fermionics
"no shaping"

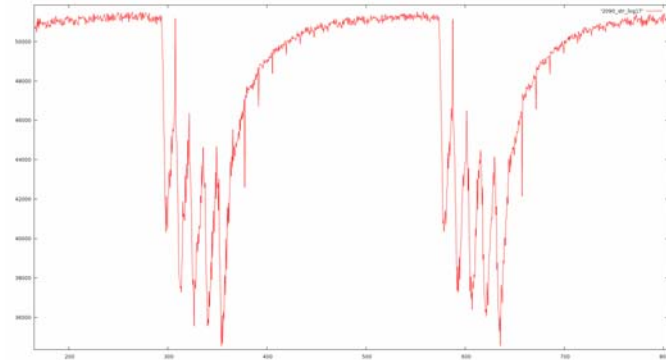

Fermionics
"39pF shaping"
as in January run

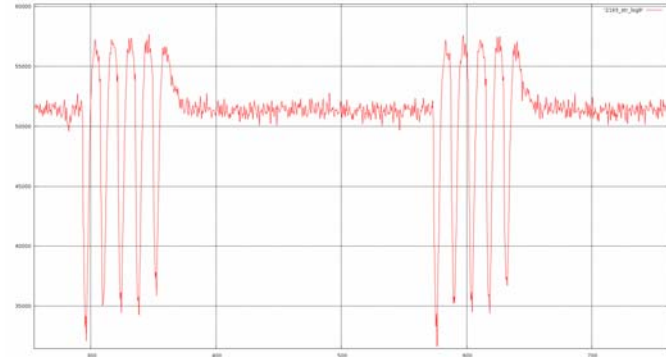

These are so-called "storage oscilloscope runs"; a readout of 1 diode array element is read during many CESR turns with phase advancing 0.5ns / turn .

Fermionics
"150pF shaping"
May run

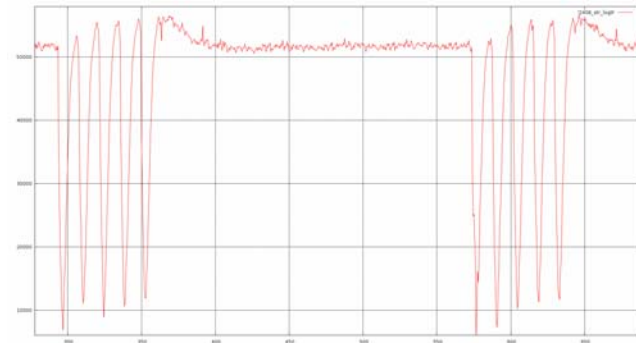

Mapping was first mapping done "by hand".

Use narrow focus FZP with monochrometer.

Scan the "fast" readout array across image.
Locate array elements with strong signal at each vertical location of the illumination.

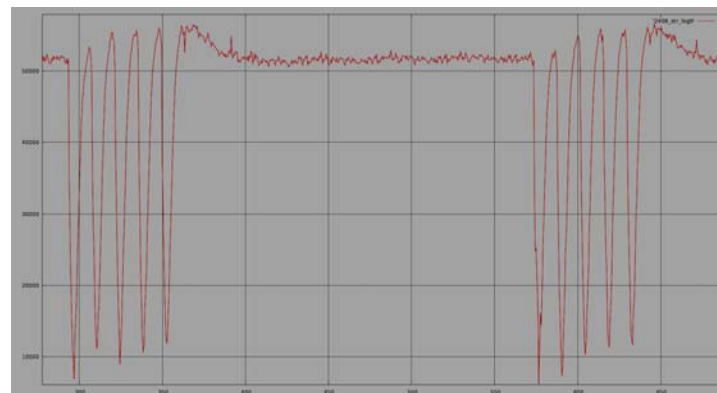

Determine the physical order of the logical channels.

Mapping was later automated, four detector boards mapped and certified

There is also a channel-to-channel PH calibration based on the observed signal.

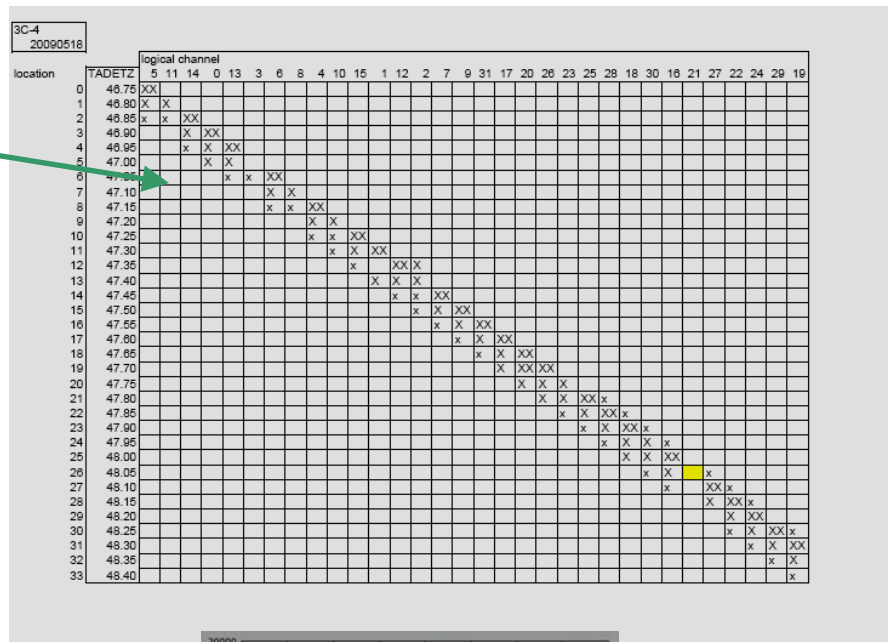

This shows the first evidence that the PH and mapping calibrations were working.

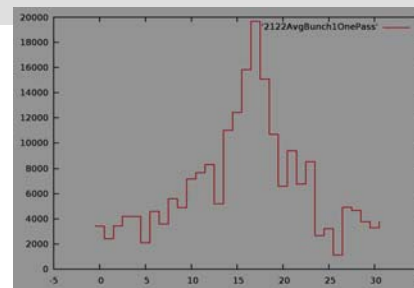

The monochrometer is used to mask the chromatic aberration of the FZP; it greatly decreases the image width, thus improving the spatial resolution of the detector.

On 20090525, we measured the number of photons reaching the detector by comparing the mean and variation of the PH in the peak channel.

Using the FZP monochrometer, 1 bunch, 4.3ma.

The observed rate is about 1 photon/(ma of beam) at the peak.

Crisis: We will never have enough photons to use the monochrometer in one-turn measurements.

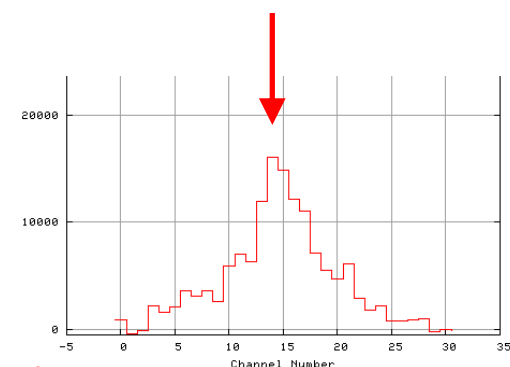

a turn-averaged response
32 diodes
FZP, monochrometer

We investigated the use of white-beam.

The image will be a convolution of x-ray energies, with varying amount of defocus.

20090529: Using the "DC" readout, and a controlled increase in the beam size, we compared the sensitivity of white-beam measurements w.r.t. monochromatic beam, Using FZP, monochrometer, FWHM changes from .21 to .25mm
FZP and white-beam, FWHM changes from .46 to .50mm.
The relative photon count, at the peak, is 114.

20090601: We verified that the fast readout shape matches the "DC" readout.

Lesson: we can develop the measurement with white-beam.

20090601: Measured the beam position and image size for 10000 consecutive turns, single bunch beam structure.

The measurement is based on fits to the image, as observed in a single turn, with the fast readout. (At this point, it is a simple gaussian fit.)

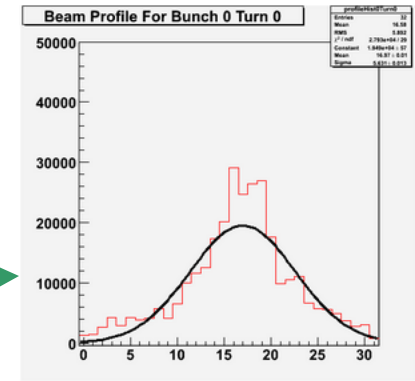

The history of the image position over 10,000 measurements, 0.0256 seconds, shows a disturbance initiated at 60 Hz, with amplitude of 150 μm .

The image position measurement accuracy is $\sigma < 35 \mu\text{m}$, as indicated by the narrowest part of the wave form.

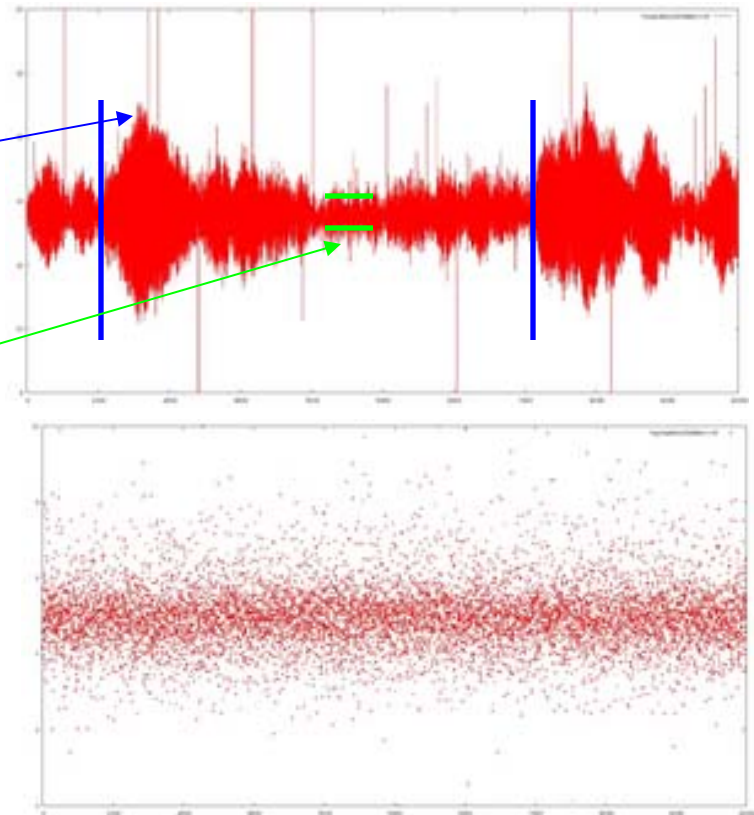

The history of the image size does not show a correlation with the variation of the position. While the image shape has $\sigma = 250 \mu\text{m}$, the variation of the image shape is $\sigma_{\sigma} \sim 35 \mu\text{m}$.

(Based on the slow diode measurements 20090531, we expect σ (image shape) = 230 μm .)

A Fourier analysis of the
position disturbance

reveals the betatron frequency
 ~ 142 kHz

and the synchrotron frequency
 ~ 20 kHz.

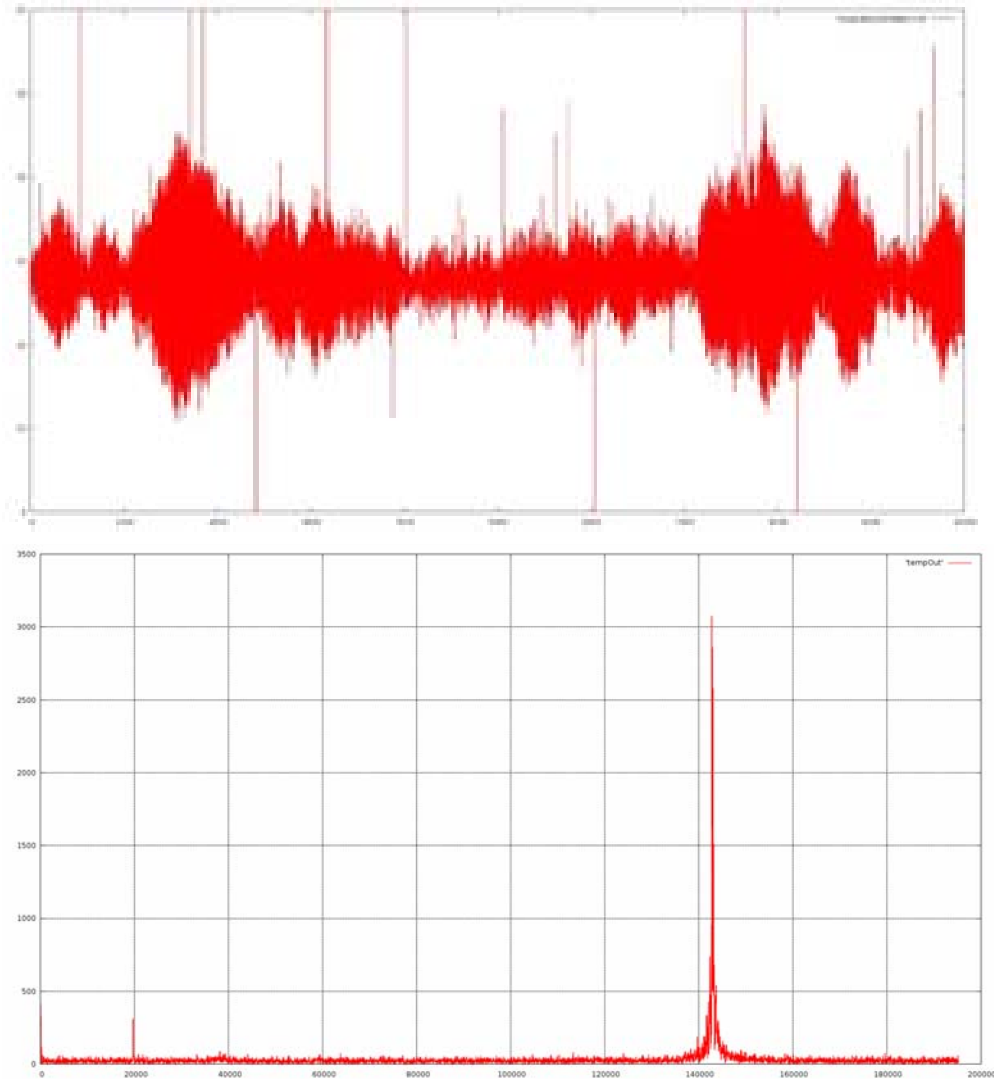

The “tuning tool” (one of our goals) is a chart recorder of the beam size and position that gives feedback to the CESR tuner.

We require a faster and stable calculation method for the “tuning tool” display.

Sum distributions from 100 turns.
Fit the sum to a gaussian,
then refit with 2nd iteration within $\pm 2\sigma$.

With this, we define a window, $FW=4\sigma$,
for determining center and RMS for individual turns.

The window is the same for all turns.

Positions are averaged over the 100 turns.

Beam sizes (rms), now de-convolved from the position,
are averaged over the 100 turns.

Update time is ~ 2 seconds.

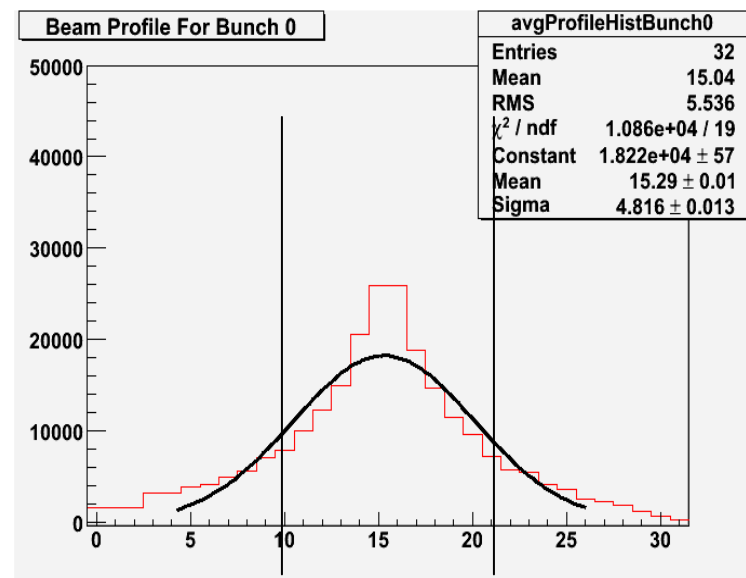

(The saved data is more coarse than during measurements.)

20090612, ~22:15

we varied

β_{sing1}	position μm	size (σ) μm
0	118	175
100	60	185
300	-360	192
-100	210	190
-200	330	210

Beam position changes matched earlier observations with the DC readout.

Scatter in the beam position and beam size are both $\sim \pm 10 \mu\text{m}$.

The scatter in the beam size is improved relative to the single turn measurements by averaging.

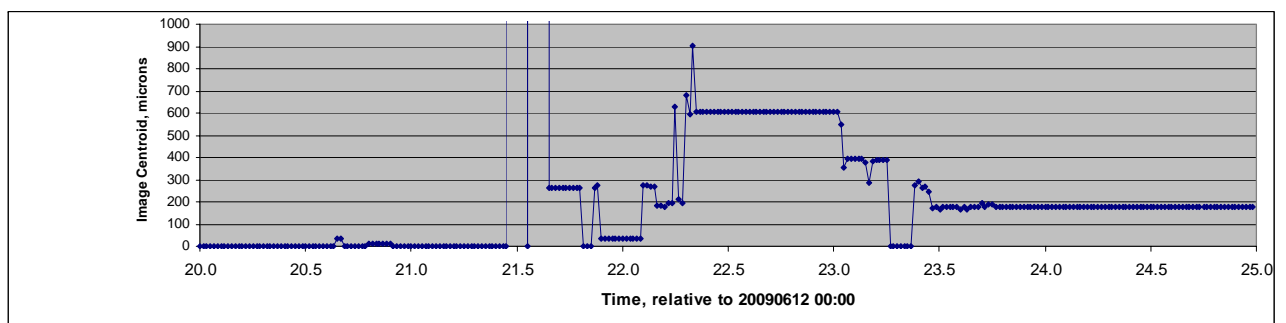
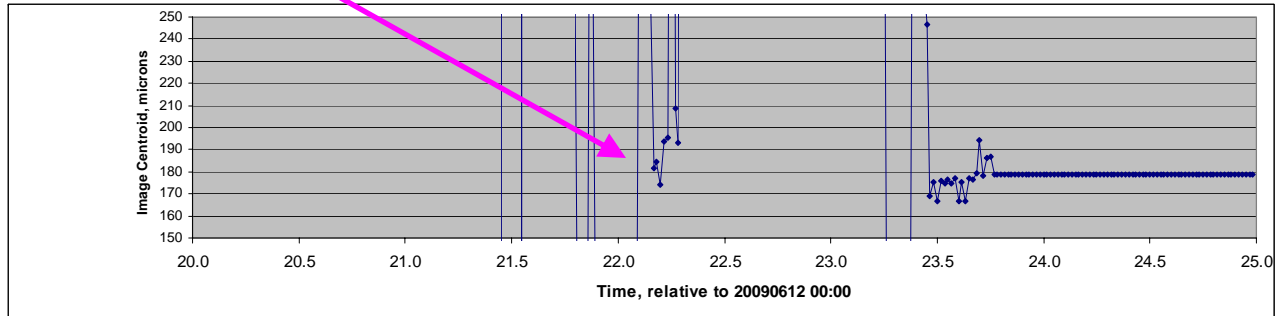
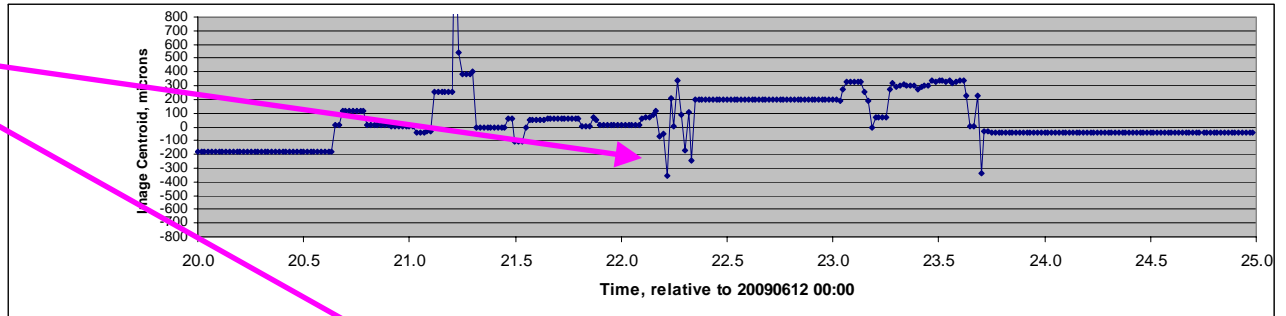
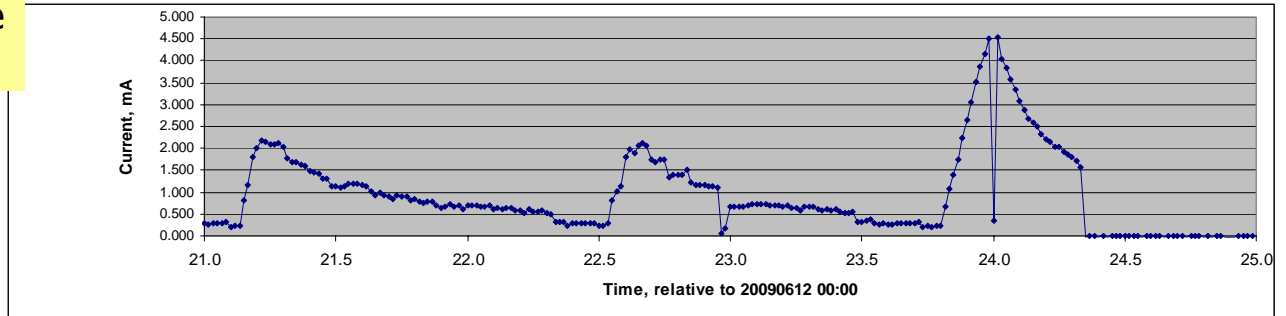

Next,
measure size change
over ~ 20 bunches.

We can configure to measure
20 bunches in one turn.

But, the turn would be
asynchronous with the vertical
modulation (below).

We can collect and average a total
of 10,000 bunch measurements.

That would be exhausted in only
500 turns, still not covering a full
period of the vertical modulation.

To properly average,
must reconfigure to
(collect 20 bunches in one turn,
wait 129 turns)
repeat 50 times.

Requires DAQ box software mods.

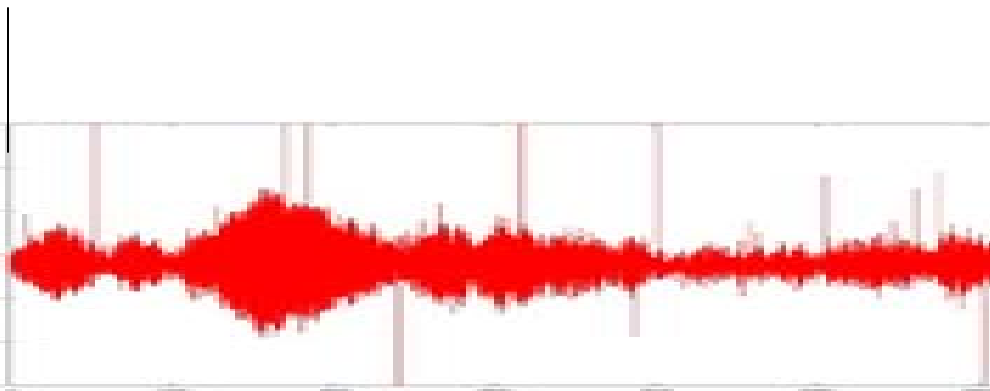
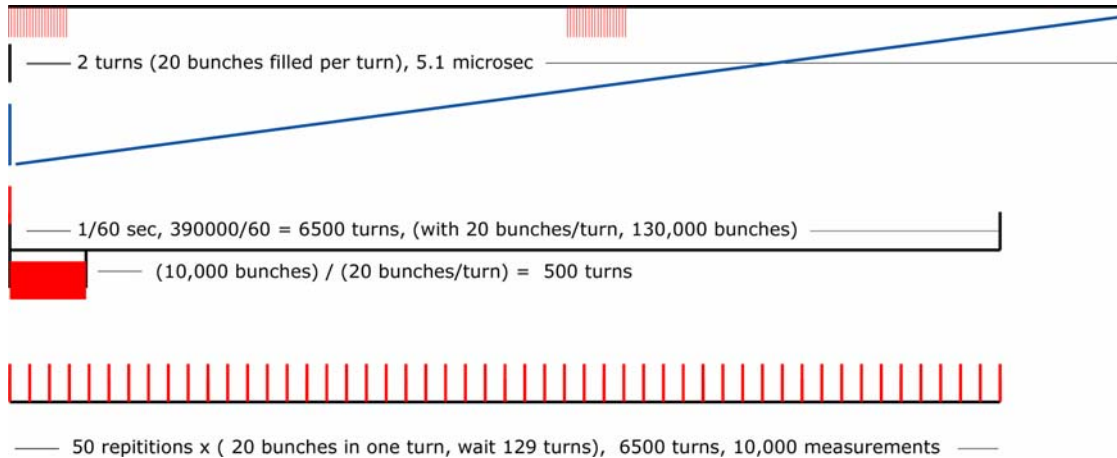

We are investigating the possibility that using the Coded Aperture, rather than the FZP, will lead to an improvement in resolution.

Shown are observed slow-scan distributions for the FZP and CA.

We create a controlled beam size change with β_{sing1} . "Blue" is for $\beta_{sing1}=+0$; "pink" is for $\beta_{sing1}=+100$. In the case of the FZP, $\Gamma=313$ and $368\mu\text{m}$ at the image.

The peak of the FZP distribution, $\beta_{sing1}=+0$, is arbitrarily set to a value of 1. The CA distribution, $\beta_{sing1}=+0$, is beam-current normalized to the FZP.

In each case (FZP and CA) the $\beta_{sing1}=+100$ scan is area normalized to the corresponding $\beta_{sing1}=+0$ scan. This is how I would normalize when template-fitting.

I calculate, over a width of 1.6mm, the rms of $((PH(\beta_{sing1}=+100)-PH(\beta_{sing1}=+0))/\sigma$, where $\sigma=PH(\beta_{sing1}=+0)1/2$,

rms(CA) / rms(FZP) = 1.7

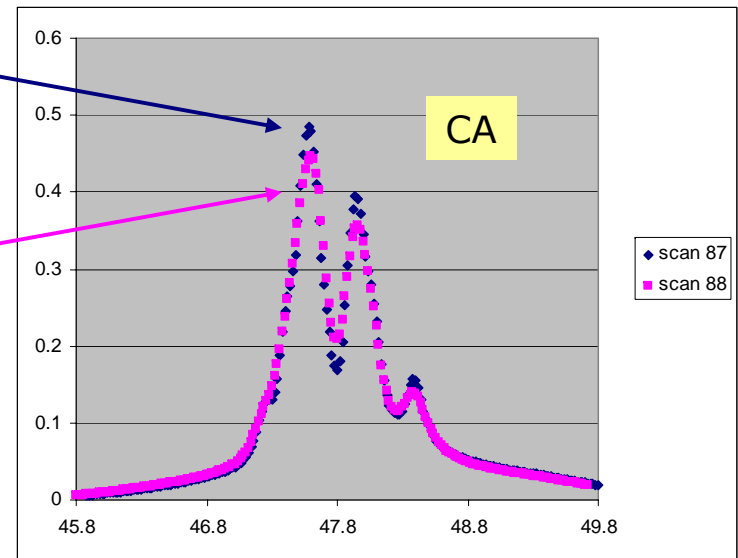
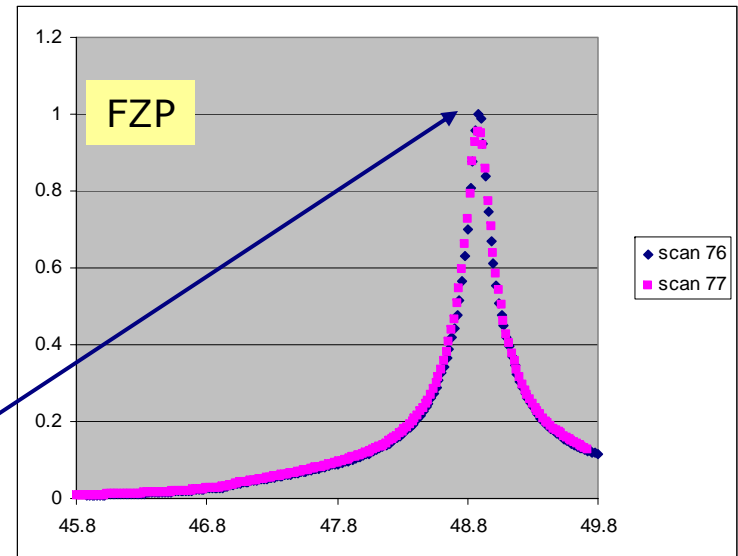

20090606

Based on the expected improvement, we will investigate further. The CA distribution uses all of the diode array and will require continuous alignment.

The 4ns FADC readout is under development.

Tests were made during 2 shifts of the May 2009 run.

We uncovered 2 areas needing work:

noise (related to the required speed),

timing jitter.

(The shape is due to the currently used amplifiers and shaping.)

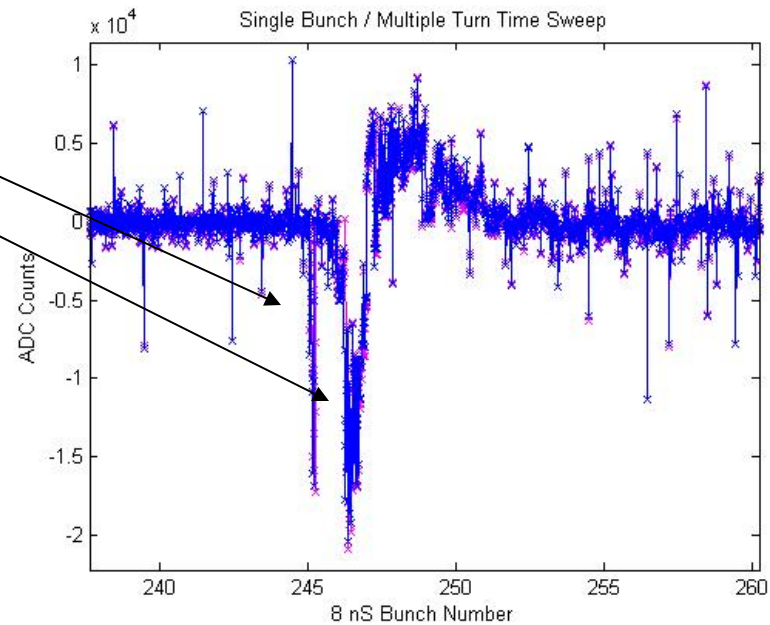
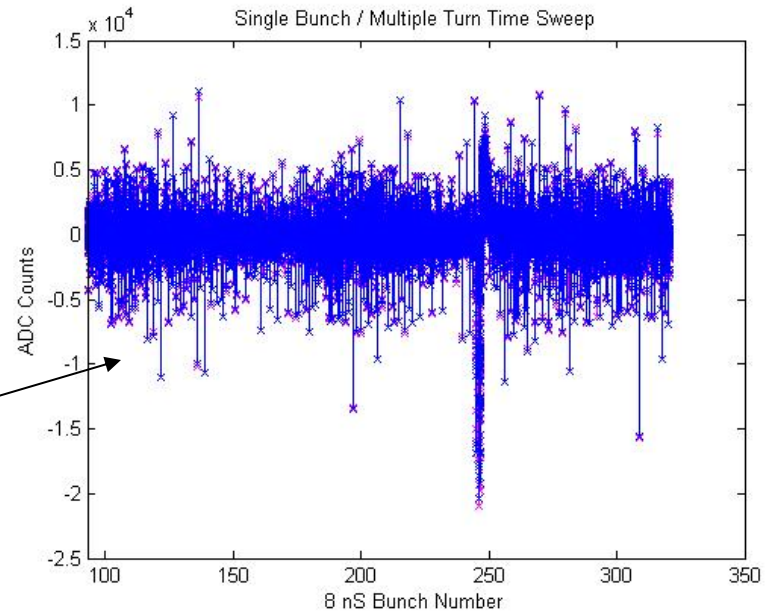

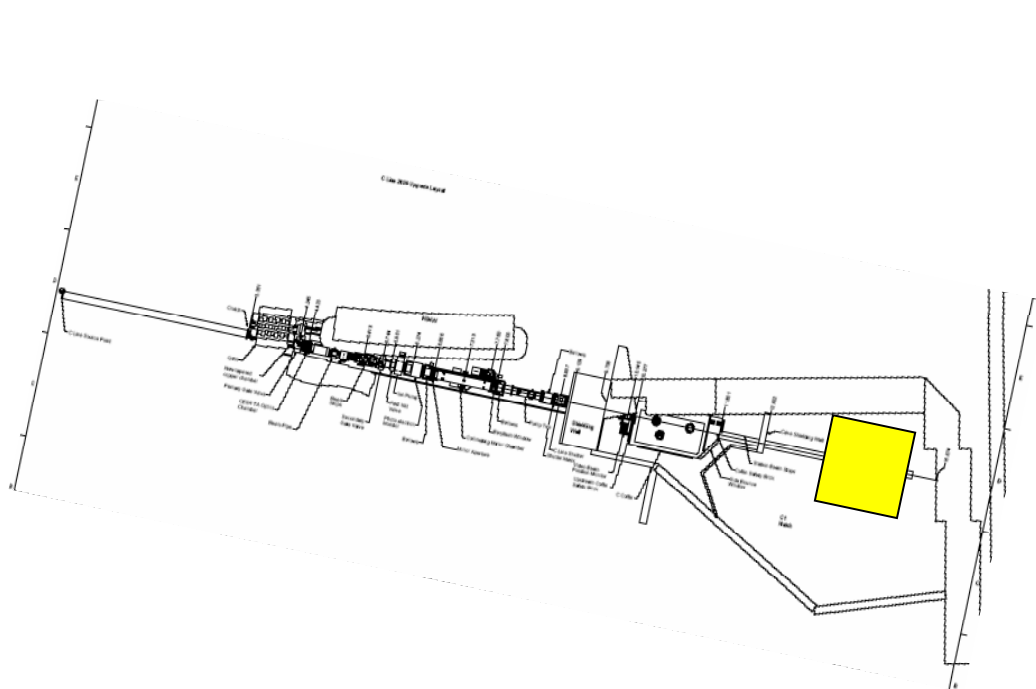

C-line, electrons

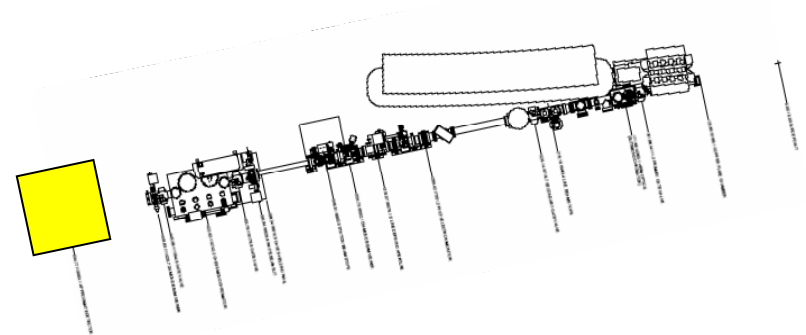

D-line, positrons

And finally, we are commissioning a second detector for the electron beam size.

Modifications for the CHESS C-line are under-way.